

True RMS Multimeter plus IR Thermometer

Extech EX470A

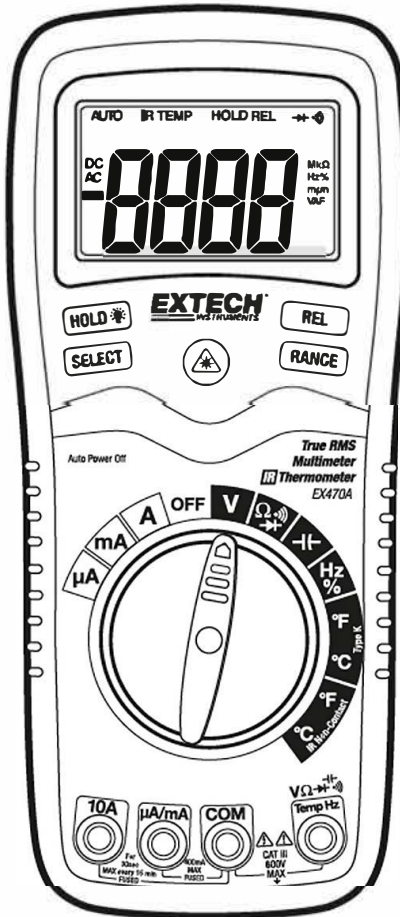

Introduction

Congratulations on your purchase of the Extech EX470A True RMS Autoranging Multimeter plus IR Thermometer. This meter measures AC/DC Voltage, AC/DC Current, Resistance, Capacitance, Frequency, Duty Cycle, Diode Test, and Continuity plus Thermocouple and Non-Contact IR Temperature. Proper use and care of this meter will provide many years of reliable service.

Safety

International Safety Symbols



This symbol, adjacent to another symbol or terminal, indicates the user must refer to the manual for further information.



This symbol, adjacent to a terminal, indicates that, under normal use, hazardous voltages may be present



Double insulation



This **WARNING** symbol indicates a potentially hazardous situation, which if not avoided, could result in death or serious injury.



This **CAUTION** symbol indicates a potentially hazardous situation, which if not avoided, may result damage to the product.



This symbol advises the user that the terminal(s) so marked must not be connected to a circuit point at which the voltage with respect to earth ground exceeds (in this case) 600 VAC or VDC.

This symbol indicates there is a potential hazard from a laser light source.



CAUTIONS

- Improper use of this meter can cause damage, shock, injury or death. Read and understand this user manual before operating the meter.
- Always remove the test leads before replacing the battery or fuses.
- Inspect the condition of the test leads and the meter itself for any damage before operating the meter. Repair or replace any damage before use.
- Use great care when making measurements if the voltages are greater than 25VAC rms or 35VDC. These voltages are considered a shock hazard.
- Warning! This is a class A equipment. This equipment can cause interference to devices in the home; in this case the operator can be required to carry out adequate measures to prevent interference.
- Always discharge capacitors and remove power from the device under test before performing Diode, Resistance or Continuity tests.
- Voltage checks on electrical outlets can be difficult and misleading because of the uncertainty of connection to the recessed electrical contacts. Other means should be used to ensure that the terminals are not "live".
- If the equipment is used in a manner not specified by the manufacturer, the protection provided by the equipment may be impaired.
- This device is not a toy and must not reach children's hands. It contains hazardous objects as well as small parts that children could swallow. In case a child swallows any of the parts, please contact a physician immediately.
- Do not leave batteries and packing material unattended; they can be dangerous for children.
- In case the device is going to be unused for an extended period of time, remove the batteries to prevent them from draining.
- Expired or damaged batteries can cause cauterization on contact with skin. Always use suitable hand protection.
- See that the batteries are not short-circuited. Do not throw batteries into fire.
- **Do not directly view or direct the laser pointer at an eye.** Low power visible lasers do not normally present a hazard, but may present some potential for hazard if viewed directly for extended periods of time



OVERVOLTAGE CATEGORY III

This meter meets the IEC 61010-1 (2010) 3rd edition standard for OVERVOLTAGE CATEGORY III. Cat III meters are protected against overvoltage transients in fixed installation at the distribution level. Examples include switches in the fixed installation and some equipment for industrial use with permanent connection to the fixed installation.

SAFETY INSTRUCTIONS

This meter has been designed for safe use, but must be operated with caution. The rules listed below must be carefully followed for safe operation.

1. **NEVER** apply voltage or current to the meter that exceeds the specified maximum:

Input Protection Limits	
Function	Maximum Input
V DC or V AC	600V, 200Vrms on 400mV range
mA AC/DC	500mA 600V fast acting fuse
A AC/DC	10A 600V fast acting fuse (30 seconds max every 15 minutes)
Frequency, Resistance, Capacitance, Duty Cycle, Diode Test, Continuity	250Vrms for 15sec max
Temperature	60V DC/24V AC

2. **USE EXTREME CAUTION** when working with high voltages.
3. **DO NOT** measure voltage if the voltage on the "COM" input jack exceeds 600V above earth ground.
4. **NEVER** connect the meter leads across a voltage source while the function switch is in the current, resistance, or diode mode. Doing so can damage the meter.
5. **ALWAYS** discharge filter capacitors in power supplies and disconnect the power when making resistance or diode tests.
6. **ALWAYS** turn off the power and disconnect the test leads before opening the covers to replace the fuse or batteries.
7. **NEVER** operate the meter unless the back cover and the battery and fuse covers are in place and fastened securely.
8. **NEVER** look directly at the laser light source or aim the pointer at an eye.



Test Equipment Depot - 800.517.8431 - 99 Washington Street Melrose, MA 02176

TestEquipmentDepot.com

Description

1. IR Thermometer and laser pointer
2. 4000 count LCD display
3. HOLD and Backlight button
4. SELECT button
5. Function switch
6. mA, uA and A input jacks
7. COM input jack
8. Positive input jack
9. RANGE hold button
10. RELATIVE button
11. Laser pointer button
12. Protective holster

Note: Tilt stand and battery compartment are on rear of unit.

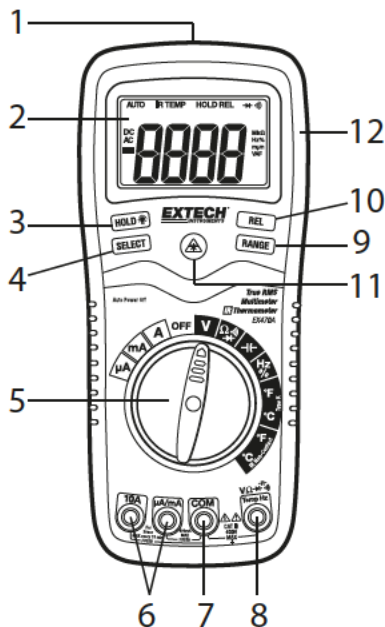

Symbols and Annunciators

•)))	Continuity		
▶	Diode test		
▲	Laser pointer		
⎓	Battery status		
✖	Test lead connection error		
n	nano (10^{-9}) (capacitance)		
μ	micro (10^{-6}) (amps, cap)		
m	milli (10^{-3}) (volts, amps)	A	Amps
k	kilo (10^3) (ohms)	F	Farads (capacitance)
M	mega (10^6) (ohms)	Ω	Ohms
Hz	Hertz (frequency)	V	Volts
%	Percent (duty ratio)	REL	Relative
AC	Alternating current	AUTO	Autorangeing
DC	Direct current	HOLD	Display hold
°F	Degrees Fahrenheit	°C	Degrees Centigrade

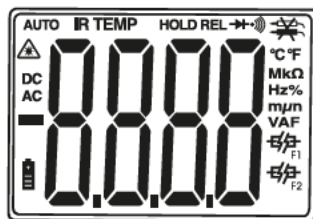

Operating Instructions

WARNING: Risk of electrocution. High-voltage circuits, both AC and DC, are very dangerous and should be measured with great care.

1. ALWAYS turn the function switch to the OFF position when the meter is not in use.
2. If "OL" appears in the display during a measurement, the value exceeds the range you have selected. Change to a higher range.

NOTE: On some low AC and DC voltage ranges, with the test leads not connected to a device, the display may show a random, changing reading. This response is normal and is caused by the high-input sensitivity. The reading will stabilize and give a proper measurement when connected to a circuit.

DC VOLTAGE MEASUREMENTS

CAUTION: Do not measure DC voltages if a motor on the circuit is being switched ON or OFF. Large voltage surges may occur that can damage the meter.

1. Set the function switch to the green V position.
2. Press the SELECT button to indicate "DC" on the display.
3. Insert the black test lead banana plug into the negative COM jack. Insert the red test lead banana plug into the positive V jack.
4. Touch the black test probe tip to the negative side of the circuit. Touch the red test probe tip to the positive side of the circuit.
5. Read the voltage in the display.



AC VOLTAGE MEASUREMENTS

WARNING: Risk of Electrocution. The probe tips may not be long enough to contact the live parts inside some 240V outlets for appliances because the contacts are recessed deep in the outlets. As a result, the reading may show 0 volts when the outlet actually has voltage on it. Make sure the probe tips are touching the metal contacts inside the outlet before assuming that no voltage is present.

CAUTION: Do not measure AC voltages if a motor on the circuit is being switched ON or OFF. Large voltage surges may occur that can damage the meter.

1. Set the function switch to the green V position.
2. Press the SELECT button to indicate "AC" on the display.
3. Insert the black test lead banana plug into the negative COM jack. Insert red test lead banana plug into the positive V jack.
4. Touch the black test probe tip to the neutral side of the circuit. Touch the red test probe tip to the "hot" side of the circuit.
5. Read the voltage in the display.

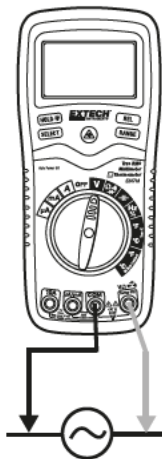

DC CURRENT MEASUREMENTS

CAUTION: Do not make current measurements on the 10A scale for longer than 30 seconds. Exceeding 30 seconds may cause damage to the meter and/or the test leads.

1. Insert the black test lead banana plug into the negative COM jack.
2. For current measurements up to $4000\mu\text{A}$ DC, set the function switch to the yellow μA position and insert the red test lead banana plug into the $\mu\text{A}/\text{mA}$ jack.
3. For current measurements up to 400mA DC, set the function switch to the yellow mA position and insert the red test lead banana plug into the $\mu\text{A}/\text{mA}$ jack.
4. For current measurements up to 10A DC, set the function switch to the yellow A range and insert the red test lead banana plug into the A jack.
5. Press the SELECT button to indicate "DC" on the display.
6. Remove power from the circuit under test, then open the circuit at the point where you wish to measure current.
7. Touch the black test probe tip to the negative side of the circuit. Touch the red test probe tip to the positive side of the circuit.
8. Apply power to the circuit.
9. Read the current in the display.

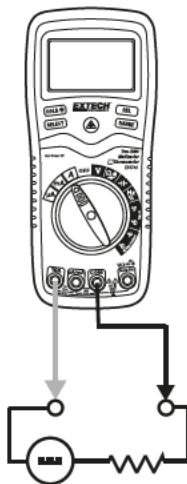

AC CURRENT MEASUREMENTS

CAUTION: Do not make current measurements on the 10A scale for longer than 30 seconds. Exceeding 30 seconds may cause damage to the meter and/or the test leads.

1. Insert the black test lead banana plug into the negative **COM** jack.
2. For current measurements up to $400\mu\text{A}$ AC, set the function switch to the yellow μA position and insert the red test lead banana plug into the $\mu\text{A}/\text{mA}$ jack.
3. For current measurements up to 400mA AC, set the function switch to the yellow **mA** position and insert the red test lead banana plug into the $\mu\text{A}/\text{mA}$ jack.
4. For current measurements up to 10A AC, set the function switch to the yellow **A** range and insert the red test lead banana plug into the **A** jack.
5. Press the **SELECT** button to indicate “**AC**” on the display.
6. Remove power from the circuit under test, then open up the circuit at the point where you wish to measure current.
7. Touch the black test probe tip to the neutral side of the circuit. Touch the red test probe tip to the “hot” side of the circuit.
8. Apply power to the circuit.
9. Read the current in the display.

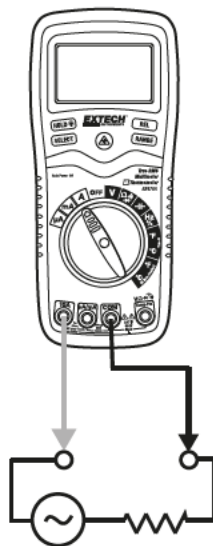

RESISTANCE MEASUREMENTS

WARNING: To avoid electric shock, disconnect power to the unit under test and discharge all capacitors before taking any resistance measurements. Remove the batteries and unplug the line cords.

1. Set the function switch to the green Ω position.
2. Insert the black test lead banana plug into the negative **COM** jack. Insert the red test lead banana plug into the positive Ω jack.
3. Press the **SELECT** button to indicate “ Ω ” on the display.
4. Touch the test probe tips across the circuit or part under test. It is best to disconnect one side of the part under test so the rest of the circuit will not interfere with the resistance reading.
5. Read the resistance in the display.

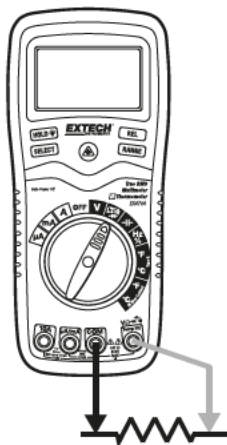

CONTINUITY CHECK

WARNING: To avoid electric shock, never measure continuity on circuits or wires that have voltage on them.

1. Set the function switch to the green $\Omega \rightarrow \rightarrow \rightarrow$ position.
2. Insert the black lead banana plug into the negative COM jack. Insert the red test lead banana plug into the positive Ω jack.
3. Press the SELECT button to indicate $\rightarrow \rightarrow \rightarrow$ and Ω on the display
4. Touch the test probe tips to the circuit or wire you wish to check.
5. If the resistance is less than approximately 150Ω , the audible signal will sound. If the circuit is open, the display will indicate "OL".

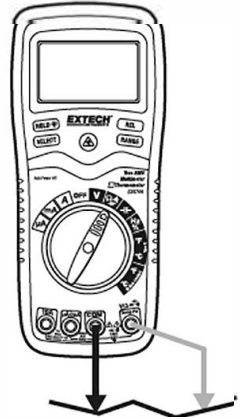

DIODE TEST

1. Set the function switch to the green $\Omega \rightarrow \rightarrow \rightarrow$ position.
2. Insert the black test lead banana plug into the negative COM jack and the red test lead banana plug into the positive V jack.
3. Press the SELECT button to indicate \rightarrow and V on the display.
4. Touch the test probes to the diode under test. Forward voltage will typically indicate 0.400 to 0.700V. Reverse voltage will indicate "OL". Shorted devices will indicate near 0V and an open device will indicate "OL" in both polarities.



CONTACT TEMPERATURE MEASUREMENTS

1. Set the function switch to the black Type K °C or °F position.
2. Insert the Temperature Probe into the input jacks, making sure to observe the correct polarity.
3. Touch the Temperature Probe head to the part whose temperature you wish to measure. Keep the probe touching the part under test until the reading stabilizes (about 30 seconds).
4. Read the temperature in the display.

Note: The temperature probe is fitted with a type K mini connector. A mini connector to banana connector adaptor is supplied for connection to the input banana jacks.



NON-CONTACT TEMPERATURE MEASUREMENTS

1. Set the function switch to the red IR Non-Contact °C or °F position.
2. Point the meter at the surface to be measured.
3. If needed, press the red IR Laser Pointer button to locate the exact spot being measured.
4. The area of the surface to be measured must be larger than the spot size as determined by the distance to spot size specification.
5. Read the temperature in the display.

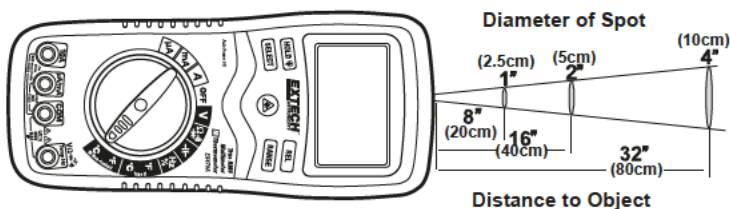

WARNING: Do not directly view or direct the laser pointer at an eye. Low power visible lasers do not normally present a hazard, but may present some potential for hazard if viewed directly for extended periods of time.



CAPACITANCE MEASUREMENTS

WARNING: To avoid electric shock, disconnect power to the unit under test and discharge all capacitors before taking any capacitance measurements. Remove the batteries and unplug the line cords.

1. Set the rotary function switch to the green F position.
2. Insert the black test lead banana plug into the negative (COM) jack. Insert the red test lead banana plug into the positive F jack.
3. Touch the test leads to the capacitor to be tested.
4. Read the capacitance value in the display

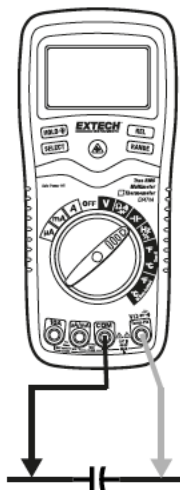

FREQUENCY MEASUREMENTS

1. Set the rotary function switch to the green "Hz" position.
2. Insert the black lead banana plug into the negative COM jack and the red test lead banana plug into the positive Hz jack.
3. Touch the test probe tips to the circuit under test.
4. Read the frequency on the display.

% DUTY CYCLE

1. Set the rotary function switch to the "Hz" position.
2. Insert the black lead banana plug into the negative COM jack and the red test lead banana plug into the positive Hz jack.
3. Press the SELECT key momentarily to select "%" in the display.
4. Touch the test probe tips to the circuit under test.
5. Read the % duty cycle on the display.

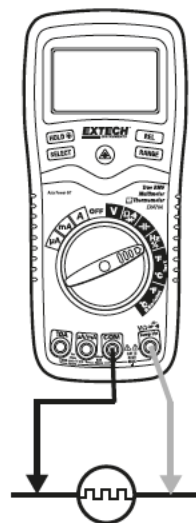

AUTORANGING/MANUAL RANGE SELECTION

When the meter is first turned on, it automatically goes into AutoRanging. This automatically selects the best range for the measurements being made and is generally the best mode for most measurements. For measurement situations requiring that a range be manually selected, perform the following:

1. Press the RANGE key. The "AUTO" display indicator will turn off.
2. Press the RANGE key to step through the available ranges until you select the range you want.
3. To exit the Manual Ranging mode and return to AutoRanging, press and hold the RANGE key for 2 seconds.

Note: Manual ranging does not apply for the Capacitance, Frequency and Temperature functions.

RELATIVE MODE

The relative measurement feature allows you to make measurements relative to a stored reference value. A reference voltage, current, etc. can be stored and measurements made in comparison to that value. The displayed value is the difference between the reference value and the measured value.

1. Perform the measurement as described in the operating instructions.
2. Press the REL button to store the reading in the display and the "REL" indicator will appear on the display.
3. The display will now indicate the difference between the stored value and the measured value.
4. Press the REL button to exit the relative mode.

Note: The Relative function does not operate in the Frequency function.

DISPLAY BACKLIGHT

Press and hold the HOLD key for >1 second to turn on or off the display backlight function.

Note: The HOLD feature will activate when the Backlight is turned on. Press the HOLD key again to exit Hold.

HOLD

The hold function freezes the reading in the display. Press the HOLD key momentarily to activate or to exit the HOLD function.

AUTO POWER OFF

The auto off feature will turn the meter off after 15 minutes.

LOW BATTERY INDICATION

The  icon will appear in the lower left corner of the display when the battery voltage becomes low. Replace the battery when this appears.

WRONG CONNECTION INDICATION

The  icon will appear in the upper right corner of the display and the buzzer will sound whenever the positive test lead is inserted into the 10A or uA/mA input jack and a non-current (green, black or red) function is selected. If this occurs, turn the meter off and reinsert the test lead into the proper input jack for the function selected.

Specifications

Function	Range	Resolution	Accuracy	
DC Voltage	400mV	0.1mV	$\pm(0.3\% \text{ reading} + 2 \text{ digits})$	
	4V	0.001V	$\pm(0.5\% \text{ reading} + 2 \text{ digits})$	
	40V	0.01V		
	400V	0.1V		
	600V	1V	$\pm(0.8\% \text{ reading} + 3 \text{ digits})$	
AC Voltage			50 to 400Hz	400Hz to 1kHz
	400mV	0.1mV	$\pm(1.5\% \text{ reading} + 15 \text{ digits})$	$\pm(2.5\% \text{ reading} + 15 \text{ digits})$
	4V	0.001V	$\pm(1.5\% \text{ reading} + 6 \text{ digits})$	$\pm(2.5\% \text{ reading} + 8 \text{ digits})$
	40V	0.01V		
	400V	0.1V		
	600V	1V	$\pm(1.8\% \text{ reading} + 6 \text{ digits})$	$\pm(3\% \text{ reading} + 8 \text{ digits})$
DC Current	400 μ A	0.1 μ A	$\pm(1.5\% \text{ reading} + 3 \text{ digits})$	
	4000 μ A	1 μ A		
	40mA	0.01mA		
	400mA	0.1mA		
	4A	0.001A	$\pm(2.5\% \text{ reading} + 5 \text{ digits})$	
	10A	0.01A		
AC Current			50 to 400Hz	400Hz to 1KHz
	400 μ A	0.1 μ A	$\pm(1.8\% \text{ reading} + 8 \text{ digits})$	$\pm(3.0\% \text{ reading} + 7 \text{ digits})$
	4000 μ A	1 μ A		
	40mA	0.01mA		
	400mA	0.1mA	$\pm(3.0\% \text{ reading} + 8 \text{ digits})$	$\pm(3.5\% \text{ reading} + 10 \text{ digits})$
	4A	0.001A		
10A	0.01A			
Resistance	400 Ω	0.1 Ω	$\pm(0.8\% \text{ reading} + 4 \text{ digits})$	
	4k Ω	0.001k Ω	$\pm(0.8\% \text{ reading} + 2 \text{ digits})$	
	40k Ω	0.01k Ω	$\pm(1.0\% \text{ reading} + 2 \text{ digits})$	
	400k Ω	0.1k Ω		
	4M Ω	0.001M Ω	$\pm(3.0\% \text{ reading} + 5 \text{ digits})$	
	40M Ω	0.01M Ω		
Capacitance	40nF	0.01nF	$\pm(5.0\% \text{ reading} + 7 \text{ digits})$	
	400nF	0.1nF	$\pm(3.0\% \text{ reading} + 5 \text{ digits})$	
	4 μ F	0.001 μ F	$\pm(3.5\% \text{ reading} + 5 \text{ digits})$	
	40 μ F	0.01 μ F		
	100 μ F	0.1 μ F	$\pm(5.0\% \text{ reading} + 5 \text{ digits})$	
Temp (type-K)	-20 to 750 C	1 C	$\pm(3.0\% \text{ reading} + 3 \text{ digits})$	
	-4 to 1382 F	1 F	(probe accuracy not included)	
Temp (IR)	-50 to 270 C	1 C	$\pm 2.0\% \text{ reading or } \pm 2 \text{ C, } \pm 4 \text{ F}$	
	-58 to 518 F	1 F		

NOTE: Accuracy is stated at 18°C to 28°C (65°F to 83°F) and less than 75% RH.

Function	Range	Resolution	Accuracy
Frequency	5.000Hz	0.001Hz	±(1.5% reading + 5 digits)
	50.00Hz	0.01Hz	
	500.0Hz	0.1Hz	
	5.000kHz	0.001kHz	±(1.2% reading + 2 digits)
	50.00kHz	0.01kHz	
	500.0kHz	0.1kHz	
	5.000MHz	0.001MHz	±(1.5% reading + 4 digits)
	10.00MHz	0.01MHz	
Sensitivity: 0.8V rms min. @ 20% to 80% duty cycle and <100kHz; 5Vrms min @ 20% to 80% duty cycle and > 100kHz.			
Duty Cycle	0.1 to 99.9%	0.1%	±(1.2% reading + 2 digits)
	Pulse width: 100µs - 100ms, Frequency: 5Hz to 150kHz		

Note: Accuracy specifications consist of two elements:

- (% reading) – This is the accuracy of the measurement circuit.
- (+ digits) – This is the accuracy of the analog to digital converter.

Diode Test	Test current of 0.3mA maximum, open circuit voltage 1.5V DC typical
Continuity Check	Audible signal will sound if the resistance is less than 150Ω (approx.), test current <0.7mA
Temperature Sensor	Requires Type-K thermocouple
IR Spectral response	6 to 16µm
IR Emissivity	0.95 fixed
IR distance ratio	8:1
Input Impedance	>7.5MΩ (VDC & VAC)
AC Response	True rms
ACV Bandwidth	50Hz to 1kHz
Crest Factor	<3:1 at full scale & <6:1 at half scale
Display	4000 count backlit liquid crystal
Overrange indication	“OL” is displayed
Auto Power Off	15 minutes (approximately)
Polarity	Automatic (no indication for positive); Minus (-) sign for negative
Measurement Rate	2 times per second, nominal
Low Battery Indication	“  ” is displayed if battery voltage drops below operating voltage
Battery	One 9 volt (NEDA 1604) battery
Fuses	mA, µA ranges; 0.5A/600V fast blow A range; 10A/600V ceramic fast blow
Operating Temperature	5°C to 40°C (41°F to 104°F)
Storage Temperature	-20°C to 60°C (-4°F to 140°F)
Operating Humidity	Max 80% up to 31°C (87°F) decreasing linearly to 50% at 40°C (104°F)
Storage Humidity	<80%
Operating Altitude	2000 meters (7000ft) maximum.
Weight	342g (0.753lb) (includes holster).
Size	187 x 81 x 50mm (7.36” x 3.2” x 2.0”) (includes holster)
Safety	For indoor use and in accordance with the requirements for double insulation to: EN61010-1 (2010) 3rd edition Overvoltage Category III 600V; Pollution Degree 2.
Patent Notice	U.S. Patent 7056012

Maintenance

WARNING: To avoid electrical shock, disconnect the meter from any circuit, remove the test leads from the input terminals, and turn OFF the meter before opening the case. Do not operate the meter with an open case.

This MultiMeter is designed to provide years of dependable service, if the following care instructions are performed:

1. **KEEP THE METER DRY.** If it gets wet, wipe it off.
2. **USE AND STORE THE METER IN NORMAL TEMPERATURES.** Temperature extremes can shorten the life of the electronic parts and distort or melt plastic parts.
3. **HANDLE THE METER GENTLY AND CAREFULLY.** Dropping it can damage the electronic parts or the case.
4. **KEEP THE METER CLEAN.** Wipe the case occasionally with a damp cloth. DO NOT use chemicals, cleaning solvents, or detergents.
5. **USE ONLY FRESH BATTERIES OF THE RECOMMENDED SIZE AND TYPE.** Remove old or weak batteries so they do not leak and damage the unit.
6. **IF THE METER IS TO BE STORED FOR A LONG PERIOD OF TIME,** the batteries should be removed to prevent damage to the unit.

Battery Replacement

1. Remove the Phillips head screw that secures the rear battery door
2. Open the battery compartment
3. Replace the 9V battery
4. Secure the battery compartment



Never dispose of used batteries or rechargeable batteries in household waste. As consumers, users are legally required to take used batteries to appropriate collection sites, the retail store where the batteries were purchased, or wherever batteries are sold.

Disposal: Do not dispose of this instrument in household waste. The user is obligated to take end-of-life devices to a designated collection point for the disposal of electrical and electronic equipment.

Other Battery Safety Reminders

- Never dispose of batteries in a fire. Batteries may explode or leak.
- Never mix battery types. Always install new batteries of the same type.

WARNING: To avoid electric shock, do not operate the meter until the battery cover is in place and fastened securely.

NOTE: If your meter does not work properly, check the fuses and batteries to make sure that they are still good and that they are properly inserted.

REPLACING THE FUSES

WARNING: To avoid electrical shock, disconnect the meter from any circuit, remove the test leads from the input terminals, and turn OFF the meter before opening the case. Do not operate the meter with an open case.

1. Disconnect the test leads from the meter.
2. Remove the protective rubber holster.
3. Remove the battery cover (two "B" screws) and the battery.
4. Remove the four "A" screws securing the rear cover.
5. Lift the center circuit board straight up from the connectors to gain access to the fuse holders.
6. Gently remove the old fuse and install the new fuse into the holder.
7. Always use a fuse of the proper size and value (0.5A/600V fast blow for the 400mA range, 10A/600V fast blow for the 10A range).
8. Align the center board with the connectors and gently press into place.
9. Replace and secure the rear cover, battery and battery cover.

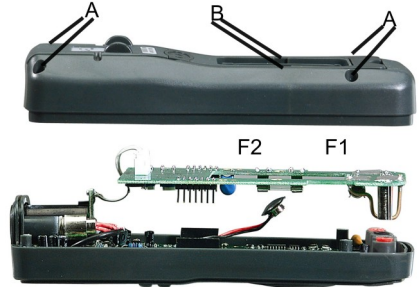

WARNING: To avoid electric shock, do not operate your meter until the fuse cover is in place and fastened securely.

Test Equipment Depot - 800.517.8431 - 99 Washington Street Melrose, MA 02176

TestEquipmentDepot.com