

# Model CW120 Clamp-on Power Meter

Maintenance and long term monitoring of electrical equipment and electrical system.

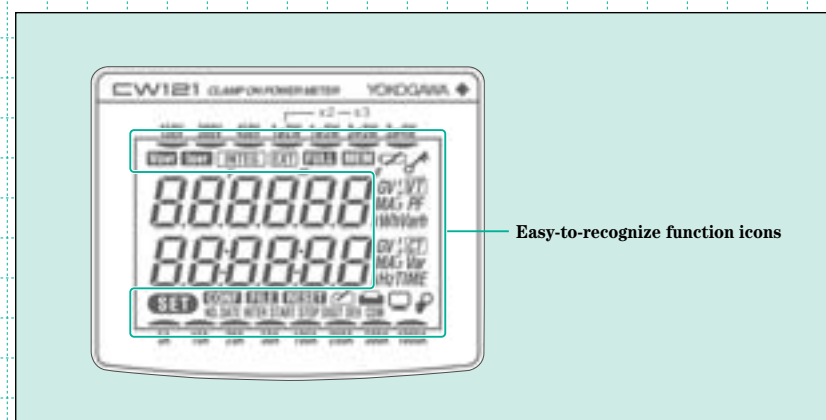

## Model CW121-□-1



## Low-cost tools to support your energy conservation efforts

As energy conservation becomes increasingly important, we are pleased to present low-cost clamp-on power meters designed to meet user needs for simple tools capable of measuring power values and instantaneous values.

### Useful features for energy conservation and power measurement

- Periodically save data as often as once a second**  
 Data can be saved as low as 1-second interval. This capability allows the CW120 Series to respond quickly to load fluctuations and measure transient responses in equipment.
- Check equipment operating conditions**  
 The CW120 Series has an instantaneous value filing function (enabling multiple data records to be saved in a single file when multiple measurements are taken) which is useful for determining equipment operating conditions.
- Wiring error check function**  
 This function helps ensure that measurement operations are correct.
- Simultaneous measurement of multiple facilities**  
 Multiple CW120 Series units can start and stop integration simultaneously through externally controlled I/O.
- Works even with small electric energy values**  
 Easily change the decimal position (the number of digits following the decimal point) and display unit (Wh, kWh, MWh, GWh) on the electric energy display.

### Details for Models CW120/CW121

| Items            | CW120/CW121                                  |   |
|------------------|--|---|
| Measurement Mode | Input system                                 | Single-phase 2-wire to 3-phase 4-wire       |
|                  | Instant mode                                 | (Up to 3 phase 3 wire for CW120)            |
| Display          | Screen                                       | Segmented LCD with backlight                |
|                  | Electric Energy mode                         | Available                                   |
| Communication    | Interface                                    | RS232 or RS485                              |
|                  | Protocol                                     | MODBUS, PC-link, Power-Monitor, Proprietary |
|                  | Monitoring by AP240E                         | Available                                   |
| Power supply     | 100 to 240V AC, Supply the power from input. |   |
| Size (W×H×D)     | 117×161×51mm                                 |   |
| Weight           | 600g   |   |

### Load measurements on multiple systems

- In addition to support for a variety of connection types, The CW120 Series can simultaneously measure the loads\* (facilities, equipment) on multiple systems sharing a common power supply.  
 CW120 (three-phase 3-wire model): 1ø2W×2  
 CW121 (three-phase 4-wire model): 1ø2W×2, ×3

1ø2W Three current systems (example)

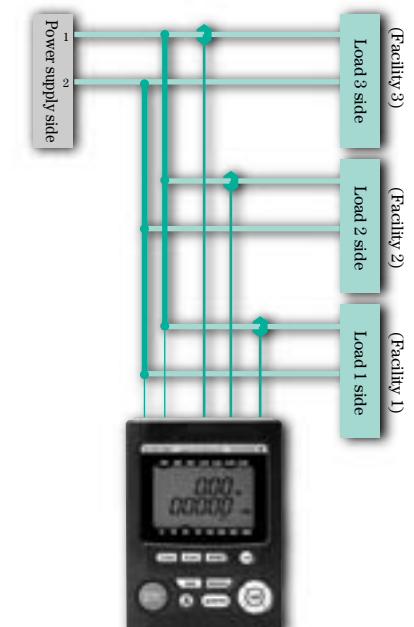

## Low-cost tools to support your energy conservation efforts

### Compact design

- The CW120 Series is compact in size (117×161×51mm (W×H×D)), making it ideal for installation in cubicles and inside distribution panels. Installation is even easier with the magnetic case (93023).
- Although the CW120 Series is small, it has a large backlit LCD.
- A new addition to the clamp lineup is a small-diameter current clamp (model 96033, capable of measurements in the range of 5–50 A) for measurements in tight spots and locations where many wires are jumbled together.

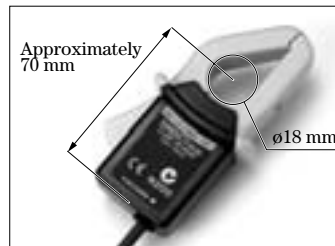

Current clamp (96033)



Magnetic case (93023)

### Measurements

- The CW120 Series can be used for voltage measurements up to 495 V.
- A variety of connection types are supported, from single-phase 2-wire to three-phase 4-wire (CW120: three-phase 3-wire model; CW121: three-phase 4-wire model).
- Continuous measurement integration (accurate measurements can be obtained even if there are large load fluctuations)
- Plus/minus signs are shown for reactive power and power factor.
- The data saving interval can be set in the range of one second to one hour.

### Parameters setting tool (name: Toolbox)

The setting software allows you to set CW120 Series measurement conditions through a PC and save measurement data on a PC when the unit is connected to the PC through RS-232 or RS-485 port.

#### ● Measurement conditions setting function

This function makes it easy to set basic functions needed for measurement, such as start/stop time and date, wiring method, clamp type, voltage, and current range etc.

#### ● File transfer function

The data file stored in CF pack can be transferred to PC. Microsoft Excel can read transferred data file.

\* Toolbox is included as a standard feature (on two floppy disks).

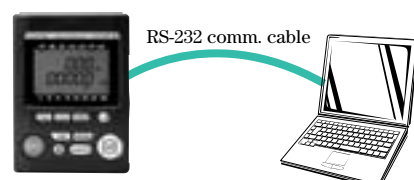

Microsoft, Windows, and Excel are trademarks or registered trademarks of Microsoft Corporation, the United States.



Setting screen



File transfer screen

## Advanced data management and communication

### Data management and communication

- ① You can connect CW120 to a PC through dedicated RS-232 cable.
- ② A printer (sold separately) can be connected through RS-232 cable to print measurement data.
- ③ If you have a media reader connected to your PC or card slot in notebook PC, measurement data and settings can be uploaded directly to a PC from CF\* pack.

| Wiring Method | Memory | Interval Time | Stored Period    |
|---------------|--------|---------------|------------------|
| 3φ4W          | 16MB   | 1 Second      | Approx 24 Hours  |
| 3φ4W          | 16MB   | 1 Minute      | Approx 2 Months  |
| 3φ4W          | 16MB   | 10 Minutes    | More than 1 Year |
| 3φ4W          | 32MB   | 1 Second      | Approx 40 Hours  |
| 3φ4W          | 32MB   | 10 Minutes    | Approx 4 Months  |

\* Compact Flash cards with memory capacity up to 128 MB may be used (recommended brand: SanDisk).

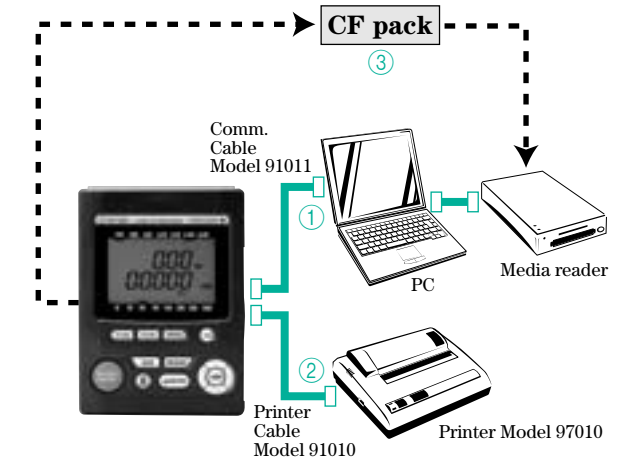

### Network Communication

CW120 In addition to proprietary communication also supports, MODBUS, PC-link and Power Monitor protocols. PC-link is a protocol for Yokogawa's Temperature controllers and PLCs. Power Monitor protocol is a protocol for Yokogawa's Power Monitors. (PR201)

#### Data Management by DAQLOGGER\*

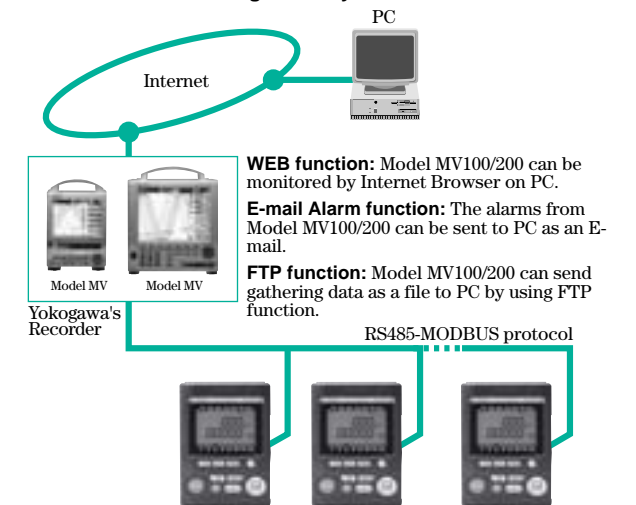

\* DAQLOGGER is Yokogawa's communication software for Windows 95/98/NT4.0/2000/XP

### Remote monitoring

The RS-485 allows multiple use to be connected for remote monitoring.

\* RS-485/RS-232 converter is required to connect the CW120/CW121-m-2 (RS-485 communication spec) to the RS-232 port on your PC. Recommended brand and model: Yokogawa's RS-232/RS-485 Converter Model ML1.

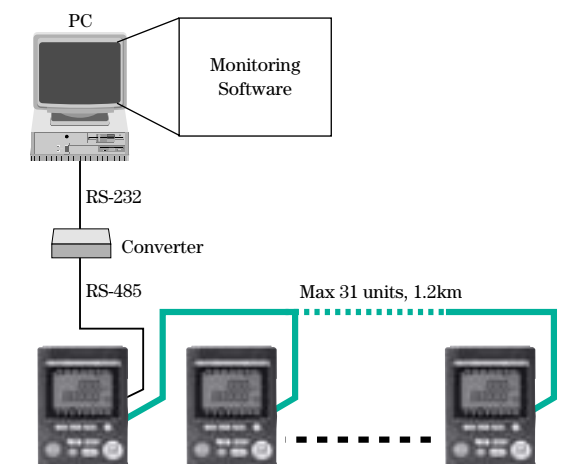

## Inputs

| Parameter             | Voltage (V)  | Current (A)   |
|-----------------------|--|---|
| Input type            | Resistive potential division   | Clamp detection   |
| Rated value (range)   | 150/300/450 V  | Clamp 96033: 5/10/20/50 A<br>Clamp 96030: 20/50/100/200 A<br>Clamp 96031: 50/100/200/500 A<br>Clamp 96032: 200/500/1000 A |
| Wiring                | CW120: Single-phase 2-wire, single-phase 3-wire, three-phase 3-wire<br>CW121: Single-phase 2-wire, single-phase 3-wire, three-phase 3-wire, three-phase 4-wire |   |
| Input resistance      | CW120: Approximately 1.5 MΩ<br>CW121: Approximately 1.3 MΩ   | Approximately 100 kΩ  |
| Maximum allowed input | 495 Vrms   | Clamp 96033: 130 Arms<br>Clamp 96030: 250 Arms<br>Clamp 96031: 625 Arms<br>Clamp 96032: 1000 Arms                         |
| A/D converter         | Voltage/current input simultaneous conversion, 12-bit resolution   |   |

## Measurement Input functions

| Parameter                 | Voltage  | Current/active power                            |
|---------------------------|--|---|
| Method                    | Digital sampling                               |   |
| Frequency range           | 45–65 Hz (reciprocal system), detected from V1 |   |
| Crest factor              | 150/300 V range                                | Rated input: 2                                  |
|                           | 450 V range                                    | Rated input: 1.56                               |
| Active input range        | 10–110% of each range                          |   |
| Display range             | Lower limit                                    | All ranges 1.5 V                                |
|                           | Upper limit                                    | 130% of each range, except 110% for 450 V range |
| Temperature coefficient   | ±0.05% mg/C                                    |   |
| Display updating interval | Approximately one second                       |   |

## Instantaneous Value Measurement

- Measurement parameters: Voltage rms (V), current rms (A), active power (W), frequency (Hz)
- Measurement accuracy (at power factor 1, including clamp):
  - Voltage: ±(0.3% rdg + 0.2% rng)
  - Current/active power: ±(0.8% rdg + 0.4% rng) when using clamps 96030, 96031, and 96033
  - ±(1.2% rdg + 0.8% rng) when using clamp 96032
  - ±(0.1% rdg + 1% dgt)
- Computation parameters: Reactive power (Var), power factor (value calculated from measurement) ±1 dgt
- Computation accuracy: ±1.0% mg cosφ = ±0.5 (relative to power factor 1) when using clamp 96030
- Power factor influence: ±2.0% mg cosφ = ±0.5 (relative to power factor 1) when using clamps 96031, 96032, and 96033
- Reactive factor influence: ±1.0% mg sinφ = ±0.5 (relative to reactive factor 1) when using clamp 96030
- ±2.0% mg sinφ = ±0.5 (relative to reactive factor 1) when using clamps 96031, 96032, and 96033

## Equations

- Voltage rms:  $V_{rms} = \sqrt{\frac{1}{T} \int_0^T v(t)^2 dt} = \sqrt{\frac{1}{T} \sum_{i=1}^n v_i(t)^2}$
- Current rms:  $I_{rms} = \sqrt{\frac{1}{T} \int_0^T i(t)^2 dt} = \sqrt{\frac{1}{T} \sum_{i=1}^n i_i(t)^2}$
- Active power:  $P = \frac{1}{T} \int_0^T v(t) \times i(t) dt = \frac{1}{T} \sum_{i=1}^n v_i(t) \times i_i(t)$   
 Single-phase 3-wire, three-phase 3-wire:  $\sum P = P1 + P2$   
 Three-phase 4-wire:  $\sum P = P1 + P2 + P3$   
 v(t), i(t): Input signals  
 T: One period for input signal

|                             | Reactive power (Note 2)  | Apparent power   | Power factor (Note 2)  |
|-----------------------------|--|--|------------------------|
| Single-phase 2-wire         | $Q_i = \sqrt{(VA_i)^2 - P_i^2}$  | $VA = V \times A$  | $P/VA$                 |
| Single-phase 3-wire         | $Q_i = \sqrt{(VA_i)^2 - P_i^2}$ i=1, 2<br>$\Sigma Q = Q1 + Q2$         | $VA_i = V_i \times A_i$ i=1, 2<br>$\Sigma VA = VA1 + VA2$              |                        |
| Three-phase 3-wire (Note 3) | $Q_i = \sqrt{(VA_i)^2 - P_i^2}$ i=1, 2<br>$\Sigma Q = Q1 + Q2$         | $VA_i = V_i \times A_i$ i=1, 2<br>$\Sigma VA = \sqrt{3}/2 (VA1 + VA2)$ | $\Sigma P / \Sigma VA$ |
| Three-phase 4-wire          | $Q_i = \sqrt{(VA_i)^2 - P_i^2}$ i=1, 2, 3<br>$\Sigma Q = Q1 + Q2 + Q3$ | $VA_i = V_i \times A_i$ i=1, 2, 3<br>$\Sigma VA = VA1 + VA2 + VA3$     |                        |
| Computation range           | Rated value depends on V and A ranges.                                 |  | -1 ~ +1                |
| Display resolution          | Same as for active power.  |  | ±1.000                 |

- Note 1: In the case of distorted waves, there may be differences from other measuring instruments that are based on different measurement principles.
- Note 2: The polarity of each phase determined by the reactive power meter method is multiplied and the polarity is displayed.
- Note 3: In the case of three-phase 3-wire and unbalanced inputs, there may be differences from other measuring instruments that are based on different measurement principles, or wiring.

## Electric Energy Measurement

- Measured parameters: Active electric energy, regenerative electric energy (regenerative electric energy is not displayed on the screen; it is merely saved)
- Measurement accuracy: Active power measurement accuracy ±1 dgt (with standard settings)
- Integration function settings: Start/stop settings: Manual, timer, external trigger (control)
- Output intervals: 1/2/5/10/15/30 seconds; 1/2/5/10/15/30 minutes; 1 hour
- Displayed digits: This is set automatically based on the rated power, and the minimum resolution can be set

## Saving items

- Saving items: Voltage, current, active power, reactive power, power factor, frequency, active electric energy, regenerative electric energy

## Display Functions

- Display screen: Backlit segmented LCD
- Maximum number of displayed digits:
  - Electric energy: 6 digits
  - Other parameters: 4 digits
- Range makeup: (rated values)

## Communication Functions

- Electrical specifications: Conforms to EIA RS-232 or EIA RS-485.
- Protocols: CW120/121 proprietary protocol, Power Monitor protocol (Standard protocol used for YOKOGAWA M&C's Power Monitor)  
PC link communication (Standard protocol used for YOKOGAWA M&C's Temperature Controllers)  
MODBUS communication (ASCII or RTU)
- Synchronization system: Start stop synchronization
- Baud rates: 1200, 2400, 4800, 9600, 19200, 38400 bps

## PC card interface

- Slot: PC card slot TYPE II
- Compatible card: ATA flash memory card
- Function specifications: Saving measurement data, saving and reading settings data

## Faulty Wiring Checking Functions

- Check details: Presence/absence of power input; check for frequency measurement range; voltage phase sequence; presence/absence of power input; whether current clamp is reverse-connected

## Scaling Function

- The VT ratio and CT ratio can be set.
- Settings ranges: VT ratio: 1–10,000  
CT ratio: 1–10,000 (in increments of 0.01)

## External Control I/O (for RS-232 only; not provided for RS-485)

- These input and output can be used as signals for starting and stopping integrating measurement.
- Control input: TTL level or contact
- Control output: TTL level

## Other Functions

- Clock (typical precision: ±100 ppm), key lock, system reset

## General Specifications

- Environmental requirements: Indoor usage at an altitude of 2000 meters or less.
- Usage temperature and humidity ranges: 0–50°C, 5–85% RH (no condensation)  
0–40°C, 5–85% RH (no condensation) for UL, C-UL
- Storage temperature and humidity ranges: -20–60°C, 90% RH (no condensation)
- Insulating resistance: 500 V DC, 50 MW or greater
- Between voltage input terminals and case
- Between voltage input terminals and current input terminals, communication terminals, and control I/O terminals
- Between power line and case
- Between power line and current input terminals, communication terminals, and control I/O terminals
- Insulating withstand voltage: 5550 V AC for one minute  
Between voltage input terminals and case  
3320 V AC for one minute  
Between voltage input terminals and current input terminals, communication terminals, and control I/O terminals  
2300 V AC for one minute  
Between power line and case  
Between power line and current input terminals, communication terminals, and control I/O terminals
- Power supply: 100–240 V AC ±10%, 50/60 Hz
- Consumed power: 8 VA maximum
- External magnetic field effects: Within accuracy levels at 400 A/m
- External dimensions: Approximately 117 × 161 × 51 mm (W × H × D)
- Weight: Approximately 0.6 kg
- Terminals: Voltage input: CW120: 3 terminals Banana terminals (safety terminals)  
CW121: 4 terminals Banana terminals (safety terminals)  
Current terminals: CW120: 2 pairs Banana terminals (safety terminals)  
(H/L) CW121: 3 pairs Banana terminals (safety terminals)  
External control I/O: 3 terminals (H/L/H) Screwless terminals  
terminals RS-485: 4 terminals (+/-/SG/TM) M3 screw terminals
- Connectors: RS-232: Mini DIN 8-pin  
AC power supply: 2-pin
- Accessories: Voltage input probes: 3 for CW120, 4 for CW121  
Power cord, user's manual, operation guide, Toolbox (setting software)
- Safety standards: Compliant with EN61010-1, EN61010-2-031, UL3111-1 First Edition, CAN C22.2 No. 1010.1-92  
– Voltage input line  
Measurement (Overvoltage) category III (Max. input voltage : 600 Vrms)  
– Power line  
Installation category II (Max. input voltage : 264 Vrms)  
Pollution degree 2
- EMC (emission): Compliant with EN55011, Group1, ClassA; EN61326; EN61000-3-2; EN61000-3-3
- EMC (immunity): Compliant with EN61326

| Voltage | Wiring | Clamp 96032 |          |          |          |             |          |          |          |
|---------|--------|-------------|----------|----------|----------|-------------|----------|----------|----------|
|         |        | Clamp 96031 |          |          |          | Clamp 96030 |          |          |          |
|         |        | Clamp 96033 |          |          |          |             |          |          |          |
|         |        | 5.000 A     | 10.00 A  | 20.00 A  | 50.00 A  | 100.0 A     | 200.0 A  | 500.0 A  | 1.000 kA |
| 150.0V  | 1φ2W   | 750.0 W     | 1.500 kW | 3.000 kW | 7.500 kW | 15.00 kW    | 30.00 kW | 75.00 kW | 150.0 kW |
|         | 1φ3W   | 1.500 kW    | 3.000 kW | 6.000 kW | 15.00 kW | 30.00 kW    | 60.00 kW | 150.0 kW | 300.0 kW |
|         | 3φ3W   | 1.500 kW    | 3.000 kW | 6.000 kW | 15.00 kW | 30.00 kW    | 60.00 kW | 150.0 kW | 300.0 kW |
|         | 3φ4W   | 2.250 kW    | 4.500 kW | 9.000 kW | 22.50 kW | 45.00 kW    | 90.00 kW | 225.0 kW | 450.0 kW |
| 300.0V  | 1φ2W   | 1.500 kW    | 3.000 kW | 6.000 kW | 15.00 kW | 30.00 kW    | 60.00 kW | 150.0 kW | 300.0 kW |
|         | 1φ3W   | 3.000 kW    | 6.000 kW | 12.00 kW | 30.00 kW | 60.00 kW    | 120.0 kW | 300.0 kW | 600.0 kW |
|         | 3φ3W   | 3.000 kW    | 6.000 kW | 12.00 kW | 30.00 kW | 60.00 kW    | 120.0 kW | 300.0 kW | 600.0 kW |
|         | 3φ4W   | 4.500 kW    | 9.000 kW | 18.00 kW | 45.00 kW | 90.00 kW    | 180.0 kW | 450.0 kW | 900.0 kW |
| 450.0V  | 1φ2W   | 2.250 kW    | 4.500 kW | 9.000 kW | 22.50 kW | 45.00 kW    | 90.00 kW | 225.0 kW | 450.0 kW |
|         | 1φ3W   | 4.500 kW    | 9.000 kW | 18.00 kW | 45.00 kW | 90.00 kW    | 180.0 kW | 450.0 kW | 900.0 kW |
|         | 3φ3W   | 4.500 kW    | 9.000 kW | 18.00 kW | 45.00 kW | 90.00 kW    | 180.0 kW | 450.0 kW | 900.0 kW |
|         | 3φ4W   | 6.750 kW    | 13.50 kW | 27.00 kW | 67.50 kW | 135.0 kW    | 270.0 kW | 675.0 kW | 1.350 MW |