

Safety precautions

Various symbols are used on the instrument and throughout this manual to ensure safe use of the product and to protect against possible hazards or damage. The following safety symbols are used where appropriate. Read the explanations carefully and familiarize yourself with the symbols before reading the text.

WARNING This symbol indicates that misuse of the instrument could result in injury or death of personnel.

CAUTION This symbol indicates that misuse of the instrument could result in injury of personnel or damage to the instrument.

The following safety symbols are used on the instrument and in this manual:

Caution
This symbol indicates that the operator must refer to an explanation in the instruction manual in order to avoid the risk of injury or death of personnel or damage to the instrument.

Double Insulation
This symbol indicates double insulation.



Alternating Current
This symbol indicates AC voltage/current.

Direct Current
This symbol indicates DC voltage/current.

Earth TERMINAL
This symbol indicates ground.

Store this manual in a safe place for future reference.

Components

- 1) Jaw Section**
Is a precision sensor for detecting currents.
- 2) Open/Close Lever**
Opens and closes the jaws.
- 3) Display**
Shows the measured value (digital reading or bar graph), unit, function and low-battery symbol ().
- 4) mA/A Selector Switch**
Selects the unit of AC current (either "mA" or "A") to be measured.
- 5) Data Hold Switch**
Retains the measured data. If you press this switch, the  symbol appears and the data is retained. If you press this switch once again, data holding is canceled (the  symbol disappears).
- 6) Power Switch**
Turns on the power to the instrument.
- 7) Battery Housing**
Contains the battery.

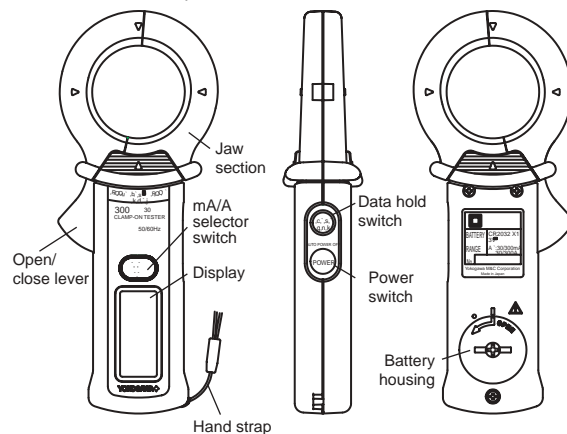

Measuring Instructions

CAUTION

- The jaw section is a delicate, precision sensor. Do not subject the jaw to unreasonably strong shock, vibration, or force when using it.
- If dust gets into the tops of the jaws, remove it immediately. Do not close the jaws when dust is trapped in its joints as the sensor may break.

AC Current Measurement (unit: mA/A)

- Press the POWER switch to turn on the power.
- Squeeze the open/close lever to open the jaws. Insert a wire from the measurable conductors under test through the jaws, making sure the tops of the jaws are tightly shut.
- When the reading stabilizes, read the value. If you have difficulties in reading the value, use the DATA HOLD function.
- When you have finished measurement, press the POWER switch to turn off the tester.

Examples of Leakage Current Measurement

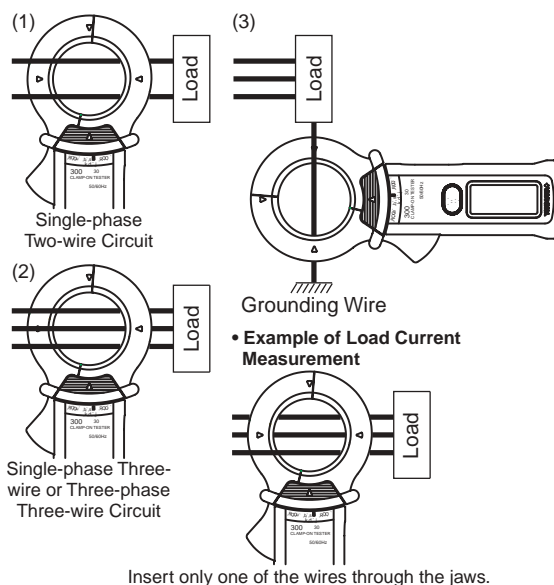

Insert only one of the wires through the jaws.

AUTO POWER OFF Function

The tester automatically turns off 10 minutes after the last switch operation. A buzzer starts to beep 15 seconds before the automatic power-off.

Battery Replacement

If the battery voltage drops below the operating voltage, the  symbol turns on. If this happens, replace the battery with a new one (CR2032 lithium battery) as soon as possible.

CAUTION

- There is a risk of electrical shock during battery replacement. always remove the tester from the measurable conductors under test before replacing the battery.
- Use a battery of the same model.

To replace the battery:

- Press the POWER switch to turn off the power.
- Turn the battery cover on the backside of the tester in the direction of the arrow using a coin or a Phillips screwdriver.
- Remove the cover and the battery.
- Insert a new battery, making sure that the polarities are correct.
- Close the cover back in place by turning it in the reverse direction of the arrow.

Inserting a Battery

Insert the battery being careful that the polarities are correct.

Closing the Battery Cover

Close the battery cover, aligning the arrow's tail with the dot and then turn clockwise.

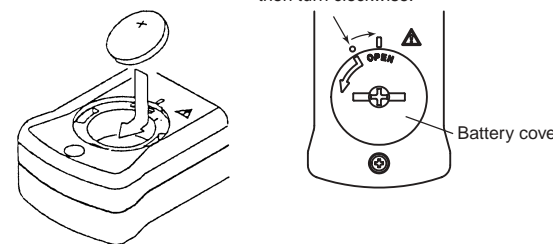

Specifications

General Specifications

- Measurement functions: AC current
- Additional functions: Data hold and Auto power-off
- Display (LCD): Digital reading 3200 counts
Bar graph 32 segments
"OL" over-range indication
 low-battery symbol
- Range selection: Automatic (Which range is within mA or A)
- Sampling: Digital reading 2 times/sec
Bar graph 12 times/sec
- Operating temperature and humidity range: 0 to 50°C, with a maximum humidity of 80% RH (no condensation)
- Storage temperature and humidity range: -20 to 60°C, with humidity range is 20 to 70% RH (no condensation)
- Temperature coefficient: Model 300 30: ±0.05% of measuring range/°C when the measuring range is 0 to 200 A over a temperature range of either 0 to 18°C or 28 to 50°C
Model 300 31: ±0.05% of measuring range/°C when the measuring range is 0 to 50 A over a temperature range of either 0 to 18°C or 28 to 50°C
- Effect of external magnetic fields: 0.01% maximum for Model 300 30 (in terms of the magnitude of current in adjacent wires)
0.0005% typical value for Model 300 31 (in terms of the magnitude of current in adjacent wires)
- Diameter of measurable conductors: 40 mm (Maximum)
- Circuit voltage limit: 300 Vrms or less
- Withstanding voltage: 3.7 kV AC for one minute (Tested between the cores of the jaw section and the case)
- Power consumption: 5mW maximum for Model 300 30
6mW maximum for Model 300 31
- Automatic power-off: Automatically turns of the power approx. 10 minutes after the last switch operation. (The alarm buzzer begins beeping 15 seconds before power-off.)
- Power supply: CR2032 lithium battery 1
- Battery life: Approx. 120 hours (of continuous operation) for Model 300 30
Approx. 90 hours (of continuous operation) for Model 300 31
- Dimensions: 70 (W) × 176 (H) × 25 (D) (mm), excluding protrusions
- Weight: Approx. 180 g for Model 300 30 (including the battery)
Approx. 200 g for Model 300 31 (including the battery)

- Safety standards: EN 61010-1; 1993 +A2; 1995
EN 61010-2-03; 1995
(AC/DC 300 V CAT.III, Pollution degree2, indoor use)
- EMC standards: EN 55011; 1998 Group 1 Class B
EN61326-1;1997+A1; 1998
- Effect of radiation immunity: Accuracy range of reading (Rated accuracy +4.0% of each range) for the strength of a radio-frequency electromagnetic field of 3v/m.
2000m or less above sea level.
- Operable altitude: 2000m or less above sea level.
- Accessories: Battery (housed in the instrument) 1
RB057 soft carrying case 1
Instruction manual 1

Electrical Specification

Test condition: 23 ±5°C and 80% RH maximum
Accuracy: ±(percent of reading + LSD reading)

AC current measurement

Model 300 30		Mean-value detection and rms-value calibration	
Range	Resolution	Accuracy (50/60 Hz)	Maximum Allowable Current
30 mA	0.01 mA	1% + 5	300 Arms
300 mA	0.1 mA		
30 A	0.01 A	0 to 200 A: 1.2% + 5	
300 A	0.1 A	200 to 300 A: 5% + 5	

Model 300 31		Mean-value detection and rms-value calibration	
Range	Resolution	Accuracy (50/60 Hz)	Maximum Allowable Current
3 mA	0.001 mA	1% + 5	60 Arms
30 mA	0.01 mA		
30 A	0.01 A	0 to 50 A: 1% + 5	
60 A	0.1 A	50 to 60 A: 5% + 5	

Zero correction: Fractions smaller than approximately 0.01 mA are calibrated to zero.

GAWA IM 30030E
M&C Corporation 1st Edition: Feb. 1999
3rd Edition: Mar. 2001
Copyright Feb. 1999(YG). 3rd Edition; Mar. 2001(YG)

Test Equipment Depot
99 Washington Street
Melrose, MA 02176
Fax 781-665-0780
TestEquipmentDepot.com
1-800-517-8431

WARNING

- To avoid electric shock!**
Do not use the instrument if there is any damage to the casing or when the casing is removed.
- Disconnect the instrument from the measurable conductors under test before opening the casing to replace the battery.
- Avoid using the instrument if it has been exposed to rain or moisture or if your hands are wet.
- To avoid electric shock or fire!**
Do not use the instrument in an atmosphere where any flammable or explosive gas is present.

WARNING

- To avoid damage to the instrument or electric shock!**
The restrictions on the maximum voltage level for which the 300 30 and 300 31 testers can be used, depend on the over-voltage categories specified by the safety standards. These category specifications are formulated to protect operators against transient impulse voltages in power lines.

Model	Over-voltage category (CAT.)	Maximum Allowable Input
300 30	III	300 Arms (Voltage of circuit under test: 300 Vrms AC)
300 31	III	60 Arms (Voltage of circuit under test: 300 Vrms AC)

Over-voltage category I (CAT.I):
Signal level, special equipment or parts of equipment, telecommunication, electronic etc., with smaller transient over-voltages than CAT.II.

Over-voltage category II (CAT.II):
Local level, appliances, portable equipment etc., with smaller transient over-voltages than CAT.III.

Over-voltage category III (CAT.III):
Distribution level, fixed installation, with smaller transient over-voltages than CAT.IV.

CAUTION

- Do not use the instrument near noise-emitting equipment or where there may be sudden changes in temperature. Otherwise, the instrument may produce an unstable readings or errors.
- Do not wipe the instrument using an organic solvent such as benzene or paint thinner. Otherwise, the front panel may be damaged or discolored. When cleaning the instrument, use a dry cloth.
- Do not leave the tester exposed to direct sunlight or in a hot and humid location such as the inside of a car, for any prolonged length of time.

NOTE

- Radiation immunity affects the accuracy of 300 30 and 300 31 testers under the conditions specified in EN 61326-1.
- If equipment generating strong electromagnetic interference is located nearby, the testers may malfunction.