

## DESCRIPTION

### CONTROL UNIT

The microprocessor-controlled soldering station WSD81/WSL is part of a family of units that have been developed for industrial manufacturing and for the rework and repair sector. The WSD81/WSL Soldering systems offer digital microprocessor control as well as the use of high-quality Platinum RTD (Resistance Temperature Detector) type sensor to provide precise, responsive temperature control at the soldering tip. The soldering tools are automatically recognized by the WSD81/WSL and the corresponding control parameters are assigned.

A digital readout, grounded soldering iron tip, zero power switching and antistatic design of the control unit and iron, complete the high quality standards established by Weller. The WSD81/WSL Soldering Systems offer the capability of connecting an external calibration unit, which further increases the variety of functions of the soldering systems. With the optional WCB1 Calibration unit, it is possible to initiate a "Setback" feature (as well as an "Auto Off" function), a "Lockout" function, Factory Default settings, as well as a custom "Tip Offset" feature.

The temperature is adjustable in the range of 150°F and 850°F (66°C and 454°C) using the "UP" and "Down" Scroll Keys. The "Set" and the "Read" values are digitally displayed. A blinking red LED in the LSD (Least Significant Digit) signals that the preset temperature has been reached. This serves as a visual indicator to monitor the heater control.

### SOLDERING HANDPIECES

**WSP80:** The WSP80 Soldering Pencil is characterized by its capacity for reaching soldering temperatures quickly and precisely. Its slim design and power rating of 80 watts allows for use in applications from extremely fine to high-temperature soldering. Due to the extremely fast heat up and recovery time of the WSP80 Iron, soldering may be continued very quickly, once the soldering tips are interchanged.

**WMP:** The "New" Weller WMP Micro Soldering Pencil is ideal for work on professional SMT electronics. An improved "Tip to Grip" ratio between the handle and the soldering tip ensures improved handling of the 65W soldering iron when performing the finest of soldering tasks.

See "Accessories" for additional tools.

### TECHNICAL DATA

Dimensions in inches/mm:	6.5 / 166 x 4.5 / 115 x 4.0 / 101 (l x w x h)
Supply voltage (8):	120VAC - 50/60 Hz
Power input:	95 watts
Fuse (9):	T1,0 A (120VAC - 60Hz)
Temperature control range:	150°F - 850°F (65.5°C - 454°C)
Absolute Accuracy:	Average tip temperature can be "Offset" to $\pm 9^\circ$ F ( $\pm 5^\circ$ C) at no load
Line Cord:	3 Wire; UL Recognized
Control Setting Resolution:	1° F (1° C)
Stability:	$\pm 10^\circ$ F ( $\pm 6^\circ$ C) per MIL-STD-2000
Ambient Temperature Range:	60° F to 110° F (16° C to 44° C)

The Weller WSD81/WSL Soldering Stations are designed to meet all applicable standards: MIL-STD-2000 MIL-S-45743, W-S-570, AS WELL AS DOD-STD-1686.

Housing and tool handles are made with Electrostatic Protective Materials as required in MIL-B-81705.

Housing passes Static Decay Test per Federal Test Method Std. No. 101, Method 4046.

## OPERATING INSTRUCTIONS

Unpack the unit carefully. Position the workstand on the appropriate area of the workbench. Insert tool in holder and connect tool plug to the receptacle on the power unit (7). Rotate the plug housing Clockwise (CW) to lock the plug into the receptacle. Check that the power supply corresponds to the specifications on the base unit label and that the power switch (1) is in the "OFF" position.

## SETTING THE TEMPERATURE

The digital display (2) shows the actual tip temperature. By depressing the "UP" or "DOWN" keys (3) (4) the digital display (2) switches to the "Set" temperature. The set point may be changed by repeatedly depressing the "UP" or "DOWN" keys (3) (4) or by continuously depressing the "UP" or "DOWN" keys (3) (4) in the desired direction. Pressing the button will change the set point quickly. The digital display (2) returns automatically to the "Read" value, approximately 2 seconds after releasing the "UP" or "DOWN" keys (3) (4).

## STANDARD "SETBACK"

If the soldering tool is not used within a period of 20 minutes, the temperature will be automatically reduced to a standby temperature of 300° F (150° C). After the unit has reached the "Setback" mode, three setback periods the station will continue to function at the reduced temperature (300° F/ 150° C), for approximately 1one hour (60 min.). At this time, the "AUTO OFF" function will be activated and the soldering iron and power to the station, will be switched off.

Activating the standard "Setback" function: When switching the unit "On", depress and hold the "UP" button until "ON" appears in the display. Use the same process to switch the unit "Off". "OFF" will appear in the display (the station will be shipped in the "Off" state). Certain applications may not be recognized by the "Loading Effect" or "Temperature Drop" on the tool and may require more frequent wiping of the tip on the damp sponge, to recognize use.

## MAINTENANCE

The interface between the heating element/sensor and the tip of the soldering iron should not be exposed to dirt, foreign materials or physically damaged, since this affects the precision of the temperature control.

## INSTRUCTIONS FOR USE

During the initial heating of the iron, pre-tin the wettable surface of the tip with solder. This removes any oxidation or contamination on the working area of the tip, which may have occurred during storage or shipment. Always keep the tip tinned and wipe the tip clean before using. Once the tip has been cleaned on a damp soldering tool sponge, re-tin the tip with a light, fresh coating of solder. This will help to transfer the heat from the tip to the work. Do not use aggressive fluxing agents. To do so will greatly affect the working life of the tip. Do not file or mechanically abrade the soldering iron tip. This will damage the Iron plating of the tip and cause the tip to be rendered useless, much quicker than with normal cleaning practices.

## WMP/WSP80 SOLDERING IRON SELECTION

The WSD81/WSL series of soldering stations are designed to allow either the WMP or WSP80 iron to be used without any required changes to be made to the stations. This is due to the high precision RTD (Resistance Temperature Detector) Sensor used in the Weller family of electronic soldering stations.

## USING THE WCB1 CALIBRATOR WITH THE WSD81 / WSL SOLDERING SYSTEMS

The following functions are possible when using the WCB1 Calibrator.

**Offset Mode:** The actual tip temperature of the soldering iron can be changed by  $\pm 72^{\circ}\text{F}$  ( $\pm 40^{\circ}\text{C}$ ) by use of the temperature "Offset" feature on the WCB1 Calibrator.

**Setback Mode:** A reduction of the set point temperature to 300°F (150°C) (“Setback” mode). The setback time can be controlled from 0-99 minutes after the soldering station has switched to standby mode. After a period equal to three times the setback time, the “Auto Off” function is activated. Power to the soldering iron and station are switched “Off” (indicated by a flashing segment on the display).

**Lockout Mode:** Locking the set point temperature. Settings cannot be changed after the soldering station has been “Locked”.

**°F/°C Mode:** Switching the temperature display from °F to °C, and vice versa.

**Window Mode:** Limitation of the temperature range to a maximum of ± 178° F (± 99° C) based on a locked temperature resulting from the “Lockout” function. The locked temperature represents the median point of the adjustable temperature range. This allows the station to be adjusted within a range of temperatures that are considered allowable for certain, similar applications (i.e. 700° F Median Temperature ± 50° F Window, allows the station to be adjusted between the range/window of 650° F to 750° F).

**Cal:** This function allows the soldering station to be Reset to “Factory Default Settings”.

## SAFETY INSTRUCTIONS

The manufacturer assumes no liability for uses other than those described in the operating instructions, or for unauthorized alterations.

These operating instructions and warnings should be read carefully and kept in an easily visible location near the soldering iron. Non-observance of these warnings can result in accidents, injury or risks to health.

## ACCESSORIES

WSP80	Soldering Pencil, 80W
WSP80AP	Soldering Pencil, 80W
0052503070	Thermal Stripper (no blades)
0058725723	Cutting Knives Set WST-20
0053313399	Thermal Tweezer Set WTA50
0052702899	Preheating Plate WHP80
0052503099	Thermal Stripper WST20
0053118199	External Input Unit WCB1
WMPH	Iron Holder, WSL
WPH81	Iron Holder, WMP
WSLPU	Power Unit, WSL
WSD81PU	Power Unit, WSD80

## CONTENTS

<b>WSD81</b>	<b>WSL</b>	<b>WSD81/WSLPU</b>
Control Unit WSD81PU	Control Unit WSLPU	Control Unit
Soldering Iron WSP80	Soldering Iron WMP	Power Cord 120VAC
Power Cord 120VAC	Power Cord 120VAC	Operating Manual
Operating Manual	Operating Manual	
Soldering Iron Stand	Soldering Iron Stand	

**Illustration: Exploded view, see Pages 5-6**

## WSD81/WSL MICROPROCESSOR-CONTROLLED SOLDERING STATION

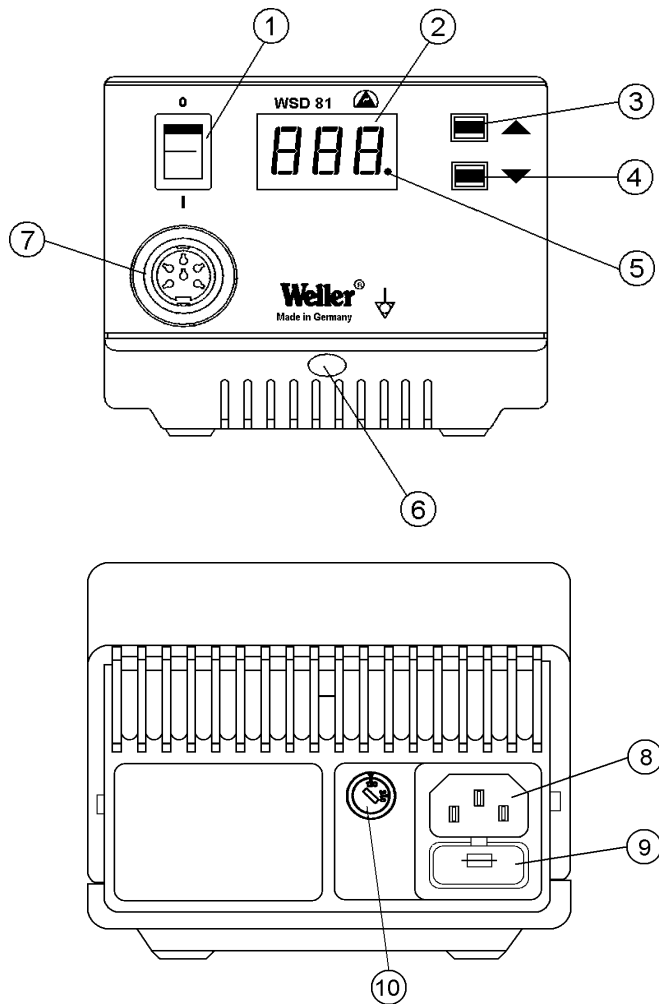

### FEATURES

1. Power Switch
2. Digital display
3. "UP" Scroll Key
4. "DOWN" Scroll Key
5. LED – Heat Control Indicator
6. Equipotential (Ground) Connection Port (For European Products Only)
7. Soldering Iron Receptacle
8. Power supply connector
9. Fuse / Fuse Holder
10. Voltage selection switch (Not for US Products)

# EXPLODED VIEW WSD81

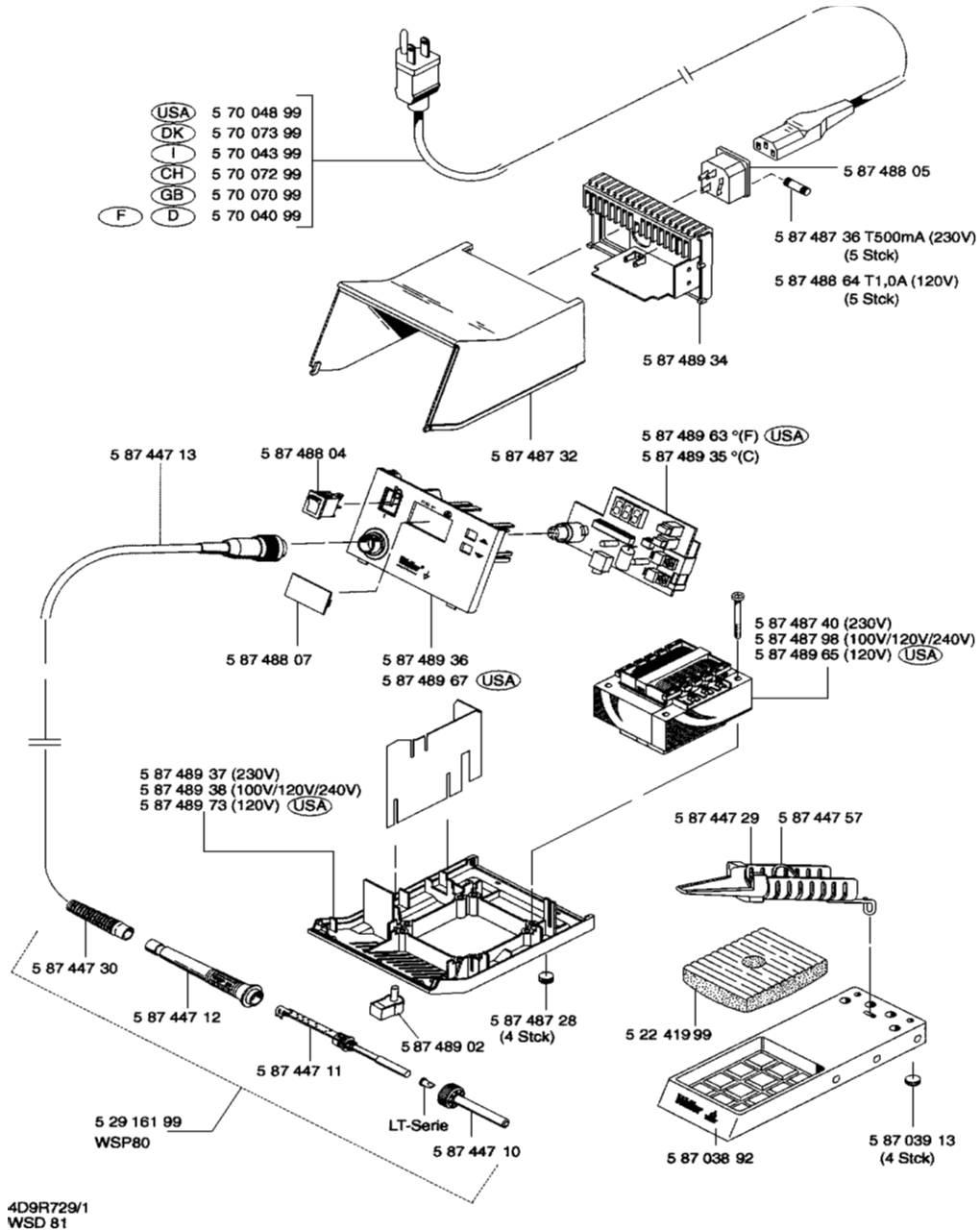

# EXPLODED VIEW WSL

