

WELLER® MT1500 SOLDERING TIP NUMBERS AND DESCRIPTIONS

NOTE: TIP HEATERS ARE BURNED IN BEFORE SHIPMENT, SOME DISCOLORATION AROUND HEATER IS NORMAL

TIP NO.	DESCRIPTION	TIP SHAPE	TIP NO.	DESCRIPTION	TIP SHAPE	TIP NO.	DESCRIPTION	TIP SHAPE
MT200 Series Tips Heater Diameter .375" (9.5mm) Dia. And Reach "L"			MT600 Series Tips Heater Diameter .200" (5.1mm) Dia. .375" (9.5mm) Dia. And Reach "L" .848" (21.5mm)			MT609	Conical .023"D x .600"L (0.58mm D x 15.24mm L)	
MT202	Conical .030" D x 1.0" L (0.76mm D x 25.4mm L)		MT601	Screwdriver .070"W x .385"L x .023"T (1.78mm W x 9.78mm L x 0.58mm T)		MT610	Screwdriver .200"W x .350"L x .030"T (5.08mm W x 8.89mm L x 0.76mm T)	
MT203	Conical, Mil-Spec. .030"D x 1.0"L (0.76mm D x 25.4mm L)		MT602	Screwdriver .100"W x .390"L x .030"T (2.54mm W x 9.91mm L x 0.76mm T)		MT611	Chisel .060"W x .610"L x .010"T (1.52mm W x 15.49mm L x 0.25mm T)	
MT204	Conical, Non-Wetting .030"D x 1.0"L (0.76mm D x 25.4mm L)		MT603	Conical Bent .020"D x .600"L (0.51mm D x 15.24mm L)		MT612	Conical Bent .050"D x .880"L (1.27mm D x 22.35mm L)	
MT211	Screwdriver .045"W x 1.0"L x .010"T (1.14mm W x 25.4mm L x 0.25mm T)		MT604	Screwdriver .060"W x .390"L x .025"T (1.52mm W x 9.91mm L x 0.64mm T)		MT613	Conical .020"D x .520"L (0.51mm D x 13.21mm L)	
MT212	Screwdriver, Non-Wetting .045"W x 1.0"L x .004"T (1.14mm W x 25.4mm L x 0.10mm T)		MT605	Conical Bent .016"D x .560"L (0.41mm D x 14.22mm L)		MT614	Chisel .100"W x .190"L x .015"T (2.54mm W x 4.83mm L x 0.31mm T)	
MT220	Calibration, Conical .030"D x 1.0"L (0.76mm D x 25.4mm L)		MT606	Conical .016"D x .530"L (4.06mm D x 13.46mm L)		MT615	Conical .030"D x .390"L (0.96mm D x 9.91mm L)	
MT221	Screwdriver .031"W x 1.0"L x .010"T (0.79mm W x 25.4mm L x 0.25mm T)		MT607	Bevel .020" D x .530"L x .010"T (0.51mm D x 13.46mm L x 0.25mm T)		MT616	Bevel .032"D x .560"L x .016"T (0.81mm D x 14.22mm L x 0.41mm T)	
MT300 Series Tips Heater Diameter .375" (9.5mm) Dia. And Reach .150" (3.8mm) Dia. .165" (4.2mm) Dia. "L" .795" (20.2mm)			MT608	Bevel .040"D x .560"L x .020"T (1.02mm D x 14.22mm L x 0.51mm T)		MT620	Calibration Screwdriver .070"W x .385"L x .023"T (1.78mm W x 9.78mm L x 0.58mm T)	
MT301	Screwdriver .047"W x .200"L x .015"T (1.19mm W x 5.1mm L x 0.38mm T)							
MT302	Conical .015"W x .200"L (0.38mm W x 5.08mm L)							
MT303	Conical, Bent .015"D x .200"L (0.38mm D x 5.08mm L)							
MT320	Calibration, Screwdriver .047"W x .200"L x .015"T (1.19mm W x 5.08mm L x 0.38mm T)							

WELLER® MT1500 SMD TIP NUMBERS AND DESCRIPTIONS

NOTE: TIP HEATERS ARE BURNED IN BEFORE SHIPMENT, SOME DISCOLORATION AROUND HEATER IS NORMAL

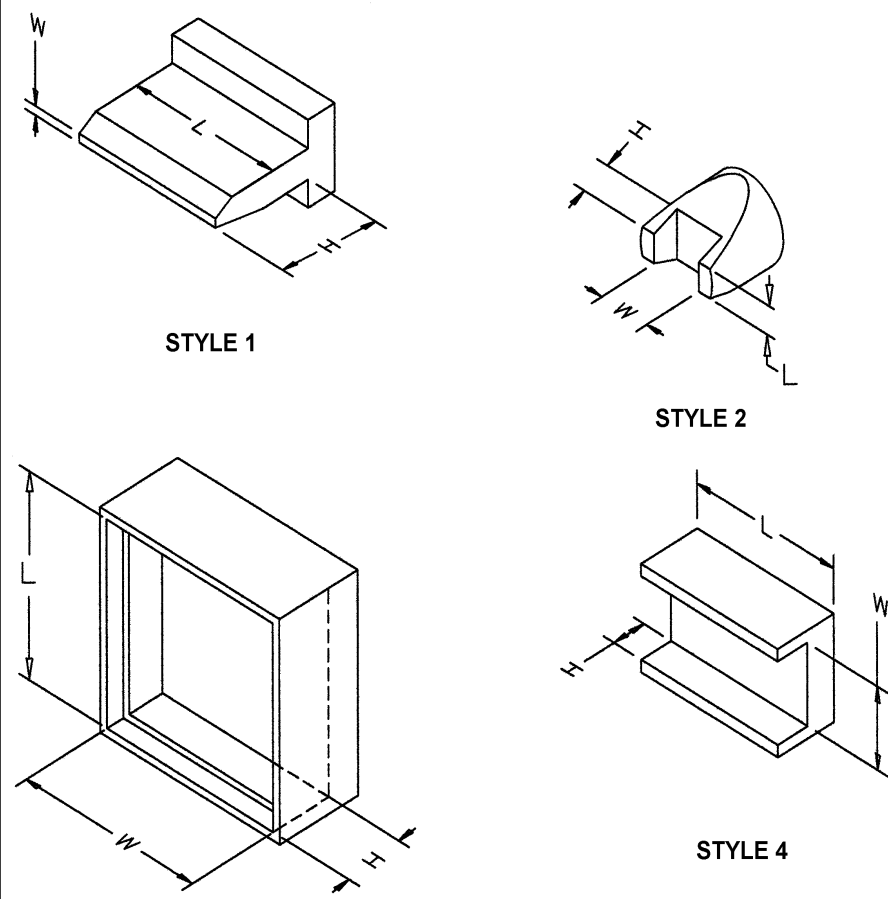
		PART NO.	STYLE NO.	L INCHES MM	W INCHES MM	H INCHES MM
		MT617	1	.410 / 10.414	.022 / .559	.280 / 7.112
MT618	2	.070 / 1.778	.135 / 3.429	.070 / 1.778		
MT619	4	.410 / 10.414	.200 / 5.08	.090 / 2.286		
MT621	4	.180 / 4.572	.200 / 5.08	.090 / 2.286		
MT622	2	.060 / 1.524	.090 / 2.286	.070 / 1.778		
MT623	4	.450 / 11.43	.270 / 6.858	.090 / 2.286		
MT624	2	.100 / 2.540	.068 / 1.727	.055 / 1.397		
MT625	2	.090 / 2.286	.190 / 4.826	.070 / 1.778		
MT626	2	.105 / 2.667	.303 / 7.696	.150 / 3.81		
MT1201	3	.500 / 12.7	.500 / 12.7	.150 / 3.81		
MT1202	3	.410 / 10.414	.410 / 10.414	.150 / 3.81		
MT1203F	3	.682 / 17.323	.682 / 17.323	.235 / 5.969		
MT1204	3	.600 / 15.24	.500 / 12.7	.150 / 3.81		
MT1205	1	.820 / 20.828	.022 / .559	.280 / 7.112		
MT1206	1	.620 / 15.748	.022 / .559	.280 / 7.112		
MT1207	4	.520 / 13.208	.375 / 9.525	.125 / 3.175		
MT1208F	3	.965 / 24.511	.965 / 24.511	.235 / 5.969		
MT1209	4	.740 / 18.796	.355 / 9.017	.125 / 3.175		
MT1210	4	.720 / 18.288	.375 / 9.525	.125 / 3.175		
MT1211	4	.620 / 15.748	.375 / 9.525	.125 / 3.175		
MT1212	3	.540 / 13.716	.340 / 8.636	.150 / 3.81		
MT1213	3	.915 / 23.241	.680 / 17.272	.150 / 3.81		
MT1214F	3	1.165 / 29.591	1.165 / 29.591	.235 / 5.969		