

Agilent 83236B

PCS Interface

Product Overview

Wireless test solutions for your PCS-band phones

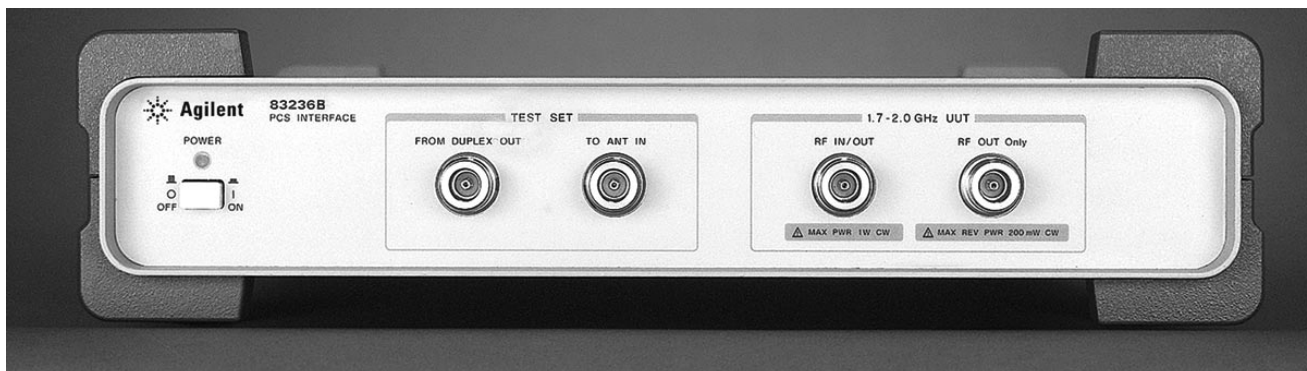

Cellular to PCS frequency translator for Agilent Technologies' successful 800 MHz test sets

- 8920B Option 800 TDMA Mobile Test Set
- 8924E CDMA Mobile Station Service Test Set

TDMA and CDMA Test Solutions

The Agilent Technologies 83236B PCS Interface is a cellular to PCS frequency translator. When combined with Agilent Technologies TDMA and CDMA RF test sets, it provides PCS test solutions for your TDMA and CDMA PCS phones and cell sites.

83236B PCS-band test solutions build on the following successful 800 MHz test sets.

- 8920B Option 800 TDMA Mobile Test Set
- 8924E CDMA Mobile Station Service Test Set

For configuration information, refer to the Agilent 8920B Configuration Guide, pub. number 5968-5919E.

PCS-band Coverage

The 83236B translates 800 MHz measurement capabilities to the 1710 to 1990 MHz frequency range. This frequency range covers the International (1710 to 1880 MHz), Korean (1715 to 1870 MHz), and North American (1850 to 1990 MHz) PCS bands.

Measurement Accuracy

Power measurement accuracy and speed are maintained at PCS-band frequencies with an internal power meter for measurements on CW, CDMA, and TDMA ($\pi/4$ pulsed or continuous) signals.



Agilent Technologies

Innovating the HP Way

Agilent 83236B Specifications

Specifications describe the instrument's warranted performance after a 30-minute warm-up period and are valid over the entire operating range unless otherwise noted.

Supplemental Characteristics are intended to provide additional information useful in applying the instrument by giving typical, but non-warranted performance parameters. These are shown in italics or labeled as "typical," "usable to," or "nominal."

Generator Output Path¹

(RF IN/OUT and RF OUT Only connector)

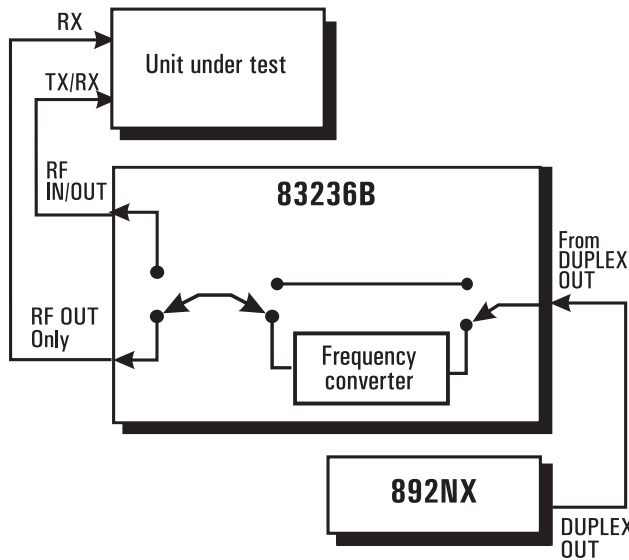

Generator Output Path

Frequency

Frequency Range:

Through Path:

824 MHz to 849 MHz
869 MHz to 894 MHz

Conversion Path:

1710 MHz to 1785 MHz
1805 MHz to 1910 MHz
1930 MHz to 1990 MHz

Frequency Settling Time: <10 ms

Output

RF IN/OUT Connector:

Output Level Range: -130 dBm to -20 dBm

RF OUT Only Connector:

Output Level Range: -130 dBm to -10 dBm

Level Accuracy:

±1.8 dB, @ 25 °C ±10 °C
±2.0 dB, @ 0 °C to 55 °C
Typically ±1.0 dB

Output Level Settling Time: <80 ms

Spectral Purity (83236B only)

Spurious

Type of Spurious	Frequency (MHz)		
	824 to 849 869 to 894	894 < to <1710	1710 to 1990
Harmonic	<-30 dBc	—	<-30 dBc
Non-Harmonic	<-60 dBc*	<-25 dBc**	<-60 dBc*

* Offsets >5 kHz

** For carrier levels >-100 dBm

SSB Phase Noise: <-100 dBc/Hz at 20 kHz offset from carrier

- To meet generator output path specifications, the input signal must be from the Test Set with the following characteristics:
Frequency Range: 810 MHz to 995 MHz
Level Range: -70 dBm to -7 dBm.

Analyzer Input Path

(RF IN/OUT connector)

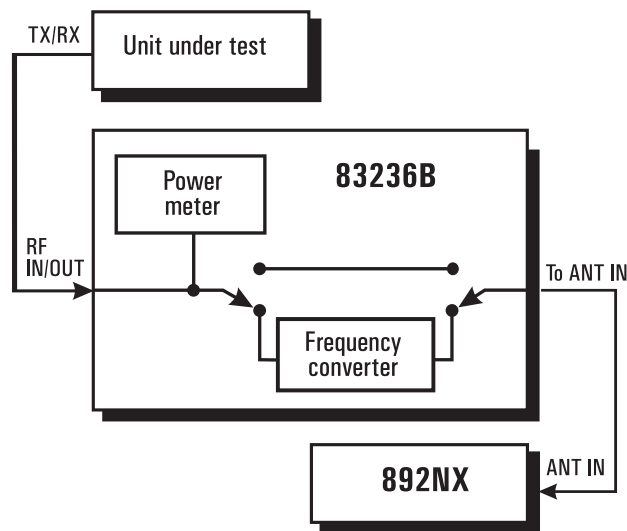

Analyzer Input Path

Frequency

Frequency Range:

Through Path:

824 MHz to 849 MHz

869 MHz to 894 MHz

Conversion Path:

1710 MHz to 1785 MHz

1805 MHz to 1910 MHz

1930 MHz to 1990 MHz

Max Input Level: The maximum allowable average power depends on the unit under test as follows:

Subscriber Unit Test:

Single carrier TDMA and FM: 40 dBm (10 W)

CDMA: 37 dBm (5 W)

Base Station Test:

Single carrier TDMA and FM: 40 dBm (10 W)

CDMA and multi-carrier: 30 dBm (1 W)

Max Peak Instantaneous Signal: 30 V

Spectral Purity

Integrated Spurious and Phase Noise: <-57 dBc in a 100 Hz to 32 kHz bandwidth

Spurious Level: <-60 dBc at ≥ 5 kHz and ≤ 20 MHz offset from carrier

Power Measurement

Frequency Range:

824 MHz to 849 MHz

869 MHz to 894 MHz

1710 MHz to 1785 MHz

1805 MHz to 1910 MHz

1930 MHz to 1990 MHz

Measurement Range:

Subscriber Unit Test

Single carrier TDMA and FM: -13 dBm to 40 dBm (50 μ W to 10 W)

CDMA: -13 dBm to 37 dBm (50 μ W to 5 W)

Base Station Test

Single carrier TDMA and FM: -13 dBm to 40 dBm (50 μ W to 10 W)

CDMA and multi-carrier: -13 dBm to 30 dBm (50 μ W to 1 W)

Accuracy: $\pm 5\%$ of reading ± 2.5 μ W @ 23 °C ± 10 °C after power meter zero and calibration $\pm 10\%$ of reading ± 2.5 μ W

Resolution: 0.01 dB or 10 μ W

Reference Specifications

(For proper operation, this instrument must be locked to an external 10 MHz reference.)

REF IN

Input Frequency: 10 MHz

Input Level Range: -5 dBm to +10 dBm

REF OUT

Output Frequency: 10 MHz

Output Level: -1 dBm

Accuracy: Buffered signal from REF IN, or 10 MHz \pm 10 ppm (if no external reference is connected to REF IN)

Remote Control

GPIB: Agilent Technologies' implementation of IEEE Standard 488.2

Serial Port:

Connector type: D-SUB15(F)

Interface: RS-232C

General Specifications

Isolation between "RF IN/OUT" and "RF OUT Only": >40 dB

Size: 84 H x 340 W x 500 D mm

Weight: 5.6 kg

Operating Temperature: 0 °C to 55 °C

Operating Humidity: 15 to 95% RH @ 40 °C

Operating Altitude: 0 to 2000 meters

Non-operating Temperature: -55 °C to 70 °C

Non-operating Humidity: To 90% RH @ 65 °C

Non-operating Altitude: 0 to 4572 meters

Power: AC 90 to 132 V, 198 V to 264 V, 47 to 63 Hz, 100 VA max

Others

Safety: Complies with IEC 1010-1:1990 + A1:1992/EN 61010-1:1993 Certified by CSA-C22.2 No. 231-M89

EMC:

Radiated Emission: Complies with EN 55011:1991/CISPR 11:1990- Group 1, Class A

Flicker: Complies with EN 61000-3-3:1995/ IEC 1000-3-3:1994

Electro-Static Discharge: EN 50082-1:1992/IEC 801-2:1991
-4 kV CD, 8 kV AD

Radiated Immunity: EN 50082-1: 1992/IEC 801-3: 1984 -3 V/m

Note: When tested at 3 V/m according to IEC 801-3/1984, the output level accuracy will be within specifications over the full immunity test frequency range of 26 to 1000 MHz except when the analyzer frequency is identical to the transmitted interference signal test frequency.

Electrical Fast Transient/Burst: EN 50082-1:1992/IEC 801-4:1988
- 0.5 kV Signal Lines, 1kV Power Lines

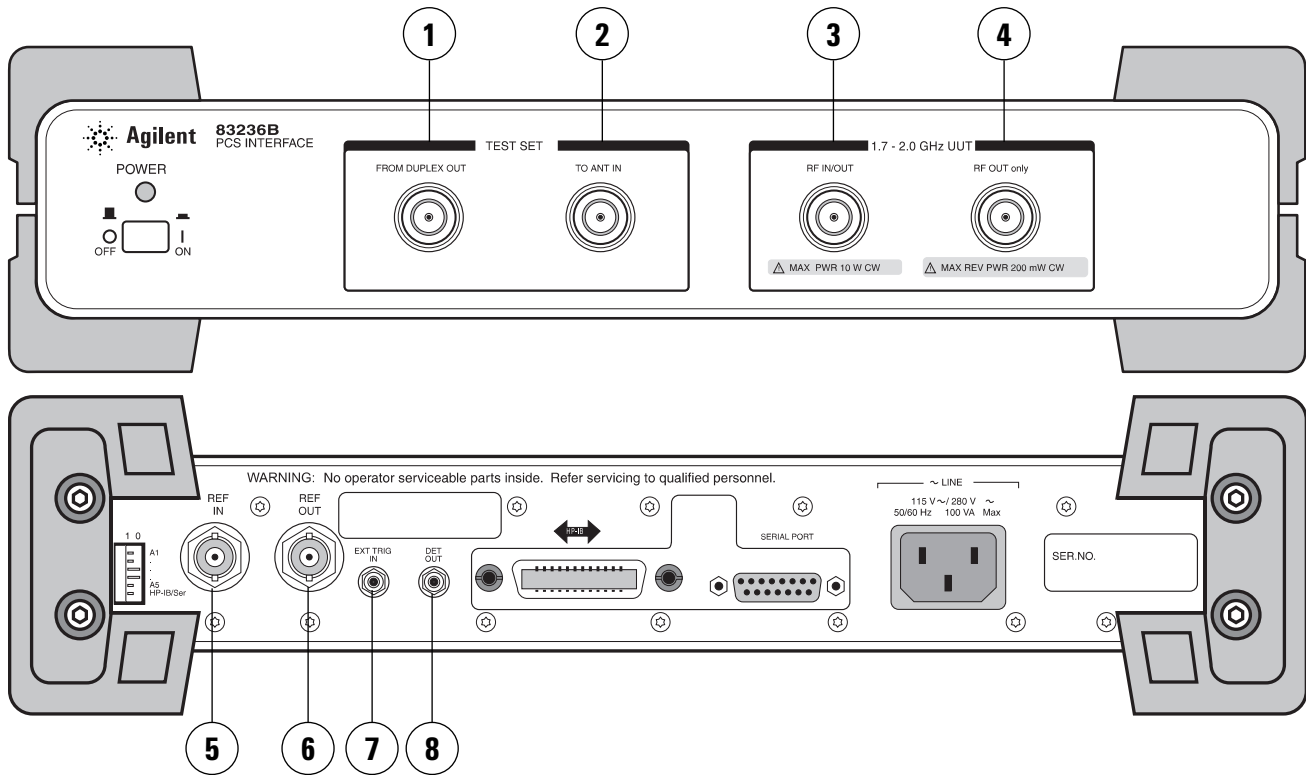

Connectors

- 1. FROM DUPLEX OUT:** (Input from 892NX)
Input Impedance: 50 Ω (nominal)
Connector Type: Type N (F)
SWR: <1.3:1
Input Frequency Range: 810 MHz to 995 MHz
Input Level Range: -70 dBm to -7 dBm
- 2. To ANT IN:** (Output to 892NX)
Frequency Range: 650 MHz to 940 MHz
Output Impedance: 50 Ω (nominal)
Connector Type: Type N (F)
SWR: <2.3:1
- 3. RF IN/OUT:** (Input/Output to UUT)
Input/Output Impedance: 50 Ω (nominal)
Connector Type: Type N (F)
SWR: <1.2:1
Applied Power:
Subscriber Unit Test
Single carrier TDMA and FM: 40 dBm (10 W)
CDMA: 37 dBm (5 W)
Base Station Test
Single carrier TDMA and FM: 40 dBm (10 W) CDMA and multi-carrier: 30 dBm (1 W)
Max Peak Instantaneous Signal: 30 V
- 4. RF OUT Only:** (Output to UUT)
Output Impedance: 50 Ω (nominal)
Connector Type: Type N (F)
SWR: <1.6:1
Reverse Power Protection: 200 mW CW max
- 5. REF IN:** (Input from 892NX)
Input Frequency: 10 MHz
Input Level Range: -5 dBm to +10 dBm
Input Impedance: 50 Ω (nominal)
Connector Type: BNC (F)
- 6. REF OUT:** (Output)
Output Frequency: 10 MHz
Output Level: -1 dBm
Output Impedance: 50 Ω (nominal)
Connector Type: BNC (F)
- 7. EXT TRIG IN:** (Input for TDMA)
External Trigger Signal: (Required for TDMA RF input level range -13 dBm to -5 dBm)
Input Level: TTL
Input Impedance: >1 k Ω at 1 MHz (nominal)
Triggering Type: Positive edge
Connector Type: SMC (M)
- 8. DET OUT:** (Output for CDMA)
Output Impedance: 50 Ω (nominal)
Connector Type: SMC (M)

Ordering Information

83236B PCS Interface

Options

AX4 Rack flange kit without handles

1AB Benchtop cabinet kit (for use with the Agilent 8924E)

Agilent Technologies' Test and Measurement Support, Services, and Assistance

Agilent Technologies aims to maximize the value you receive, while minimizing your risk and problems. We strive to ensure that you get the test and measurement capabilities you paid for and obtain the support you need. Our extensive support resources and services can help you choose the right Agilent products for your applications and apply them successfully. Every instrument and system we sell has a global warranty. Support is available for at least five years beyond the production life of the product. Two concepts underlie Agilent's overall support policy: "Our Promise" and "Your Advantage."

Our Promise

"Our Promise" means your Agilent test and measurement equipment will meet its advertised performance and functionality. When you are choosing new equipment, we will help you with product information, including realistic performance specifications and practical recommendations from experienced test engineers. When you use Agilent equipment, we can verify that it works properly, help with product operation, and provide basic measurement assistance for the use of specified capabilities, at no extra cost upon request. Many self-help tools are available.

Your Advantage

"Your Advantage" means that Agilent offers a wide range of additional expert test and measurement services, which you can purchase according to your unique technical and business needs. Solve problems efficiently and gain a competitive edge by contracting with us for calibration, extra-cost upgrades, out-of-warranty repairs, and on-site education and training, as well as design, system integration, project management, and other professional services. Experienced Agilent engineers and technicians worldwide can help you maximize your productivity, optimize the return on investment of your Agilent instruments and systems, and obtain dependable measurement accuracy for the life of those products.

Get assistance with all your test and measurement needs at:
www.agilent.com/find/assist

Product specifications and descriptions in this document subject to change without notice.

Copyright © 1996, 2000 Agilent Technologies
Printed in U.S.A. 9/00
5965-5625E



Agilent Technologies

Innovating the HP Way

Test Equipment Depot - 800.517.8431 - 99 Washington Street Melrose, MA 02176

FAX 781.665.0780 - TestEquipmentDepot.com