



99 Washington Street
Melrose, MA 02176
Fax 781-665-0780
TestEquipmentDepot.com



Digital Thermometer/ Pyrometers

OWNER'S MANUAL

Covers Models:

- TIF7000
- TIF7000AC
- TIF7000FS
- TIF7000TP
- TIF7050
- TIF7500
- TIF7500A

TABLE OF CONTENTS



General Description	2
Features	2
Operating Instructions	3
Probe Descriptions	4
Specifications	9
Warranty and Repair Information	9
Español	10
Français	15
Deutsch	20

GENERAL INFORMATION

This owners manual covers multiple versions of the TIF7000 series Pyrometers. The differences are limited to the included probes as noted below.

The TIF digital pyrometers combine laboratory precision with unsurpassed speed and ease of use. Each of the standard probes supplied with the instrument is individually calibrated and completely interchangeable with any other 7000 series probe without loss of accuracy or readjustment. Several features of these units are not available in instruments costing a great deal more.

FEATURES

- ❑ Unequaled accuracy in its price range.
- ❑ Super-Fast settling time to 99%.
- ❑ Adjustment-free interchangeable probes.
- ❑ Switch selected for °F or °C.
- ❑ Custom fitted instrument case.
- ❑ Universally available coil cord connector.
- ❑ 9V battery life 6-12 months normal use.
- ❑ Display update 3 times per second.
- ❑ Large easily read display.
- ❑ Over Range indication.
- ❑ Low Battery indication.
- ❑ High impact ABS case and probe handles.
- ❑ Chromel-Alumel, type K thermocouple elements.
- ❑ Made in the U.S.A.
- ❑ One Year Warranty.

Included Probes (refer to pages 4-8 for descriptions.)

<u>Model</u>	<u>Included Probes</u>
TIF7000	7002,7003,7004
TIF7000AC	7002,7003,7007
TIF7000FS	7002,7003,7010
TIF7000TP	7002,7003,7008
TIF7050	7008 Only
TIF7500	7009 Only
TIF7500A	7010 Only

OPERATING INSTRUCTIONS

Battery Installation:

Use only good quality 9-Volt batteries (Eveready #216 or equivalent).

Slide the battery compartment end panel, located at the bottom of the unit, open in the direction indicated by the embossed arrow.

Snap the battery clip onto the battery terminal, making sure that the connectors mate tightly. Slide the battery into the compartment and close the panel.

Internal Ice Point Reference:

With no probe connected to the 7001 and the °F/°C switch in either position, press the On-Off switch; "000" will be displayed. An error of ± count may occur infrequently (See TIF7001 Section of this manual).

Battery Check:

A nearly dead battery (less than 7V) will decline rapidly in use. If any probe at ambient temperature is connected, the display will drop rapidly (i.e. 10-20°F in 10 seconds). There is no inherent source of drift in this instrument, therefore any apparent drift downward will indicate a weak battery.

The instrument may still provide accurate readings if the On-Off switch is cycled judiciously. For extra convenience, the case has been fitted with space for a spare battery.

Coiled Cord Connector:

The six foot coiled cord uses standard phone-type modular plugs. If it is changed, or a longer cord is used, the probes may need re-calibration.

Probe Calibration:

Remove the small plastic plug from the side of the probe handle. With the probe connected to the display and its tip immersed in ice water, adjust the exposed calibration screw to give a reading of 33°F. NOTE: Take care not to get any liquid into the probe handles, especially with respect to the 7002 Surface Probe and 7003 Air Probe.

Over Range:

A "1" followed by a blank display, indicates an over-range condition.

TIF7001 Display:

The TIF7001 contains the main analog and digital electronics, the °F/°C selection switch, On/Off switch and coil cord connector. All of the state of the art VLSI circuits, liquid crystal display and ancillary electronics are soldered to a shock mounted glass epoxy printed circuit board within the high impact ABS case. Neither the case nor the probe handles (also high impact ABS) should be subjected to temperatures above 250°F (+121°C).

OPERATING INSTRUCTIONS

In addition to processing and displaying the probe signal, the TIF7001 also supplies regulated voltage to the thermocouple compensation electronics in the probe handle.

Overall accuracy of A/D convertor and digital electronics is well within $\pm 1\%$ ± 1 count.

Included Probes:

See Page 2. There is also a wide range of specialized probes available as accessories for your meter, as described later.

PROBE DESCRIPTIONS

Surface Probe:

The TIF7002 Surface Probe (See Figure 1, below) is designed to provide ultra-fast and accurate temperature readings from -40°F to 1999°F (-40°C - $+1100^{\circ}\text{C}$). This is made possible by the use of a very stable, low-mass sensor that "floats" at the probe tip, protruding approximately $0.020"$ (0.5 mm); this provides a spring back action. Due caution should be exercised, to avoid damage to this assembly.

To measure the temperature of a surface, hold the probe tip at a right angle to the surface so that the sensor is in intimate contact. Press the push-button on the 7001 and read the temperature. If the surface is extremely irregular, rusty or corroded, such that a solid reading is not being obtained, do not use the probe tip as a scraper. Any such usage may damage the probe tip.

Accumulated grime may be carefully removed from the tip with a rag or stiff brush. Do not knock material off the tip by rapping the probe against a hard object. That action may break the ceramic insulator. The probe tip (only) may be immersed in solvent or a vapor degreaser, so long as none of the solvent gets into the probe handle.

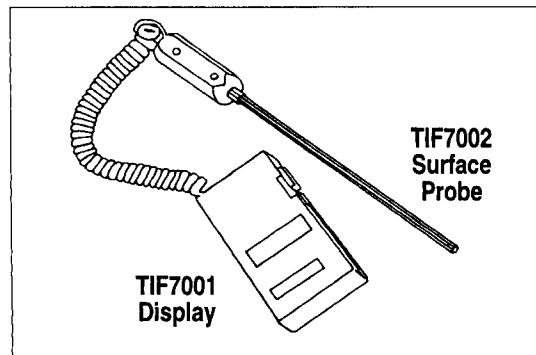

Figure 1

PROBE DESCRIPTIONS

Applications of the TIF7002

Cylinder Head, Exhaust Manifold, Radiator (external), Carburetor, Transmission, Wheel Bearings, A/C Condenser, A/C Evaporator, Cooking Grill, Strip Heater, Oven/Kiln, Compressor Head, Feed Water Pipe, Steam Traps, Electric Motor Case, Motor Bearing Cap, Chiller In/Out, HW Heater In/Out, Surface Losses, Freezer/Refrigerator.

Air Probe:

The TIF7003 Air Probe (See Figure 2 below) is designed to provide practically instantaneous air temperature readings from -40°F to over 1000°F (-40°C - $+538^{\circ}\text{C}$). Exposure time to temperatures above 550°F ($+280^{\circ}\text{C}$) should be kept short to avoid unnecessary, and possibly permanent, damage to the probe. The sensor wires (visible within the probe tip) are only $.004$ inches (0.1 mm) thick in order to provide rapid response, therefore, avoid application of severe mechanical shock (such as rotating fan blade). A broken probe wire will be indicated by the constant display of 00°F .

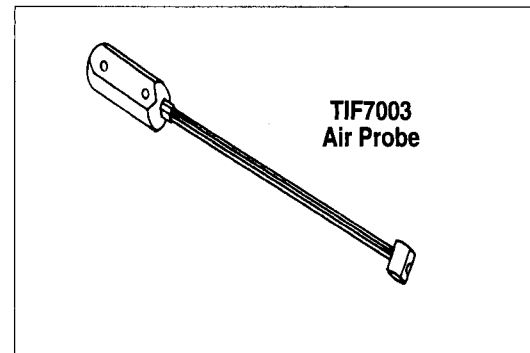

Figure 2

There are three considerations to be kept in mind when making air temperature measurement:

- In still air, the thermocouple will pick up radiated heat from the guard surrounding it. This effect will be noticed only in still air and will be eliminated by air or probe movement. There must be some movement of the air being measured relative to the probe.
- Any mass of air, whether in motion or static, is usually not at a uniform temperature throughout so that the average of several readings may be necessary to obtain a complete evaluation.
- The thermocouple must be heated (or cooled) by the air being tested. The extremely low mass of the TIF7003 will facilitate, but will not obviate this requirement.

The probe tip may be cleaned by immersion and mild agitation in a suitable solvent, so long as no solvent is allowed into the probe handle.

PROBE DESCRIPTIONS

Applications of the TIF7003

Ambient Temperature, A/C Diffusers, Returns, Auto A/C Inlet/Outlet, Auto Exhaust, Carburetor Air Inlet, Cooling A/C, Exhaust System Leak Checking, Refrigeration/Freezer Cold, Air Leaks, Outdoor Air Infiltration, HVAC System Temperature Balance, Pinhole/Gasket Leaks and Pressurized Systems.

Immersion Probe:

The TIF7004 Immersion Probe (See Figure 3, below) is designed to provide rapid, accurate liquid temperature reading from -40°F to +500°F (-40°C -+260°C). Exposure to temperatures above 500 °F (260°C) will degrade the teflon insulation.

CAUTION- DO NOT INSERT PROBE INTO OPERATING EQUIPMENT without being certain that there is no way that the probe will be caught or interfere with the equipment. Severe damage to the equipment and probe may otherwise occur.

Application of the TIF7004

Ambient, Auto Crankcase, Auto Transmission, Lubricant Sumps, Cooling Tower, Domestic H.W. , Live Steam, Deep Fryer, Pool Heater, Hot Tar, Food Processing, Photo Processing, Refrigerator/Freezer, Plastics Molding/Extrusion, and/or Chemical Processing. In otherwise inaccessible locations as Air Probe or Surface Probe to determine Operating Temp-Hot/Cold Spots/Htg/Cooling efficiency.

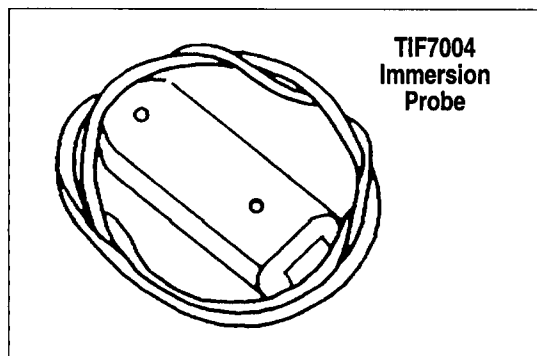

Figure 3

“Superheat” Probe:

The TIF7007 “Superheat” Probe (See Figure 4, pg. 7) is a twin element differential probe which will give a direct reading of the temperature difference between any two points to which the elements are applied . The range from each element is -40 to +300°F . *This probe is designed to give a reading in the Fahrenheit range only; it will not read correctly in Celsius.*

PROBE DESCRIPTIONS

Applications of the TIF7007

Temperature drop across condensing units; across air conditioning evaporators (Superheat), cooling efficiency of car radiators, oil coolers and skin temperature differences in veterinary work.

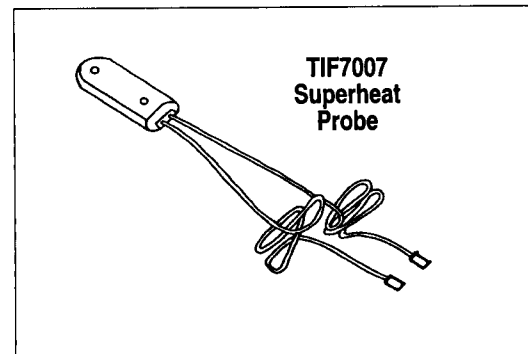

Figure 4

Tire Probe:

The TIF7008 Tire Probe (See Figure 5, below) is a short, penetrating probe with a 3/16" (4.76 mm) long pointed tip, designed to penetrate tread or shoulder rubber on tires. The temperature range is -40 + 400°F (-40°C - +205°C).

Applications of the TIF7008

Race car tires and/or truck tires.

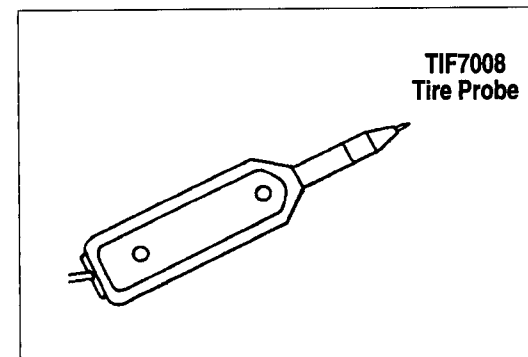

Figure 5

General Purpose Probe:

The TIF7009 General Purpose Probe (See Figure 6, pg. 8) is a 36" (91.5 cm) long, flexible probe which can be used for a wide range of surface and air temperature measurement. It can be used up to 1000°F (+538°C) before its synthetic insulation will begin to deteriorate.

PROBE DESCRIPTIONS

Applications of the TIF7009

Surface measurements on rough casting (such as manifolds) where the TIF7002 cannot maintain good thermal contact. Air Temperatures in Ovens, Refrigerators, and Freezers where the probe is thin enough to easily pass a closed door seal, Motor Bearings and Catalytic Converters.

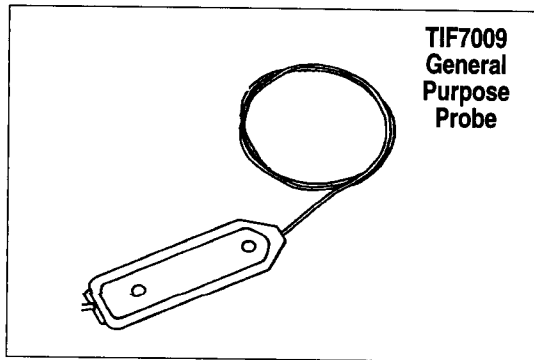

Figure 6

Penetrating Probe:

The TIF7010 Penetrating Probe (See Figure 7, below) is a 1/8" (3.175 mm) diameter type 304 stainless steel probe, 4 1/2" (11.5 cm) long, sealed at the end and designed to penetrate any soft or liquid material to check internal temperatures. The useful range is from -40 to +1000°F (-40 to +538°C).

Applications of the TIF7010

Refrigerated meat, fish, poultry, fruit and vegetables, high viscosity fluids and semisolids such as asphalt and molten plastics and Plating baths.

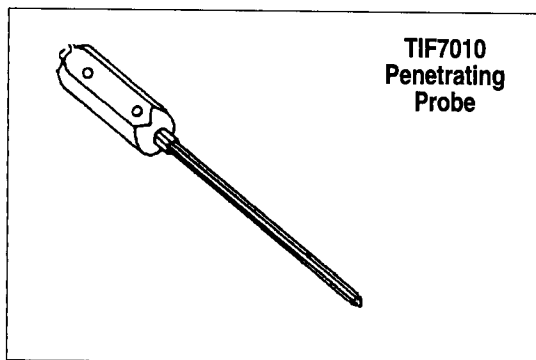

Figure 7

SPECIFICATIONS

Range: -40°F to 1999°F
-40°C to 1100°C

Resolution: ±1°

Repeatability: ±1°

Accuracy: ± 1%, ± 1 digit from 32-212°F (0°-100°C)
± 2%, ± 2 digits for the Full Range

Probe Response Time: (To 99% of reading)

7002	10 Sec.	7003	2 Sec.
7004	3 Sec.	7007	3 Sec.
7008	2 Sec.	7009	2 Sec.
7010	8 Sec.		

Max. Temperature:

7002	1999°F (1100°C)	7003	1000°F (538°C)
7004	500°F (260°C)	7007	300°F
7008	400°F (205°C)	7009	1000°F (538°C)
7010	1000°F (538°C)		

Operating

Temperature: 32° to 125°F (0° to +52°C)

Storage

Temperature: -40° to 140°F (-40° to 60°C)

Weight: 5 oz. (140 g) plus probe and cable (excludes Battery).

Dimensions: 5" x 2.4" x 1" (12.7 x 6 x 2.54 cm)

Battery type: Eveready #216 or equivalent (9v)

Battery Life: > 6 months with normal use.

WARRANTY AND REPAIR

Limited Warranty and Repair/Exchange Policy

This instrument has been designed and manufactured to provide unlimited service. Should the unit be inoperative, after performing the recommended maintenance, a no-charge repair or replacement will be made to the original purchaser if the claim is made within one year from the date of purchase. This warranty applies to all repairable instruments that have not been tampered with or damaged through improper use.

This warranty does not cover batteries or any other materials that wear out during normal operation of the instrument.

Returning Your Unit For Repair

Before returning your instrument for repair please make sure that you have carefully reviewed this manual to determine if the problem can be easily repaired. Make sure that the **batteries** are working properly **BEFORE** returning the unit.

If the instrument still fails to work properly return the unit to the place of purchase.