



99 Washington Street
Melrose, MA 02176
Phone 781-665-1400
Toll Free 1-800-517-8431



Visit us at www.TestEquipmentDepot.com

LanRoamer™ Tester/Analyzer

User's Guide

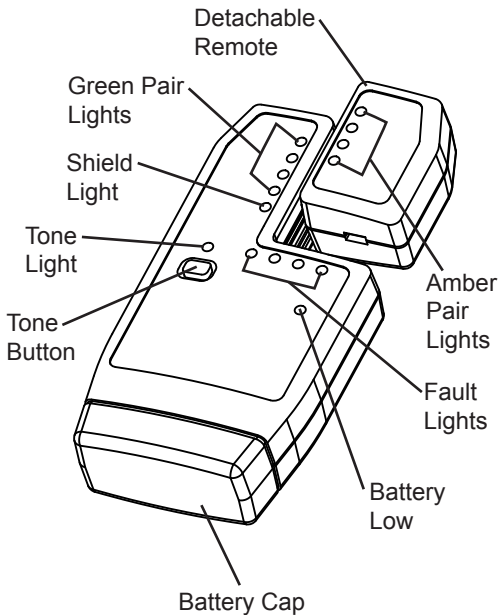

Warning!

Do not attach to energized cables. The LanRoamer™ may be damaged.

Caution!

Improperly crimped or un-crimped plugs can damage the jacks on the LanRoamer™. Inspect plugs for proper termination and crimping before inserting into the tester. Contacts should always be recessed into the plastic grooves of the plug.

Introduction

The LanRoamer™ cable tester is a unique blend of a popular type of low-end tester interface with an advanced microprocessor controller. The most popular aspects of this type of tester are an indication at both ends that the cable has been tested, no buttons to push to perform a test and a case that snaps together for storage. The microprocessor brings the additional features of automatic power management, split pair error detection, direct indication of the type and location of faults and tone generation. The patented split pair detection technique allows the LanRoamer™ to have these advanced features at a reasonable price.

Features

- Auto-on and auto-off when testing cables, just plug both ends into tester!
- Cable test results displayed on main unit and remote unit, in less than 2 seconds after plugging in the cable
- Snap-together case for easy storage and convenient patch cable testing
- Tone generator mode for use with tone tracers, auto-off
- Debug mode with from/to and failures for each pair
- Battery low indicator
- Tests for shorts, opens, miswires, reversals and split pairs

Description

The main unit has four green pair lights, a green shield light, four red fault lights, a red battery low light and a green tone light. The remote unit has four amber pair lights. When a connection from the main unit to the remote is sensed, testing begins automatically. On the main unit, the lights for each pair will either be ON, OFF or FLASHING. An ON light indicates a good pair, an OFF light indicates an open pair and a FLASHING light indicates a bad pair. If a pair is bad, one or more of the fault lights will be flashing to indicate the type or types of faults. On the remote unit, the pair lights are either ON or OFF. An ON light indicates a good pair, and an OFF light indicates an open or bad pair. Holding down the tone button until all lights momentarily turn on starts the debug mode. The pairs are stepped through one at a time to display connection and fault information on a pair-by-pair basis. A second press of the tone button turns off debug or completion of two complete cycles. When not in debug mode, pressing and releasing the tone button in less than 1.5 seconds causes the LanRoamer™ to generate a warble tone signal on all pairs, flashing the tone light to indicate tone is on. The tone will turn off automatically after three hours, or with a second press of the tone button.

Instructions for Use

LanRoamer™ powers off automatically after 5 minutes of continuously testing a cable. Disconnecting the cable restores normal function. Be sure to install a battery if using for the first time—see battery installation.

To Test a Patch Cable

- 1) Plug one end of patch cable into main unit.
- 2) Plug other end of cable into remote unit.
- 3) The tester will power on immediately, indicating a test in progress by quickly winking the pair lights on both the main and remote; it will then be followed by a combination of pair lights on — this shows the test results. See Main Unit Results and Remote Unit Results sections on page 7.
- 4) Disconnect patch cable after test. The test repeats automatically every 2.3 seconds if the cable has only open and passing pairs and repeats every 4 seconds if there are failures.

To Test Installed Cable (Office jack to patch panel)

- 1) Remove remote unit from main unit by sliding remote towards top of the main unit.
- 2) Attach one end of supplied one foot jumper cable to remote and other end to wall jack.
- 3) Attach one end of the second supplied one-foot jumper to main unit and the other end to the patch panel jack.
- 4) The tester will power on immediately, indicating a test in progress by quickly winking the pair lights on both the main and remote; it will be immediately followed by a combination of pair lights on — this shows the test results. See Main Unit Results and Remote Unit Results sections on page 7.
- 5) Disconnect after test. The test repeats automatically every 2.3 seconds if the cable has only open and passing pairs and repeats every 4 seconds if there are failures.

Application Hints: *The jumper cables must be short compared to the cable run for accurate split pair indication, no more than 10% of the total run length.*

To Test Coax (Requires optional RJ45-to-coax adapter)

- 1) Plug the RJ45 to F coax adapters into the remote and main units.
- 2) Attach cable to be tested to F connectors.
- 3) The tester will power on if it senses the cable. If not, the cable is open. The coax adapter is connected to the 1-2 pair and will be on steady if good, or blink the 1-2 and short lights if shorted.

To Place Tone on a Cable

- 1) Press and release the TONE button. The light immediately above the button will start flashing.
- 2) Connect cable to be traced to main unit. For best signal, do not connect remote. Due to the shielding effect of twisted pairs, the strongest signal is obtained by connecting only one wire in a cable to the tone source.
- 3) To turn tone off, press the TONE button a second time. The tone will turn off automatically after 3 hours.

Interpreting Results

Definition of Errors – (See “Examples of Wiring Errors”) The four fault lights are discussed below in order of severity. The severity has to do with the ability of the type of error to mask lower severity errors. For example, if there is a short in the cable, miswires, reversals and split pairs cannot be detected for the pairs involved in the short fault. Multiple faults on multiple pairs can be better understood by using the debug mode to examine the errors one pair at a time.

Short – The pair has a low resistance connection from one wire of the pair to the other wire of the pair or to any other wire in the cable or the shield. A single flashing pair light and the short light indicate a short within the pair. Multiple flashing pair lights and only the short light indicate shorts between the pairs involved.

Miswire – A wire or both wires of a pair are not connected to the correct pins at the other end of the cable. Debugs “from-to” format is very helpful in visualizing what the specific miswire is.

Reverse – A reverse is a special case of a miswire in which the pair is wired to the correct pair of pins or to another designated pair of pins, but the two leads are reversed.

Split Pair – A split pair is an error in the twisting of the wires together within the cable. The cables generally are made up of eight wires twisted together in 4 pairs. These 4 pairs are designated as pairs by the wiring standards and are intended to carry a signal and its return. 1 & 2, 3 & 6, 4 & 5 and 7 & 8 are the pairs designated by T568A/B. A cable can be wired with correct continuity, but not with correct pairing. This most often happens when the cable is terminated consistently at both ends, but in the wrong order. A dynamic or AC test is required to detect this type of error. If the only error is a split pair error, the cable has correct continuity. If cross talk is not a concern, as in flat satin cable, the cable is good if the only error is the split pair error.

Examples of Wiring Errors

○ = OFF
 ● = ON
 ☀ = FLASH

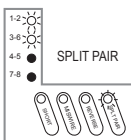
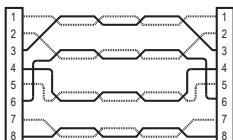
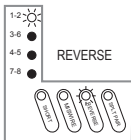
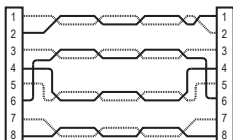
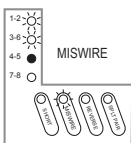
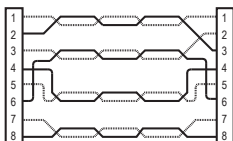
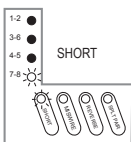
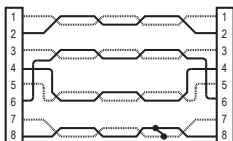
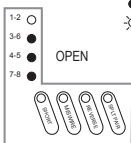
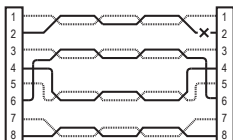

(1 not twisted with 2; 3 not twisted with 6)

Main Unit Results – The main unit indicates the beginning of a test by flashing the pair lights in sequence top to bottom. The cable is then tested and the results displayed as follows:

Pair light off – Pair is open. Depending on the wiring standard, this may be correct.

Pair light on – Pair is wired correctly.

Pair light is flashing – One or more errors were detected for this pair, as indicated by flashing error lights.

If there are no flashing lights, the results are displayed for 2 seconds. If there was an error, the results are displayed for twice as long.

Remote Unit Results – The remote unit indicates the beginning of a test by flashing the pair lights quickly, the order or number of lights flashed depends on the cable being tested.

The cable is then tested and the results displayed as follows:

Pair light off – Pair is open or has a fault. Depending on the wiring standard, this may be correct.

Pair light on – Pair is wired correctly.

If there are no errors, the results are displayed for 2 seconds.

If there was an error, the results are displayed for twice as long.

If the lights for the pairs expected are on, the cable is good.

Debug Mode – (See “Ethernet Up-Link Cable Example”) The debug mode is provided to allow diagnosis of faults, especially when there are multiple errors on multiple pairs. To enter the debug mode, press and hold the tone button until all lights on the main unit light (lamp test). Once the lamp test is complete, debug displays the results of the last cable test. This is from internal memory, so the cable is not required to be connected when running debug.

The debug display begins with a short flash on the 1-2 pair to indicate that what follows is the result for the 1-2 pair test (or the “from”). If the pair was not open, a second longer flash on one or more pair lights designates what pair 1-2 is connected “to” at the remote end, or pairs involved in a fault condition along with the fault lights. The 3-6, 4-5 and 7-8 pair lights each in turn begin with a short flash followed by the results for that pair. The individual pair results continue to be displayed until the tone button is pressed again or two complete cycles of all pairs is completed. The remote unit does not display anything when in debug mode.

Ethernet Up-Link Cable Example

1-2 and 3-6 swapped

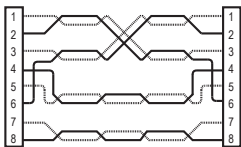

Wiring Diagram

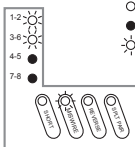

Cable Test Results

○ = OFF
● = ON
☀ = FLASH

Sequence of LanRoamer™ debug mode displays for Ethernet up-link cable

Short Flash

Long Flash

1-2

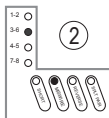
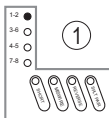

Pair connected from
1-2 to 3-6 (miswire)

3-6

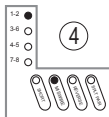
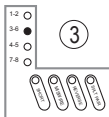

Pair connected from
3-6 to 1-2 (miswire)

4-5

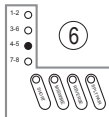
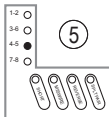

Pair connected from
4-5 to 4-5 (good)

7-8

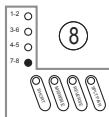
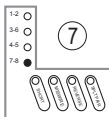

Pair connected from
7-8 to 7-8 (good)

Battery Replacement

When the battery low light is on while generating tone or testing cables, the battery should be replaced as soon as practical. The cable testing results will become unreliable when the battery reaches about 4.5 volts.

To replace battery:

- 1) Remove rubber battery cap by peeling back a corner until it pops off.
- 2) Pull battery out of cavity and remove battery snap.
- 3) Connect a new Alkaline 9 volt battery to battery snaps.
- 4) Slide battery into cavity and snap cap in place.

Specifications

Electrical

Battery Life, typical alkaline — times are for the full capacity of the battery used continuously in one of the following modes —Standby: 2.5 years

Cable Testing: 20 hours

Tone Mode: 170 hours

Cable Types: Shielded or unshielded, CAT3, CAT4, CAT5, CAT5e, CAT6

Minimum cable length for testing split pairs:
1 meter (3 feet)

Maximum cable length for testing:
305 meters (1000 feet)

Coax Cable: 100 ohms maximum DC resistance,
center conductor plus shield

Environmental

Temperature

Operating: 0 to 50°C (32 to 122°F)

Storage: -20 to 70°C (-4 to 158°F)

Humidity: 10% to 90%, non-condensing

Physical

Length: 14.5 cm (5.70 in)

Width: 7.2 cm (2.85 in)

Height: 3.0 cm (1.20 in)

Weight (with battery): 162 gm (5.7 oz.)

(Specifications subject to change)

Warranty

JDSU guarantees that its products will be free of all defects in material and workmanship. This warranty extends for the period of 12 months for test instruments and 3 months for cables from date of manufacture or purchase (proof of purchase required).

All product deemed defective under this warranty will be repaired or replaced at JDSU's discretion. No further warranties either implied or expressed will apply, nor will responsibility for operation of this device be assumed by JDSU.



WEEE Directive Compliance: JDSU has established processes in compliance with the Waste Electrical and Electronic Equipment (WEEE) Directive, 2002/96/EC. This product should not be disposed of as unsorted municipal waste and should be collected separately and disposed of according to your national regulations. In the European Union, all equipment purchased from JDSU after 2005-08-13 can be returned for disposal at the end of its useful life. JDSU will ensure that all waste equipment returned is reused, recycled, or disposed of in an environmentally friendly manner, and in compliance with all applicable national and international waste legislation. It

is the responsibility of the equipment owner to return the equipment to JDSU for appropriate disposal. If the equipment was imported by a reseller whose name or logo is marked on the equipment, then the owner should return the equipment directly to the reseller. Instructions for returning waste equipment to JDSU can be found in the Environmental section of JDSU's web site at www.jdsu.com. If you have questions concerning disposal of your equipment, contact JDSU's WEEE Program Management team at WEEE.EMEA@jdsu.com.

Shipping

Before returning any product to JDSU, you must first request a Return Merchandise Authorization Number by contacting our Customer Service Dept. at (805) 383-1500.

- 1) No shipments will be accepted without this number, which must be clearly marked on the shipping label.
- 2) Ship the equipment with a copy of the sales receipt, if available.
- 3) Attach a description of the operational problem.
- 4) Include a contact name, phone number and E-mail address.
- 5) Pack securely to prevent damage during shipping.
- 6) Ship prepaid to: JDSU, 808 Calle Plano, Camarillo, CA 93012

Support Service

For technical information and support, please visit www.jdsu.com/hbn.

Notes:

Notes:

Contact Information:

**Test Equipment
Depot**



1-800-517-8431

99 Washington Street
Melrose, MA 02176
Phone 781-665-1400
Toll Free 1-800-517-8431



Visit us at www.TestEquipmentDepot.com

