

User Manual



Tektronix

SPG600 & SPG300 Sync Pulse Generators

071-1340-00

This document supports firmware version 1.00 and above.

Table of Contents

Preface	ix
About This Manual	ix
Related Manuals	ix

Getting Started

Getting Started	1-1
Product Description	1-1
Initial Product Inspection	1-2
Installation	1-3
Repackaging for Shipment	1-4
Functional Check Procedure	1-5
Standard Accessories	1-10
Optional Accessories	1-12
Options	1-12

Operating Basics

Operating Basics	2-1
Front-panel Buttons and Indicators	2-1
Rear-Panel Connectors	2-3

Reference

Menus	3-1
Video Menu	3-2
Audio Menu	3-17
Genlock Menu	3-23
System Menu	3-26
Using the General Purpose Interface (GPI)	3-41
GPI Connector Pin Assignments	3-41
Recalling a Preset	3-42
Outputting an Alarm Signal	3-43
Factory Default Settings	3-45

Appendices

Appendix A: Specifications	A-1
General Characteristics	A-1
Certifications and Compliances	A-10
Appendix B: Using the Remote Interface	B-1
Using a Web Browser	B-1
Using the Java Applet for the Remote Interface	B-3

Appendix C: Using Logo Generator	C-1
PC System Requirement	C-1
Installation Instructions	C-1
Starting and Exiting Logo Generator	C-3
Elements of the Logo Generator Window	C-4
Using the Logo Generator Menus	C-6
Logo Generator Tutorials	C-9
Appendix D: Rackmounting the Instrument (SPG600 Option 1R Only)	D-1
Minimum Tool and Equipment List	D-1
Installation Instructions	D-2
Appendix E: User Maintenance	E-1
Cleaning	E-1
Preventive Maintenance	E-1

Index

List of Figures

Figure 2-1: SPG600 front panel	2-1
Figure 2-2: SPG300 front panel	2-1
Figure 2-3: SPG600 rear panel (Option 0203)	2-3
Figure 2-4: SPG300 rear panel	2-3
Figure 3-1: Example menu display	3-1
Figure 3-2: Video menu diagram	3-3
Figure 3-3: Test signal (analog) submenu diagram	3-6
Figure 3-4: Test signal (SDI) submenu diagram	3-9
Figure 3-5: Timing (analog) submenu diagram	3-11
Figure 3-6: Timing (SDI) submenu diagram	3-12
Figure 3-7: Overlay submenu diagram	3-13
Figure 3-8: Logo submenu diagram	3-14
Figure 3-9: ID text submenu diagram	3-15
Figure 3-10: SDI parameters submenu diagram	3-16
Figure 3-11: Audio menu diagram	3-17
Figure 3-12: AES/EBU submenu diagram	3-19
Figure 3-13: Embedded submenu diagram	3-20
Figure 3-14: Audio channel submenu diagram	3-21
Figure 3-15: Genlock menu diagram	3-23
Figure 3-16: Genlock timing submenu diagram	3-25
Figure 3-17: System menu diagram	3-26
Figure 3-18: Preset submenu diagram	3-28
Figure 3-19: Network information submenu diagram	3-30
Figure 3-20: Network setup submenu diagram	3-31
Figure 3-21: GPI submenu diagram	3-34
Figure 3-22: System information submenu diagram	3-35
Figure 3-23: System setup submenu diagram	3-36
Figure 3-24: Configuration submenu diagram	3-37
Figure 3-25: Pin assignments of the GPI Connector	3-41
Figure 3-26: Input/output circuit of GPI	3-42
Figure A-1: SPG600 dimensions	A-7
Figure A-2: SPG300 dimensions	A-8

Figure B-1: Accessing the remote interface using a Web browser	B-2
Figure B-2: Java applet	B-4
Figure B-3: Java applet window	B-5
Figure B-4: Java applet window after selecting the Genlock tab	B-7
Figure B-5: File Transfer setting panel	B-8
Figure B-6: Select Logo Folder dialog box	B-9
Figure C-1: Logo Generator application window	C-4
Figure C-2: Gray Scale Settings dialog box	C-7
Figure C-3: Miscellaneous Settings dialog box	C-8
Figure C-4: BMP to LGO File Conversion dialog box	C-9
Figure D-1: Assembly of slide-out track assemblies (right slide-out track)	D-3
Figure D-2: Installation of slide-out track assemblies in rack (top view)	D-4

List of Tables

Table 1-1: Output capability between the SPG600 and the SPG300	1-2
Table 1-2: AC line power requirement	1-3
Table 1-3: Power cord identification	1-11
Table 3-1: Instrument menus and information pages	3-1
Table 3-2: Selectable signals in each signal set (analog)	3-7
Table 3-3: Selectable signals in each signal set (SDI)	3-10
Table 3-4: Analog output timing range	3-12
Table 3-5: SDI output timing range	3-13
Table 3-6: Genlock timing range	3-25
Table 3-7: Combinations of signal levels and the corresponding preset	3-42
Table 3-8: Factory default settings	3-45
Table A-1: Reference Inputs	A-2
Table A-2: Analog outputs (standard and Option 02)	A-2
Table A-3: Serial digital interface (standard and Option 03)	A-3
Table A-4: AES/EBU audio outputs	A-4
Table A-5: Analog audio outputs	A-5
Table A-6: GPI (general purpose interface)	A-5
Table A-7: SNMP error report	A-5
Table A-8: AC power source	A-6
Table A-9: Clearance	A-6
Table A-10: Mechanical characteristics	A-6
Table A-11: Environment characteristics	A-9
Table A-12: Certifications and compliances	A-10
Table B-1: Web browser interface functions	B-2
Table B-2: Remote Interface menu	B-6
Table C-1: Elements of the Logo Generator window	C-5
Table C-2: Toolbar button description	C-5
Table C-3: File menu commands	C-6
Table C-4: Build menu command	C-6
Table C-5: Setting menu commands	C-6

Table C-6: Help menu command C-8

Table D-1: Tools required for rackmount installation D-1

General Safety Summary

Review the following safety precautions to avoid injury and prevent damage to this product or any products connected to it. To avoid potential hazards, use this product only as specified.

Only qualified personnel should perform service procedures.

To Avoid Fire or Personal Injury

Use Proper Power Cord. Use only the power cord specified for this product and certified for the country of use.

Ground the Product. This product is grounded through the grounding conductor of the power cord. To avoid electric shock, the grounding conductor must be connected to earth ground. Before making connections to the input or output terminals of the product, ensure that the product is properly grounded.

Observe All Terminal Ratings. To avoid fire or shock hazard, observe all ratings and markings on the product. Consult the product manual for further ratings information before making connections to the product.

Do Not Operate Without Covers. Do not operate this product with covers or panels removed.

Avoid Exposed Circuitry. Do not touch exposed connections and components when power is present.

Do Not Operate With Suspected Failures. If you suspect there is damage to this product, have it inspected by qualified service personnel.

Do Not Operate in Wet/Damp Conditions.

Do Not Operate in an Explosive Atmosphere.

Keep Product Surfaces Clean and Dry.

Provide Proper Ventilation. Refer to the manual's installation instructions for details on installing the product so it has proper ventilation.

No Power Switch. Power supply cord is considered the disconnecting device, disconnect the main power by means of the power cord.

Symbols and Terms **Terms in this Manual.** These terms may appear in this manual:



WARNING. *Warning statements identify conditions or practices that could result in injury or loss of life.*



CAUTION. *Caution statements identify conditions or practices that could result in damage to this product or other property.*

Terms on the Product. These terms may appear on the product:

DANGER indicates an injury hazard immediately accessible as you read the marking.

WARNING indicates an injury hazard not immediately accessible as you read the marking.

CAUTION indicates a hazard to property including the product.

Symbols on the Product. The following symbols may appear on the product:



DANGER
High Voltage



Protective Ground
(Earth) Terminal



ATTENTION
Refer to Manual

Preface

This manual describes the capabilities, features, and specifications of the SPG600 and SPG300 Sync Pulse Generators.

About This Manual

This manual is provided as an Adobe PDF document. An optional printed version of this user manual is available from Tektronix (see page 1-12).

This manual contains the following sections:

- *Getting Started* provides a product description, installation instructions, and a functional check procedure. Standard and optional accessories are also listed.
- *Operating Basics* briefly describes the front-panel controls and rear-panel connections.
- *Reference* provides detailed information about the sync pulse generator menu functions.
- *Appendices* contains reference information such as specifications, instructions for operating the Logo Generator application, and how to use the remote interface.

Related Manuals

The following related documents are also available:

- The *SPG600 & SPG300 Quick Reference Manual* (Tektronix part number 071-1341-XX) contains information to enable you to quickly get an overview of front-panel buttons, rear-panel connectors, and menus.
- The *SPG600 & SPG300 Service Manual* (Tektronix part number 071-1342-XX) is an optional accessory that provides module-level service information and a complete performance verification procedure.



Getting Started

Getting Started

This section contains the following information:

- Product description
- Initial product inspection procedure
- Installation instructions
- Instructions for repackaging the instrument for shipment
- Functional check procedure
- Standard and optional accessories
- Options

Product Description

The SPG600 and SPG300 Sync Pulse Generators are designed for high stability master sync operation. The sync pulse generators provide a wide range of accurate reference signals including analog video, analog black burst, serial digital video, serial digital black, and AES/EBU digital audio.

Key Features

The sync pulse generator features includes:

- High stability internal reference
- Genlocks to the following signals:
 - NTSC/PAL black burst signal
 - 1, 5, 10 MHz, and NTSC/PAL Fsc CW signals
- Serial digital video signal outputs
- AES/EBU serial digital audio outputs (XLR and BNC)
- Overlay a logo or ID text on the color bars or test signal
- Up to 16 channels of embedded audio
- 48 kHz word clock output
- GPI (general purpose interface) for error status report and user preset
- Ethernet (100 BASE-T) interface remote control

Table 1-1: Output capability between the SPG600 and the SPG300

Signal	SPG600 outputs			SPG300 outputs
	Standard	Option 02	Option 03	
Serial digital				
Video	2	2	4	2
BNC audio	4	4	4	None
XLR audio	2	2	2	2*
Analog video	4	8	4	4
48 kHz word clock	Yes	Yes	Yes	Yes

* The SPG300 XLR outputs can be set to either serial digital or analog audio ports.

NOTE. Refer to Operating Basics beginning on page 2-1 for detailed information about the rear-panel connectors.

Initial Product Inspection

Perform the following product inspection procedure when you initially receive your instrument:

1. Inspect the shipping carton for external damage, which indicates possible damage to the instrument.
2. Remove the sync pulse generator from the shipping carton.
3. Check that the instrument has not been damaged in transit. The exterior should not have any scratches or impact marks. Prior to shipment the instrument is thoroughly inspected for mechanical defects.

NOTE. Save the shipping carton and packaging materials for instrument repackaging in case shipment becomes necessary.

4. Verify that the shipping carton contains the instrument, the standard accessories, and any optional accessories that you ordered.
5. Perform the functional check procedure (refer to *Functional Check Procedure* on page 1-5) after installing the instrument.

Installation

Before you install the instrument, refer to the *General Safety Summary* section at the front of this manual for power source, grounding, and other safety information.



WARNING. Do not use the rack handles to carry the SPG600. The rack handles are not designed for this purpose, and property damage or injury may result.

Rackmount Installation

You can install the sync pulse generator into an equipment rack if you ordered Option 1R. For information on how to install the sync pulse generator into the rack, refer to *Appendix D: Rackmounting the Instrument (Option 1R Only)*.

Environment Operating Requirements

Verify that the location of your installation has the proper operating environment.



CAUTION. Damage to the instrument can occur if this instrument is powered on at temperatures outside of the specified temperature range.

The sync pulse generator operates correctly in ambient temperatures from 0 °C to +40 °C and relative humidity from 20% to 80%. For complete operating environment information, refer to *Appendix A: Specifications*.

The sync pulse generator requires 2 inches (5 cm) of side clearance for counter top use. Also, ensure sufficient rear clearance (approximately 3 inches) so that cables are not damaged.

Connecting Power

The sync pulse generator operates from a single-phase power source with the neutral conductor at or near earth ground. The line conductor is fused for over-current protection. A protective ground connection through the grounding conductor in the power cord is essential for safe operation.



CAUTION. The instrument does not have a power switch. When you connect the power cable to the AC line connector, the instrument powers on.

AC Power Requirement. Check that your location provides the proper electrical power requirements as listed in Table 1-2.

Table 1-2: AC line power requirement

Parameter	Description
Line voltage range	90 to 250 V
Line frequency	50/60 Hz
Maximum power	SPG600: 85 VA (35 W) SPG300: 65 VA (30 W)

Connecting the Power Cable. Connect the power cable to the instrument first, and then connect it to the AC power source. Note that connecting the power cable causes the instrument to power on.

After connecting the power, make sure that the fan inside the instrument is working. If the fan is not working, turn off the power by disconnecting the power cable from the AC power source and contact your local Tektronix Field Office or representative.

Repackaging for Shipment

When you ship this instrument, use the original packaging material if possible. If the original packaging is unfit for use or is not available, repackage the instrument using the following procedure:

1. Obtain a corrugated cardboard shipping carton having inside dimensions at least six inches greater than the instrument dimensions and having a carton test strength of at least 125 kg (275 pounds).
2. If the instrument is being shipped to a Fotronic Service Center for repair or calibration, attach a tag to the instrument showing the following information:
 - The owner of the instrument (with address).
 - The name of a person at your company who may be contacted if additional information is needed.
 - The complete instrument type and serial number.
 - A description of the service required.
3. Wrap the instrument with polyethylene sheeting or equivalent to protect the outside finish and prevent entry of packing materials into the instrument.
4. Cushion the instrument on all sides by tightly packing dunnage or urethane foam between the carton and the instrument, allowing for three inches (7.62 cm) of padding on each side (including top and bottom).
5. Seal the carton with shipping tape or with an industrial stapler.

Functional Check Procedure

Perform the following procedure if you are operating the instrument for the first time (to verify that the instrument shipped without damage) or you suspect that the instrument is not working properly:

NOTE. Before you perform this procedure, install the sync pulse generator following the instructions listed in Installation starting on page 1-3.

Required Equipment

The following equipment is required for the functional check:

- TV signal generator
- Waveform monitor
- Digital audio monitor
- Audio analyzer
- 75 Ω BNC cable
- XLR cable
- 75 Ω termination

Procedure

1. Power on the sync pulse generator by connecting it to the power source. The instrument runs its power-on initialization process.
2. Check that no error messages appear on the LCD display.
3. Let the instrument run for 20 minutes before doing the rest of the functional check procedure.

Genlock Function.

4. Press the **GENLOCK** button to display the Genlock menu.
5. Press the up (**▲**) or down (**▼**) arrow button to select **GENLOCK SOURCE**.
6. Press the left (**◀**) or right (**▶**) arrow button to select **Internal**.
7. Press the **ENTER** button.
8. Check that the **INT REF** indicator lights. This shows that the instrument is using the internal reference signal.
9. Using a 75 Ω BNC cable, connect the TV signal generator output to the sync pulse generator **REF** connector. Terminate the unused **REF** connector with the 75 Ω termination.

10. Press the left (◀) or right (▶) arrow button to select the menu item corresponding to the input signal type (for example, **NTSC Burst**).
11. Press the **ENTER** button.
12. Check that the **EXT REF** indicator lights. This shows that the instrument is locked to the input signal.
13. Disconnect the BNC cable from the **REF** connector.
14. Check that the **EXT REF** indicator blinks. This shows that the sync pulse generator detects when an incorrect or missing reference signal is applied to the REF connector.

Signal Outputs (Standard).

15. Press the **SYSTEM** button to enter the System menu.
16. Press the up (▲) or down (▼) arrow button to select **CONFIGURATION**.
17. Press the **ENTER** button. This enters the Configuration submenu.
18. Press the left (◀) or right (▶) arrow button to select a video standard (**NTSC** or **PAL**) for your waveform monitor and then press the **ENTER** button.
19. Press the up (▲) or down (▼) arrow button to select **ANALOG OUTPUT (STD)**.
20. Press the left (◀) or right (▶) arrow button to select **BB: 1,2,3 TEST: 4**.
21. Press the **ENTER** button.
22. Press the up (▲) or down (▼) arrow button to select **SDI OUTPUT (STD)**.
23. Press the left (◀) or right (▶) arrow button to select **BLACK: 1 TEST: 2**.
24. Press the **ENTER** button.
25. Press the **VIDEO** button to enter the Video menu.
26. Press the up (▲) or down (▼) arrow button to select **TEST SIGNAL (ANALOG)**.
27. Press the left (◀) or right (▶) arrow button to select **Standard**.
28. Press the **ENTER** button.
29. Press the up (▲) or down (▼) arrow button to select **COLOR BAR**.
30. Press the left (◀) or right (▶) arrow button to select **100% Color Bars**.
31. Press the **CANCEL** button.

32. Press the up (▲) or down (▼) arrow button to select **TEST SIGNAL (SDI)**.
33. Press the left (◀) or right (▶) arrow button to select **Standard**.
34. Press the **ENTER** button.
35. Press the up (▲) or down (▼) arrow button to select **COLOR BAR**.
36. Press the left (◀) or right (▶) arrow button to select **100% Color Bars**.
37. Connect the sync pulse generator **CH 1** connector to the waveform monitor using the 75 Ω BNC cable.
38. Set the waveform monitor to view the black burst signal.
39. Check that the waveform monitor displays the appropriate black burst signal.
40. Change the BNC cable from the **CH 1** connector to the **CH 2** connector.
41. Check that the waveform monitor displays the appropriate black burst signal.
42. Change the BNC cable from the **CH 2** connector to the **CH 3** connector.
43. Check that the waveform monitor displays the appropriate black burst signal.
44. Change the BNC cable from the **CH 3** connector to the **CH 4** connector.
45. Set the waveform monitor to view the color bars signal.
46. Check that the waveform monitor displays the appropriate color bars signal.
47. Change the BNC cable from the **CH 4** connector to the **SDI 1** connector.
48. Check that the waveform monitor displays the appropriate black burst signal.
49. Change the BNC cable from the **SDI 1** connector to the **SDI 2** connector.
50. Check that the waveform monitor displays the appropriate color bars signal.

Signal Outputs (SPG600 Option 02 Only).

51. Perform steps 15 through 17.
52. Press the up (▲) or down (▼) arrow button to select **ANALOG OUTPUT (OPT)**.
53. Press the left (◀) or right (▶) arrow button to select **BB: 5,6,7 TEST: 8** and then press the **ENTER** button.
54. Press the **VIDEO** button to enter the Video menu.
55. Press the up (▲) or down (▼) arrow button to select **TEST SIGNAL (ANALOG)**.

56. Press the left (◀) or right (▶) arrow button to select **Option** and then press the **ENTER** button.
57. Press the up (▲) or down (▼) arrow button to select **COLOR BAR**.
58. Press the left (◀) or right (▶) arrow button to select **100% Color Bars**.
59. Connect the **CH 5** connector to the waveform monitor using the 75 Ω BNC cable.
60. Set the waveform monitor to view the black burst signal.
61. Check that the waveform monitor displays the appropriate black burst signal.
62. Change the BNC cable from the **CH 5** connector to the **CH 6** connector.
63. Check that the waveform monitor displays the appropriate black burst signal.
64. Change the BNC cable from the **CH 6** connector to the **CH 7** connector.
65. Check that the waveform monitor displays the appropriate black burst signal.
66. Change the BNC cable from the **CH 7** connector to the **CH 8** connector.
67. Set the waveform monitor to view the color bars signal.
68. Check that the waveform monitor displays the appropriate color bars signal.

Signal Outputs (SPG600 Option 03 Only).

69. Perform steps 15 through 17.
70. Press the up (▲) or down (▼) arrow button to select **SDI OUTPUT (OPT)**.
71. Press the left (◀) or right (▶) arrow button to select **BLACK: 3 TEST: 4** and then press the **ENTER** button.
72. Press the **VIDEO** button to enter the Video menu.
73. Press the up (▲) or down (▼) arrow button to select **TEST SIGNAL (SDI)**.
74. Press the left (◀) or right (▶) arrow button to select **Option** and then press the **ENTER** button.
75. Press the up (▲) or down (▼) arrow button to select **COLOR BAR**.
76. Press the left (◀) or right (▶) arrow button to select **100% Color Bars**.
77. Connect the **SDI 3** connector to the waveform monitor using the 75 Ω BNC cable.
78. Check that the waveform monitor displays the appropriate black burst signal.
79. Change the BNC cable from the **SDI 3** connector to the **SDI 4** connector.

80. Check that the waveform monitor displays the appropriate color bars signal.

AES/EBU Audio Outputs.

81. Press the **SYSTEM** button to enter the System menu.

82. Press the up (▲) or down (▼) arrow button to select **CONFIGURATION** and then press the **ENTER** button. This enters the Configuration submenu.

83. Press the up (▲) or down (▼) arrow button to select **XLR OUTPUT**.

84. Press the left (◀) or right (▶) arrow button to select **AES/EBU Audio**.

85. Press the **ENTER** button.

86. Connect the **1+2/RIGHT** XLR connector to the digital audio monitor using the XLR cable.

87. Set the digital audio monitor to display the status for the audio data, and to receive a signal through the XLR-balanced input.

88. Check that the monitor does not show any CRC error.

89. Change the XLR cable from the **1+2/RIGHT** XLR connector to the **3+4/LEFT** XLR connector.

90. Check that the monitor does not show any CRC error.

91. Disconnect the XLR cable from the **3+4/LEFT** XLR connector.

SPG600 Only:

92. Connect the **AES 1+2** connector to the digital audio monitor using the 75 Ω BNC cable.

93. Set the digital audio monitor to receive a signal through the BNC-unbalanced input.

94. Check that the monitor does not show any CRC error.

95. Change the BNC cable from **AES 1+2** connector to the **AES 3+4** connector.

96. Check that no CRC errors appear on the monitor.

97. Change the BNC cable from **AES 3+4** connector to the **AES 5+6** connector

98. Check that no CRC errors appear on the monitor.

99. Change the BNC cable from **AES 5+6** connector to the **AES 7+8** connector

100. Check that no CRC errors appear on the monitor.

Analog Audio Outputs.

- 101.** Press the left (◀) or right (▶) arrow button to select **Analog Audio**.
- 102.** Press the **ENTER** button.
- 103.** Connect the **1+2/RIGHT** XLR connector to the audio analyzer input using the XLR cable.
- 104.** Check that the audio signal output from the connector is correct.
- 105.** Move the XLR cable from the **1+2/RIGHT** XLR connector to the **3+4/LEFT** XLR connector.
- 106.** Check that the audio signal output from the connector is correct.

Standard Accessories

The following accessories are shipped with the sync pulse generator:

Documents and CD-ROM

The following documents and CD-ROM are standard accessories:

- *SPG 600 & SPG300 Sync Pulse Generators Quick Reference Manual*, Tektronix part number 071-1341-XX.
- *SPG600 & SPG300 Sync Pulse Generators Application Software CD-ROM*, Tektronix part number 063-3685-XX. This CD-ROM contains signal files, the Logo Generator application software, and the PDF version of the SPG600 & SPG300 User Manual.

For detailed information about Logo Generator and how to use it, refer to *Appendix C: Using Logo Generator*.

Power Cords All SPG600 & SPG300 Sync Pulse Generators are shipped with one of the following power cord options. Power codes for use in North America are UL listed and CSA certified. Cords for use in areas other than North America are approved by at least one authority acceptable in the country to which the product is shipped.

Table 1-3: Power cord identification

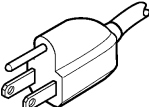
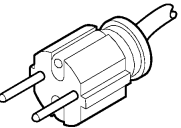
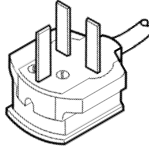
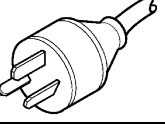
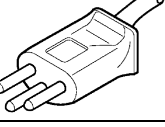
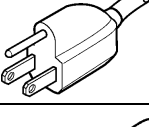
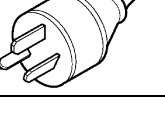
Plug configuration	Normal usage	Option number
	North America 115 V	Standard (A0)
	Universal Euro 220 V	A1
	United Kingdom 240 V	A2
	Australia 240 V	A3
	Switzerland 240V	A5
	Japan 100 V	A6
	China 240 V	A10
-----	Argentina (no power code shipped with the instrument)	A99

Optional Accessories

You can order the following optional accessories to use with the sync pulse generators:

Documents

The following documents are optional accessories:

- *SPG600 & SPG300 Sync Pulse Generators User Manual* (printed manual), Tektronix part number 071-1340-XX
- *SPG600 & SPG300 Sync Pulse Generators Service Manual*, Tektronix part number 071-1342-XX

Rackmounting Kits (SPG300 Only)

The following rackmounting kits are optional accessories for the SPG300:

- **TVGF11A**: Rackmounts a single instrument in a standard 19-inch rack.
- **TVGF13**: Rackmounts two half-rack width instruments side-by-side in a standard 19-inch rack.

Options

The sync pulse generator can be ordered with the following instrument options:

Rackmount (SPG600 Only)

The following rackmount option is available for the SPG600:

- **Option 1R**: Adds the hardware to install the instrument into a standard 19-inch rack.

Additional Features

You can add fine timing offset, analog outputs, and serial digital outputs.

- **Option 01** (SPG600 and SPG300): Adds fine timing offset for analog outputs.
- **Option 02** (SPG600 only): Adds four channel analog video outputs.
- **Option 03** (SPG600 only): Adds two channel SD-SDI video outputs.

Service Options

The following service options are available for the sync pulse generator:

- **Option D1**: Provides calibration data.
- **Option D3**: Provides calibration data for 3 years.
- **Option D5**: Provides calibration data for 5 years.
- **Option C3**: Provides calibration services for 3 years.
- **Option C5**: Provides calibration services for 5 years.

- **Option R3:** Extends the instrument warranty to 3 years.
- **Option R5:** Extends the instrument warranty to 5 years.

Power Cord Options See Table 1-3 on page 1-11.



Operating Basics

Operating Basics

This section introduces you to the basics of operating the sync pulse generator. The information is divided into the following subsections:

- Front-panel buttons and indicators
- Rear panel connectors

Front-panel Buttons and Indicators

Figure 2-1 and 2-2 show the sync pulse generator front-panel button. Descriptions of the front-panel buttons and indicators appear on the following pages.

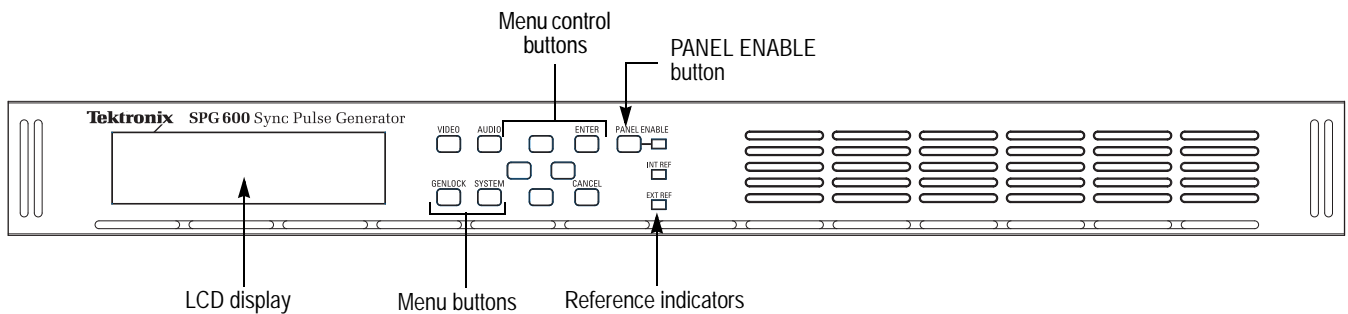

Figure 2-1: SPG600 front panel

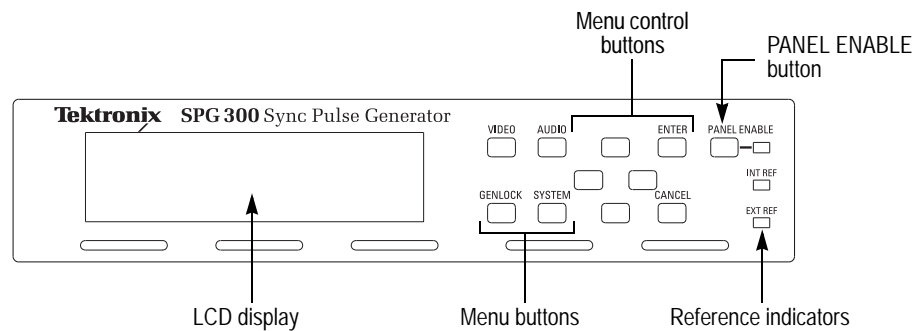

Figure 2-2: SPG300 front panel

- LCD Display** Use the two-line, 20-character-per-line LCD display to show instrument settings.
- You can adjust the contrast of the LCD display using the System menu. Refer to *System menu* on page 3-26 for detailed information about the menu.
- VIDEO Button** Use this button to access the Video menu. The Video menu lets you select an output signal and set video parameters.
- AUDIO Button** Use this button to access the Audio menu. The Audio menu lets you set audio parameters such as amplitude and frequency.
- GENLOCK Button** Use this button to access the Genlock menu. The Genlock menu lets you set genlock parameters, such as genlock source and genlock timing.
- SYSTEM Button** Use this button to access the System menu. The System menu lets you set system related parameters, such as output configuration and network parameters.
- Menu Control Buttons** Use these buttons to control the menu display. Refer to *Menus* on page 3-1 for detailed information on controlling menus.
- Arrow Buttons.** Use the arrow buttons to scroll through the available menu items.
- ENTER Button.** Use the ENTER button to enable the selected menu item.
- CANCEL Button.** Use the CANCEL button to disable the selected menu item and return to the previous menu item.
- PANEL ENABLE button** Use this button to enable or disable the front-panel buttons. When pressing this button for about one second while the front-panel buttons are enabled, all of the front-panel buttons are disabled. If you have selected a timeout period in the FRONT PANEL DISABLE item in the System menu, and that period passes without a button push, all of the front-panel buttons are also disabled.
- Press and hold this button for about three seconds to enable the front-panel buttons. The timeout counter is restarted (if the timeout period is already set) and turns the indicator next to the button lights to show that the front-panel is enabled.
- Refer to the *System* menu on page 3-26 for more information on setting the timeout period.

Reference Indicators The reference indicators indicate whether the sync pulse generator is locked to its internal oscillator or an external reference signal.

INT.REF. This indicator lights when the sync pulse generator is using its internal reference oscillator.

EXT.REF. This indicator lights when the sync pulse generator is locked to an external reference signal. A blinking indicator means that the sync pulse generator is using the external reference signal but is unable to lock to the signal.

Rear-Panel Connectors

Figure 2-3 and 2-4 show the locations of the rear panel connectors of the SPG600 and SPG300. A brief discussion of each feature follows the illustration.

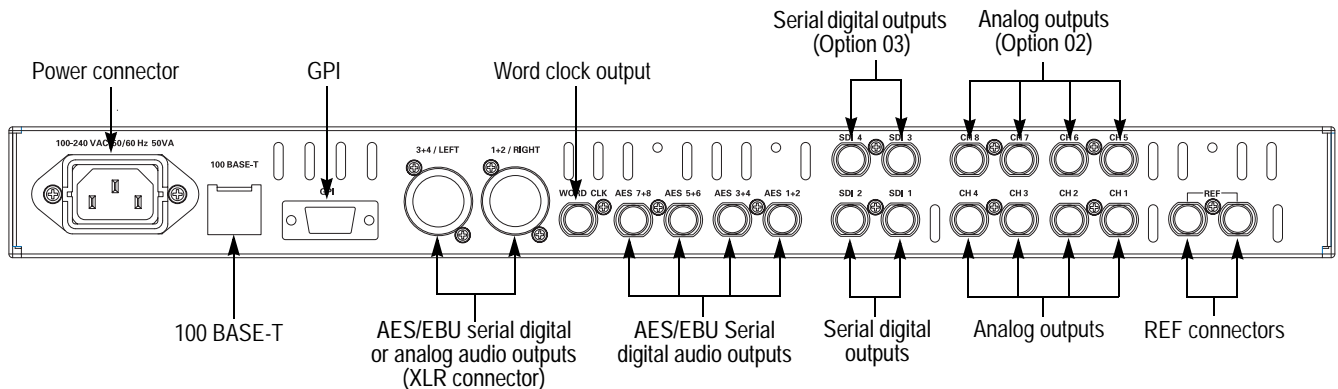

Figure 2-3: SPG600 rear panel (Option 0203)

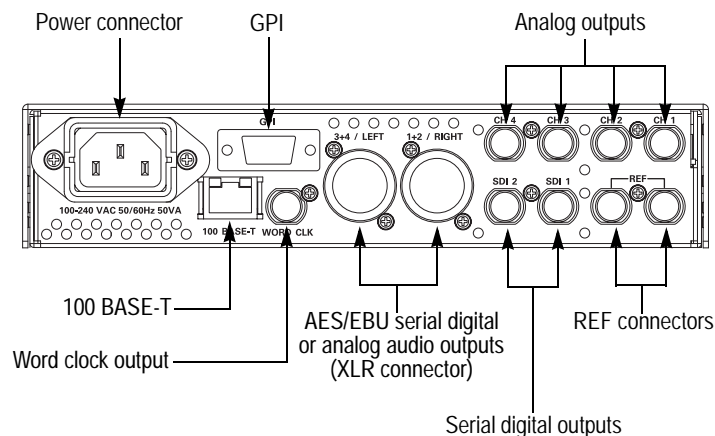

Figure 2-4: SPG300 rear panel

Power Connector The sync pulse generator is designed to operate from a single-phase power source with the neutral conductor at or near earth ground. Only the line conductor is fused for over-current protection. A protective ground connection through the grounding conductor in the power cord is essential for safe operation.



WARNING. To avoid dangerous electric shock, do not connect power to the instrument when the top cover is off. Dangerous potentials are present on the Power circuit board.

The sync pulse generator operates from an AC line frequency of 48 to 63 Hz, over the range of 85 to 250VAC, without the need for configuration. Refer to *Appendix A: Specifications* for additional information on power and environment requirements.

100 BASE-T Connect to your local Ethernet network. You can control the sync pulse generator remotely through the port. You can also upload and download signal files, logo files, and preset files through the port.

GPI (General Purpose Interface) A 9-pin subminiature D-type connector used as a ground closure interface for recalling one of the seven preset, outputting an alarm signal, and displaying an alarm status on the LCD. Refer to *Using the General Purpose Interface (GPI)* on page 3-41 for more information.

REF Loophrough connectors for an external reference signal. These inputs accept the NTSC/PAL black burst signals and CW signals. Be sure to install a 75 Ω termination on the unused connector.

CH 1, CH 2, CH 3, and CH 4 Analog black or analog test signal outputs. By default, the CH 1, CH 2, and CH 3 connectors output black burst signals, and the CH 4 connector outputs an analog test signal. Use the System menu to change the output channel configuration.

CH 5, CH 6, CH 7, and CH 8 Analog black or analog test signal outputs (SPG600 Option 02 only). By default, the CH 5, CH 6, and CH 7 connectors output black burst signals, and the CH 8 connector outputs an analog test signal. Use the System menu to change the output channel configuration.

SDI 1 and SDI 2 Serial digital black or serial digital test signal outputs. By default, the SDI 1 connector outputs a serial digital black signal, and the SDI 2 connector outputs a serial digital test signal. Use the System menu to change the output channel configuration.

SDI 3 and SDI 4	Serial digital black or serial digital test signal outputs (SPG600 Option 03 only). By default, the SDI 3 connector outputs a serial digital black signal, and the SDI 4 connector outputs a serial digital test signal. Use the System menu to change the output channel configuration.
AES 1+2, AES 3+4, AES 5+6, and AES 7+8	AES/EBU serial digital audio outputs for channels 1 & 2, 3 & 4, 5 & 6, and 7 & 8 respectively (SPG600 only).
1+2/RIGHT and 3+4/LEFT (XLR connector)	AES/EBU serial digital audio or analog audio outputs for channels 1 & 2 and 3 & 4 respectively. By default, these connectors output an AES/EBS serial digital audio. Use the System menu to change the output configuration.
WORD CLK	48 kHz word clock signal output.



Reference

Menus

This section describes how to control all of the instrument functions using the front-panel buttons and menus.

Table 3-1 shows the instrument menus and page numbers for each menu description.

Table 3-1: Instrument menus and information pages

Button name	Menu	Page number
VIDEO	Video menu	page 3-2
AUDIO	Audio menu	page 3-17
GENLOCK	Genlock menu	page 3-23
SYSTEM	System menu	page 3-26

When you power on the sync pulse generator, the top menu item of the Video menu appears on the LCD display. Press any of the menu buttons to access a specific menu, and use the arrow buttons to scroll through menu items or available options. You need to press the ENTER button to enable the selected option or to access the associated submenu. Press the CANCEL button to disable the selected menu item and return to the previous menu item.

Almost all menus have two lines of text, where the first line shows the current menu item, and the second line shows the current selection (if there is not a submenu).

In the second line, a small square (■) shows that this item is currently selected and enabled in the available options. An Enter key mark (↵) shows that you need to press the ENTER button after selecting one of the options to implement the selection. See Figure 3-1. If the second line is empty, press the ENTER button to access the corresponding submenu.

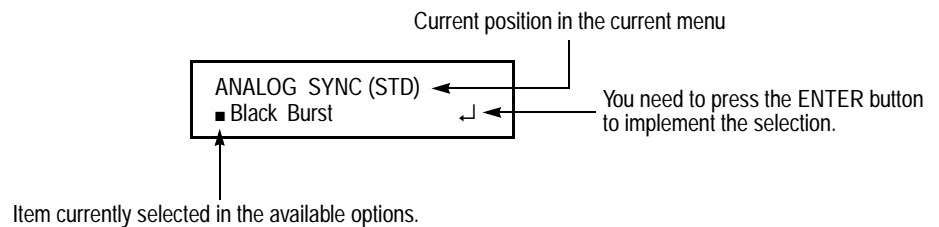
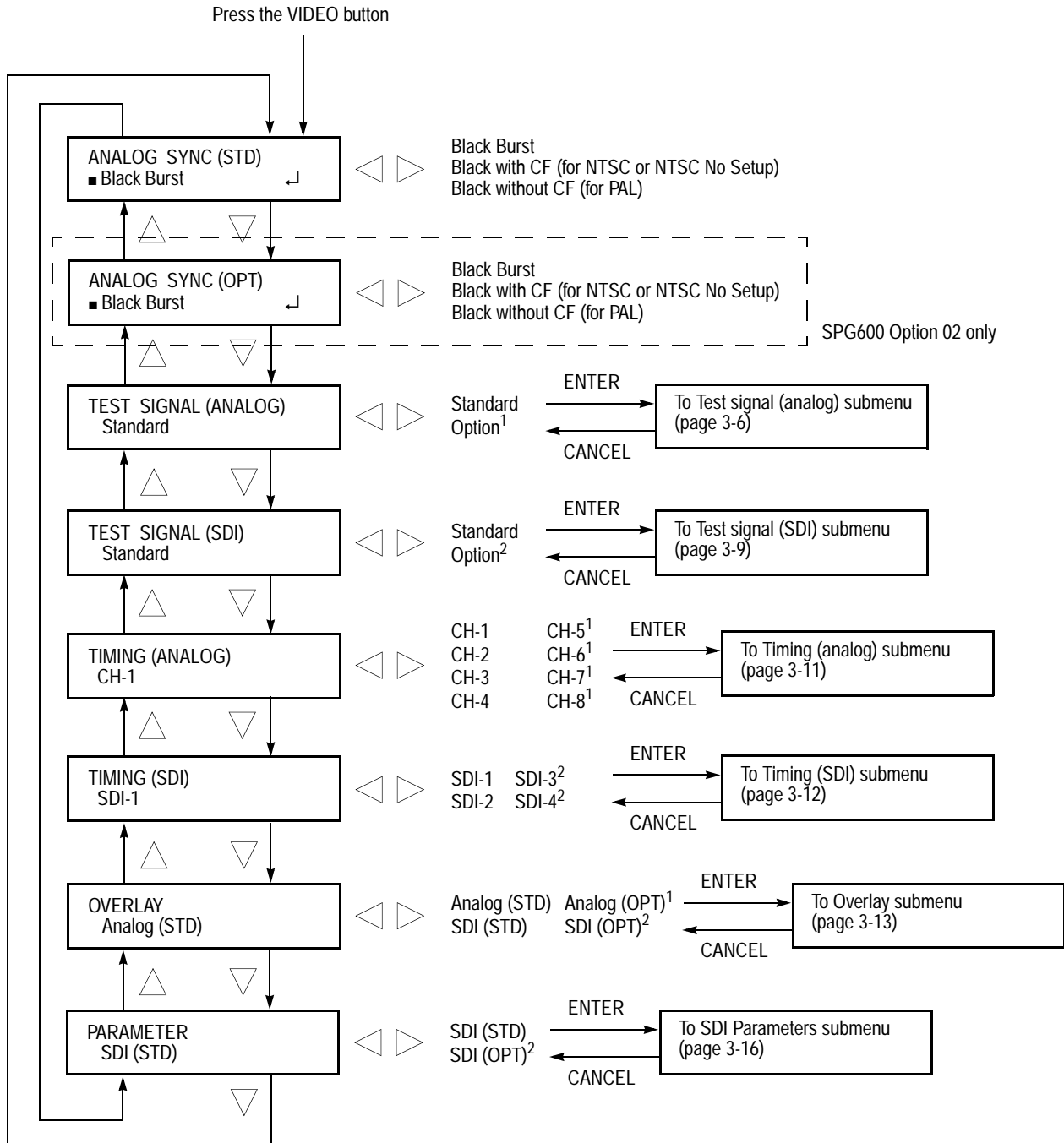

Figure 3-1: Example menu display

Video Menu

Pressing the VIDEO button displays the Video menu. This menu lets you set output signals, timing of the output signals, overlay, and SDI parameters. Use the up (▲) or down (▼) arrow button to scroll through the menu. Figure 3-2 shows the Video menu diagram.



1 SPG600 Option 02 only
 2 SPG600 Option 03 only

Figure 3-2: Video menu diagram

ANALOG SYNC (STD) Selects a black burst signal for the analog outputs. Use the left (◀) or right (▶) arrow button to select the signal. You can select **Black Burst**, **Black with CF** (for NTSC or NTSC No Setup), or **Black without CF** (for PAL).

Press the **ENTER** button to confirm the selection.

ANALOG SYNC (OPT) Selects a black burst signal for the optional analog outputs. Use the left (◀) or right (▶) arrow button to select the signal. You can select **Black Burst**, **Black with CF** (for NTSC or NTSC No Setup), or **Black without CF** (for PAL). This menu item is only available for the SPG600 Option 02.

Press the **ENTER** button to confirm the selection.

TEST SIGNAL (ANALOG) Selects a test signal for the analog outputs. Use the left (◀) or right (▶) arrow button to select **Standard** or **Option** (the SPG600 Option 02 only). When you select either of these items and then press the ENTER button, you will access the Test signal (analog) submenu. Refer to *Test Signal (Analog) Submenu* on page 3-6 for detailed information.

TEST SIGNAL (SDI) Selects a serial digital test signal for SDI outputs. Use the left (◀) or right (▶) arrow button to select **Standard** or **Option** (the SPG600 Option 03 only). When you select either of these items and then press the ENTER button, you will access the Test signal (SDI) submenu. Refer to *Test Signal (SDI) Submenu* on page 3-9 for detailed information.

TIMING (ANALOG) Adjusts the timing offset for the analog output signals to the internal reference signal (frame reset signal). Use the left (◀) or right (▶) arrow button to select **CH-1**, **CH-2**, **CH-3**, **CH-4**, **CH-5**, **CH-6**, **CH-7**, or **CH-8** (CH-5 to CH-8 are only available for the SPG600 Option02). When you select any of these items and then press the ENTER button, you will access the Timing (analog) submenu. Refer to *Timing (Analog) Submenu* on page 3-11 for detailed information.

TIMING (SDI) Adjusts the timing offset for the serial digital output signals to the internal reference signal (frame reset signal). Use the left (◀) or right (▶) arrow button to select **SDI-1**, **SDI- 2**, **SDI-3**, or **SDI-4** (SDI-3 and SDI-4 are only available for the SPG600 Option 03). When you select any of these items and then press the ENTER button, you will access the Timing (SDI) submenu. Refer to *Timing (SDI) Submenu* on page 3-12 for detailed information.

OVERLAY Selects an item (logo or ID text) that is overlaid on the test signal and sets its displayed position. Use the left (◀) or right (▶) arrow button to select **Analog (STD)**, **SDI (STD)**, **Analog (OPT)** (the SPG600 Option 02 only) or **SDI (OPT)** (the SPG600 Option 03 only). When you select either of these items and then press the ENTER button, you will access the Overlay submenu. Refer to *Overlay Submenu* on page 3-13 for detailed information.

PARAMETER Sets the resolution of the serial digital video signals, the insertion of the EDH (Error Detection and Handling), and which component(s) of the serial digital signal is(are) available. Use the left (◀) or right (▶) arrow button to select **SDI (STD)** or **SDI (OPT)** (SPG600 Option 03 Only). When you select either of these items and then press the ENTER button, you will access the SDI Parameters submenu. Refer to *SDI Parameters Submenu* on page 3-16 for detailed information.

**Test Signal (Analog)
Submenu**

This menu allows you to select a test signal for an analog output(s). Use the up (▲) or down (▼) arrow button to scroll through the menu. Figure 3-3 shows the Test signal (analog) submenu diagram.

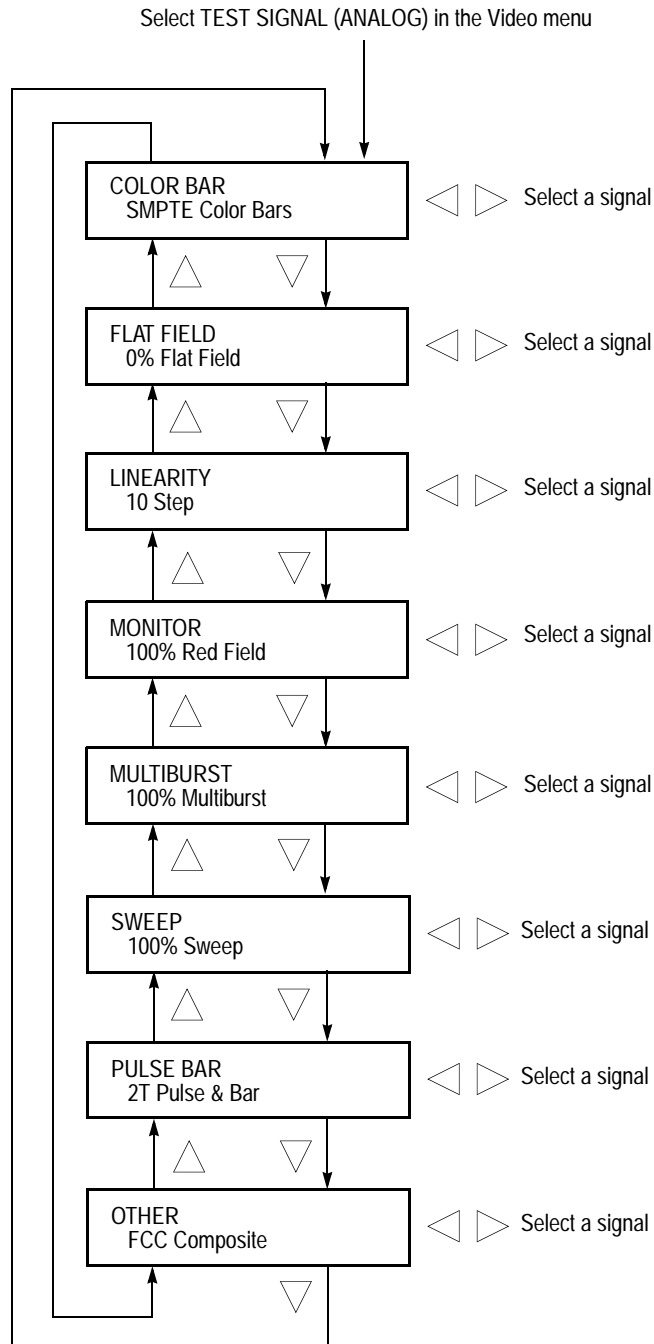

Figure 3-3: Test signal (analog) submenu diagram

NOTE. By default, the sync pulse generator is configured to output a test signal from the CH4 connector. You can change the configuration of the analog outputs using the Configuration submenu. Refer to the Configuration submenu on page 3-37.

After you select a signal set name (for example, COLOR BAR), use the left (◀) or right (▶) arrow button to select a signal. You do not need to press the ENTER button to enable the selection. Table 3-2 lists the available signals in each signal set.

Table 3-2: Selectable signals in each signal set (analog)

Signal set name	Selectable signals
NTSC format	
COLOR BAR	100% Color Bars, 75% Color Bars, SMPTE Color Bars
FLAT FIELD	0% Flat Field, 10% Flat Field, 40% Flat Field, 50% Flat Field, 100% Flat Field, Black Burst, Field Square Wave
LINEARITY	5 Step, 10 Step, Modulated 5 Step, Modulated Ramp, Modulated Pedestal, Ramp, Shallow Ramp
MONITOR	Convergence, 75% Red Field, 100% Red Field, White Window, Gray Window, 2 Pedestal & Pluge, 4 Pedestal & Pluge*, Safe Area*, Monitor Setup*
MULTIBURST	100% Multiburst, 60% Multiburst
SWEEP	100% Sweep, 60% Sweep, Chroma Freq. Resp.
PULSE BAR	2T Pulse & Bar, SinX/X, Multipulse
OTHER	SNG Color Bars, FCC Composite, FCC Multiburst, NTC7 Composite, NTC7 Combination, Matrix 1*
NTSC No Setup format	
COLOR BAR NO SETUP	100% Color Bars, 75% Color Bars, SMPTE Color Bars
FLAT FIELD	0% Flat Field, 10% Flat Field, 40% Flat Field, 50% Flat Field, 100% Flat Field, Black Burst, Field Square Wave
LINEARITY	5 Step, 10 Step, Modulated 5 Step, Modulated Ramp, Modulated Pedestal, Ramp, Shallow Ramp
MONITOR	Convergence, 75% Red Field, 100% Red Field, White Window, Gray Window, 2 Pedestal & Pluge, 4 Pedestal & Pluge*, Safe Area*, Monitor Setup*
MULTIBURST	100% Multiburst, 60% Multiburst
SWEEP	100% Sweep, 60% Sweep, Chroma Freq. Resp.
PULSE BAR	2T Pulse & Bar, SinX/X, Multipulse
OTHER	SNG Color Bars, FCC Composite, FCC Multiburst, NTC7 Composite, NTC7 Combination, Matrix 1*

Table 3-2: Selectable signals in each signal set (analog) (cont.)

Signal set name	Selectable signals
PAL format	
COLOR BAR	100% Colour Bars, 75% Colour Bars, 100% Bars Over Red, 75% Bars Over Red
FLAT FIELD	0% Flat Field, 40% Flat Field, 50% Flat Field, 100% Flat Field, Black Burst, Field Square Wave
LINEARITY	5 Step, 10 Step, Modulated 5 Step, Modulated 10 Step, Ramp, Modulated Ramp, Modulated Pedestal, Shallow Ramp
MONITOR	Convergence, 75% Red Field, 100% Red Field, White Window, Grey Window, 2 Pedestal & Pluge, 4 Pedestal & Pluge*, Safe Area*, Monitor Setup*
MULTIBURST	100% Multiburst, 60% Multiburst
SWEEP	100% Sweep, 60% Sweep
PULSE BAR	2T Pulse & Bar, Sin X/X
OTHER	CCIR 17, CCIR 18, CCIR 330, CCIR 331, UK ITS1, UK ITS 2, UK 1 Line ITS, ITS Matrix 1*

* These signals are only available in SPG600 Option 02.

NOTE. *The contents of each signal set are subject to change without notice due to continuous improvements of the instrument.*

Test Signal (SDI) Submenu This menu allows you to select a serial digital test signal for a SDI output(s). Use the up (▲) or down (▼) arrow button to scroll through the menu. Figure 3-4 shows the Test signal (SDI) submenu diagram.

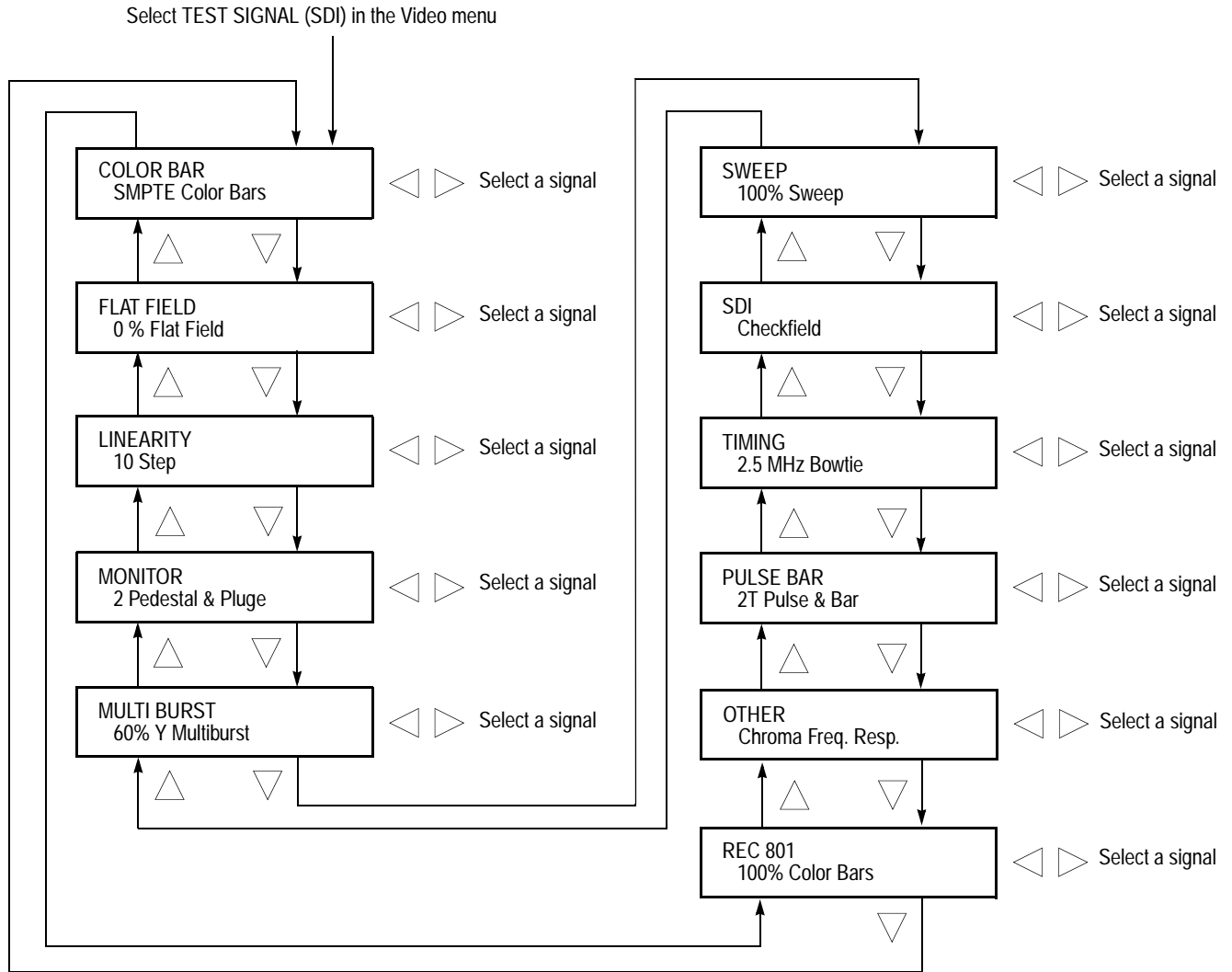

Figure 3-4: Test signal (SDI) submenu diagram

NOTE. By default, the sync pulse generator is configured to output a test signal from the SDI 2 connector. You can change the configuration of the SDI outputs using the Configuration submenu. Refer to the Configuration submenu on page 3-37.

After you select a signal set name (for example, COLOR BAR), use the left (◀) or right (▶) arrow button to select a signal. You do not need to press the ENTER button to enable the selection. Table 3-3 lists the available signals in each signal set.

Table 3-3: Selectable signals in each signal set (SDI)

Signal set name	Selectable signals
525-270 format	
COLOR BAR	100% Color Bars, 75% Color Bars, SMPTE Color Bars
FLAT FIELD	0% Flat Field, 20% Flat Field, 40% Flat Field, 50% Flat Field, 100% Flat Field, Field Square Wave
LINEARITY	5 Step, 10 Step, Modulated Ramp, Shallow Ramp, Valid Ramp, Y Valid Ramp, B-Y Valid Ramp, R-Y Valid Ramp, Limit Ramp, 3 Channel Ramp
MONITOR	Convergence, 75% Red Field, 75% Green Field, 75% Blue Field, White Window, Gray Window, Gamut Test, 2 Pedestal & Pluge, 4 Pedestal & Pluge*
MULTIBURST	60% Multiburst, 60% Y Multiburst
SWEEP	100% Sweep, 60% Sweep
SDI	Equalizer Test, PLL Test, Checkfield
TIMING	Active Pic. Timing, 500 kHz Bowtie, 2.5 MHz Bowtie, Co-siting Pulse
PULSE BAR	2T Pulse & Bar, T Pulses, SinX/X, Multipulse
OTHER	Chroma Freq. Resp., FCC Composite, FCC Multiburst, NTC7 Composite, NTC7 Combination, Color Palette*
REC 801	100% Color Bars, 75% Color Bars, Black, Gray, White, End-of-Line Pulses, Black-White Ramp, Yellow-Gray Ramp, Gray-Blue Ramp, Cyan-Gray Ramp, Gray-Red Ramp, Cb-Y-Cr-Y Ramp, White End-of-Line, Blue End-of-Line, Red End-of-Line, Yellow End-of-Line, Cyan End-of-Line
625-270 format	
COLOR BAR	100% Colour Bars, 75% Colour Bars, 100% Bars Over Red, 75% Bars Over Red
FLAT FIELD	0% Flat Field, 40% Flat Field, 50% Flat Field, 100% Flat Field, Field Square Wave
LINEARITY	5 Step, 10 Step, Modulated Ramp, Shallow Ramp, Y Valid Ramp, B-Y Valid Ramp, R-Y Valid Ramp, Limit Ramp, 3 Channel Ramp
MONITOR	Convergence, 75% Red Field, 75% Green Field, 75% Blue Field, 100% Red Field, White Window, Grey Window, Gamut Test, 2 Pedestal & Pluge, 4 Pedestal & Pluge*
MULTIBURST	60% Multiburst, 60% Y Multiburst
SWEEP	100% Sweep, 60% Sweep
SDI	Equalizer Test, PLL Test, Checkfield
TIMING	Active Pic. Timing, 500 kHz Bowtie, 2.5 MHz Bowtie, Co-siting Pulse
PULSE BAR	2T 10T Pulse & Bar, 2T 20T Pulse & Bar, SinX/X
OTHER	CCIR 17, CCIR18, CCIR 330, CCIR 331, CCIR 331 G2

Table 3-3: Selectable signals in each signal set (SDI) (cont.)

Signal set name	Selectable signals
REC 801	100% Colour Bars, 75% Colour Bars, Black, Grey, White, End-of-Line Pulses, Black-White Ramp, Yellow-Grey Ramp, Grey-Blue Ramp, Cyan-Grey Ramp, Grey-Red Ramp, Cb-Y-Cr-Y Ramp, White End-of-Line, Blue End-o- Line, Red End-of-Line, Yellow End-of-Line, Cyan End-of-Line

* These signals are only available in SPG600 Option 03.

NOTE. The contents of each signal set are subject to change without notice due to continuous improvements of the instrument.

Timing (Analog) Submenu

This menu allows you to adjust the timing offset of the selected analog output relative to the genlock signal or the internal reference signal. Use the up (▲) or down (▼) arrow button to scroll through the menu. Figure 3-5 shows the Timing (analog) submenu diagram.

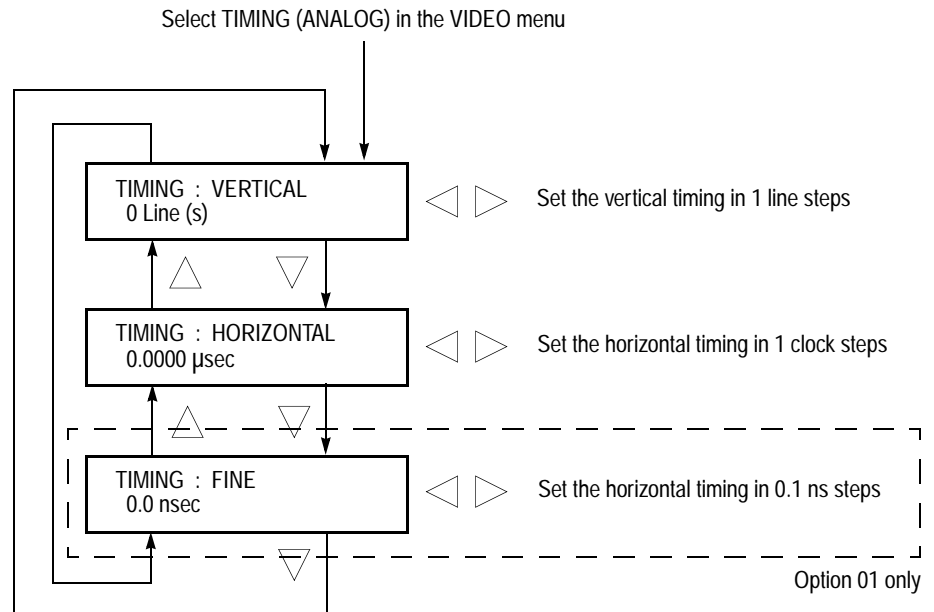

Figure 3-5: Timing (analog) submenu diagram

VERTICAL. Use the left (◀) or right (▶) arrow button to adjust the vertical offset. The value wraps around, so when the maximum value is reached the next value is the minimum value. The range of the timing adjustment depends on the selected video standard. Refer to Table 3-4 for the appropriate range.

HORIZONTAL. Use the left (◀) or right (▶) arrow button to adjust the horizontal offset. The value wraps around, so when the maximum value is reached the next value is the minimum value. The range of the timing adjustment depends on the selected video standard. Refer to Table 3-4 for the appropriate range.

FINE. This menu item is only available if Option 01 is installed. You can set the value from -18.5 ns to +18.5 ns in 0.1 ns steps. Use the left (◀) or right (▶) arrow button to adjust the fine horizontal offset.

Table 3-4: Analog output timing range

Format name	Vertical settings (line)	Horizontal settings (μs)
NTSC	-525 to +525	-63.5556 to + 63.5185
PAL	-1250 to +1250	-63.9630 to +63.9630

Timing (SDI) Submenu

This menu allows you to adjust the timing offset of the selected serial digital output relative to the genlock signal or the internal reference signal. Use the up (▲) or down (▼) arrow button to scroll through the menu. Figure 3-6 shows the Timing (SDI) submenu diagram.

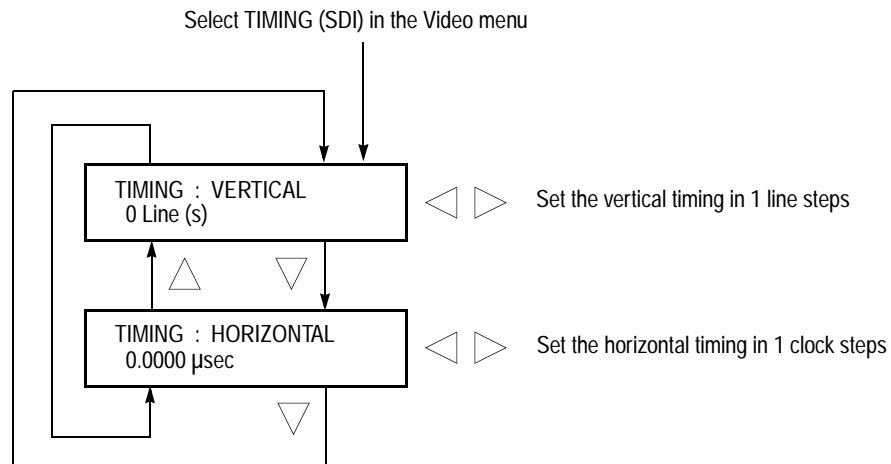

Figure 3-6: Timing (SDI) submenu diagram

VERTICAL. Use the left (◀) or right (▶) arrow button to adjust the vertical offset. The value wraps around, so when the maximum value is reached the next value is the minimum value. The range of the timing adjustment depends on the selected video standard. Refer to Table 3-5 for the appropriate range.

HORIZONTAL. Use the left (◀) or right (▶) arrow button to adjust the horizontal offset. The value wraps around, so when the maximum value is reached the next value is the minimum value. The range of the timing adjustment depends on the selected video standard. Refer to Table 3-5 for the appropriate range.

Table 3-5: SDI output timing range

Format name	Vertical settings (line)	Horizontal settings (µs)
525-270	-525 to +525	-63.5556 to +63.5185
625-270	-625 to +625	-63.9630 to +63.9630

Overlay Submenu

This menu allows you to select an item (logo or ID text) that is overlaid on the output test signal, and to set the blinking mode for the overlay. Use the up (▲) or down (▼) arrow button to scroll through the menu. Figure 3-7 shows the Overlay submenu diagram.

NOTE. The contents of the Overlay submenu are common for both analog and serial digital signals except for the menu title on the first line (ANALOG or SDI).

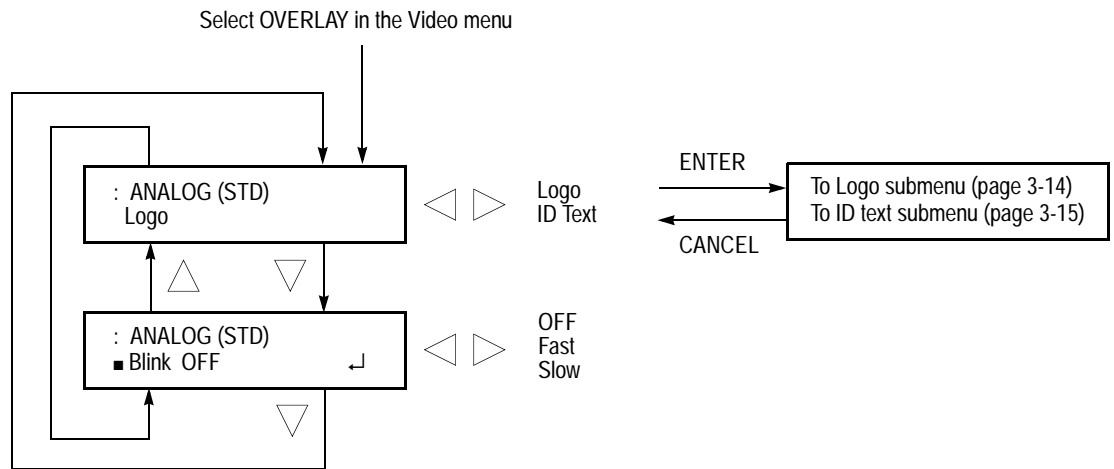

Figure 3-7: Overlay submenu diagram

Object. Selects an item that is overlaid on the output test signal. Use the left (◀) or right (▶) arrow button to select **Logo** or **ID Text**. When you select either of these items and then press the ENTER button, you will access the submenu for setting that overlay. Refer to *Logo Submenu* on page 3-14 or *ID Text Submenu* on page 3-15 for detailed information.

Blink. Sets the blinking mode for the overlay. Use the left (◀) or right (▶) arrow button to select **OFF**, **Fast** (blinks approximately at a 1.0 second interval) or **Slow** (blinks approximately at a 2.0 second interval). Press the ENTER button to confirm the selection.

Logo Submenu

This menu allows you to overlay and position a logo graphic on an output test signal. Use the up (▲) or down (▼) arrow button to scroll through the menu. Figure 3-8 shows the Logo submenu diagram.

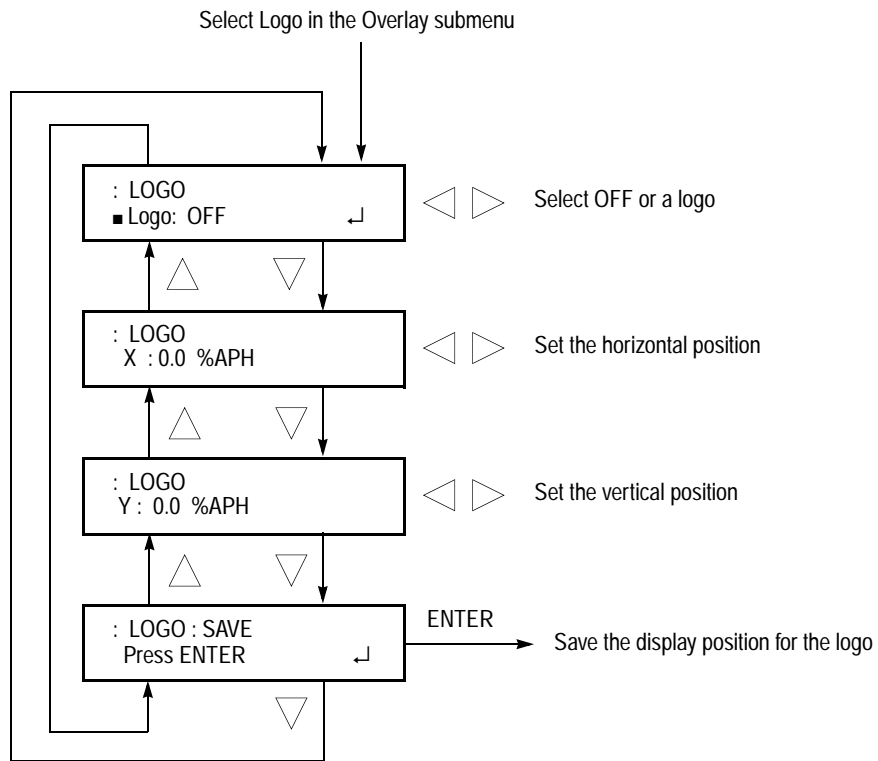

Figure 3-8: Logo submenu diagram

Logo. Selects the logo you want to display. Use the left (◀) or right (▶) arrow button to select **OFF** or a logo file name. Press the **ENTER** button to confirm the selection. When you select **OFF**, the logo overlay is disabled.

You can create a logo file using the Logo Generator application. Refer to *Appendix C: Using Logo Generator* for more information.

X. Sets the horizontal position of the logo. The position is set as a percentage of active picture width. Use the left (◀) or right (▶) arrow button to change the position. You can set the value from -100.0% to 0.0% in 1% steps.

Y. Sets the vertical position of the logo. The position is set as a percentage of active picture width. Use the left (◀) or right (▶) arrow button to change the position. You can set the value from -100.0% to 0.0% in 1% steps.

SAVE. Saves the display position for the logo to a logo file. Press the **ENTER** button to save the current settings.

ID Text Submenu

This menu allows you to edit and position a text string that is overlaid on the output test signal. Use the up (▲) or down (▼) arrow button to scroll through the menu. Figure 3-9 shows the ID text submenu diagram.

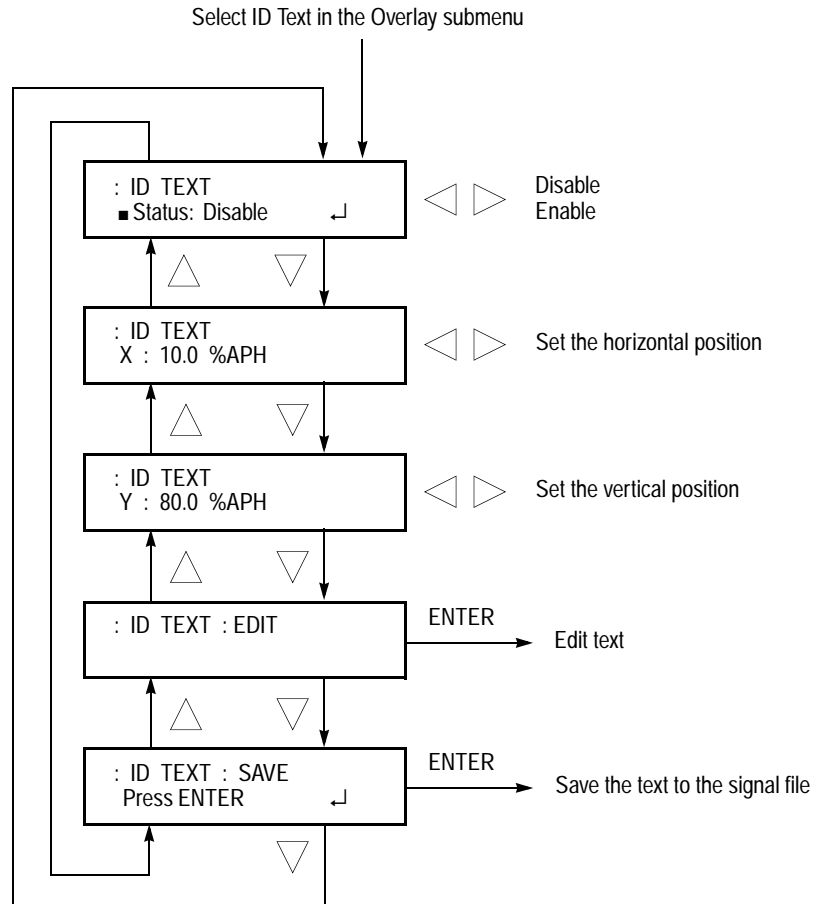

Figure 3-9: ID text submenu diagram

Status. Enables or disables the text overlay. Use the left (◀) or right (▶) arrow button to select between **Disable** and **Enable**. Press the **ENTER** button to confirm the selection.

X. Sets the horizontal position of the text. The position is set as a percentage of active picture width. Use the left (◀) or right (▶) arrow button to change the position. You can set the value from -100.0% to 0.0% in 1% steps.

Y. Sets the vertical position of the text. The position is set as a percentage of active picture width. Use the left (◀) or right (▶) arrow button to change the position. You can set the value from -100.0% to 0.0% in 1% steps.

EDIT. Edits the text you want to display on the output test signal.

To edit the text, first press the **ENTER** button to enable the text edit mode. Use the left (◀) or right (▶) arrow button to move the underscore character (_) to the character you want to change, and then use the up (▲) or down (▼) arrow button to change the selected character. When you enter all of the desired characters then press the **ENTER** button to end the text editing process. You can use up to 20 characters for the text. Use the blank character to erase a character.

SAVE. Saves the text and its position to the signal file currently being output. Press the **ENTER** button to save the text and its position to the signal file.

SDI Parameters Submenu

This menu allows you to select which component(s) of the serial digital signal is (are) available, the serial digital signal resolution, and the insertion of the EDH (Error Detection and Handling) bits. Use the up (▲) or down (▼) arrow button to scroll through the menu. Figure 3-10 shows the SDI parameters submenu diagram.

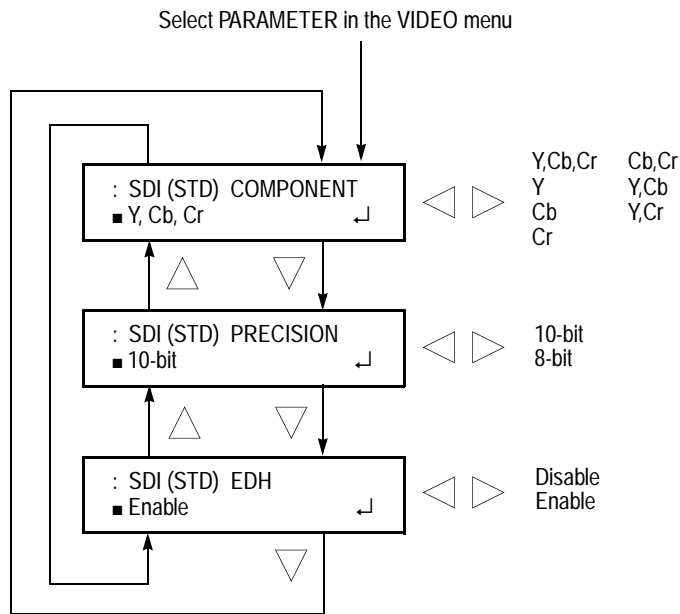

Figure 3-10: SDI parameters submenu diagram

COMPONENT. Selects which component(s) of the serial digital signal is(are) available. Use the left (◀) or right (▶) arrow button to make selection. You can select **Y,Cb,Cr**, **Y**, **Cb**, **Cr**, **Cb,Cr**, **Y,Cb**, or **Y,Cr**. Press the **ENTER** button to confirm the selection.

PRECISION. Sets the resolution of the serial digital video signals. Use the left (◀) or right (▶) arrow button to select between **10-bit** and **8-bit**. Press the **ENTER** button to confirm the selection.

EDH. Enables or disables the insertion of the EDH (Error Detection and Handling) information on the serial digital video signals. Use the left (◀) or right (▶) arrow button to select between **Disable** and **Enable**. Press the **ENTER** button to confirm the selection.

Audio Menu

Pressing the AUDIO button displays the Audio menu. This menu lets you set the parameters of the AES/EBU audio and embedded audio in the serial digital signal. Use the up (▲) or down (▼) arrow button to scroll through the menu. Figure 3-11 shows the Audio menu diagram.

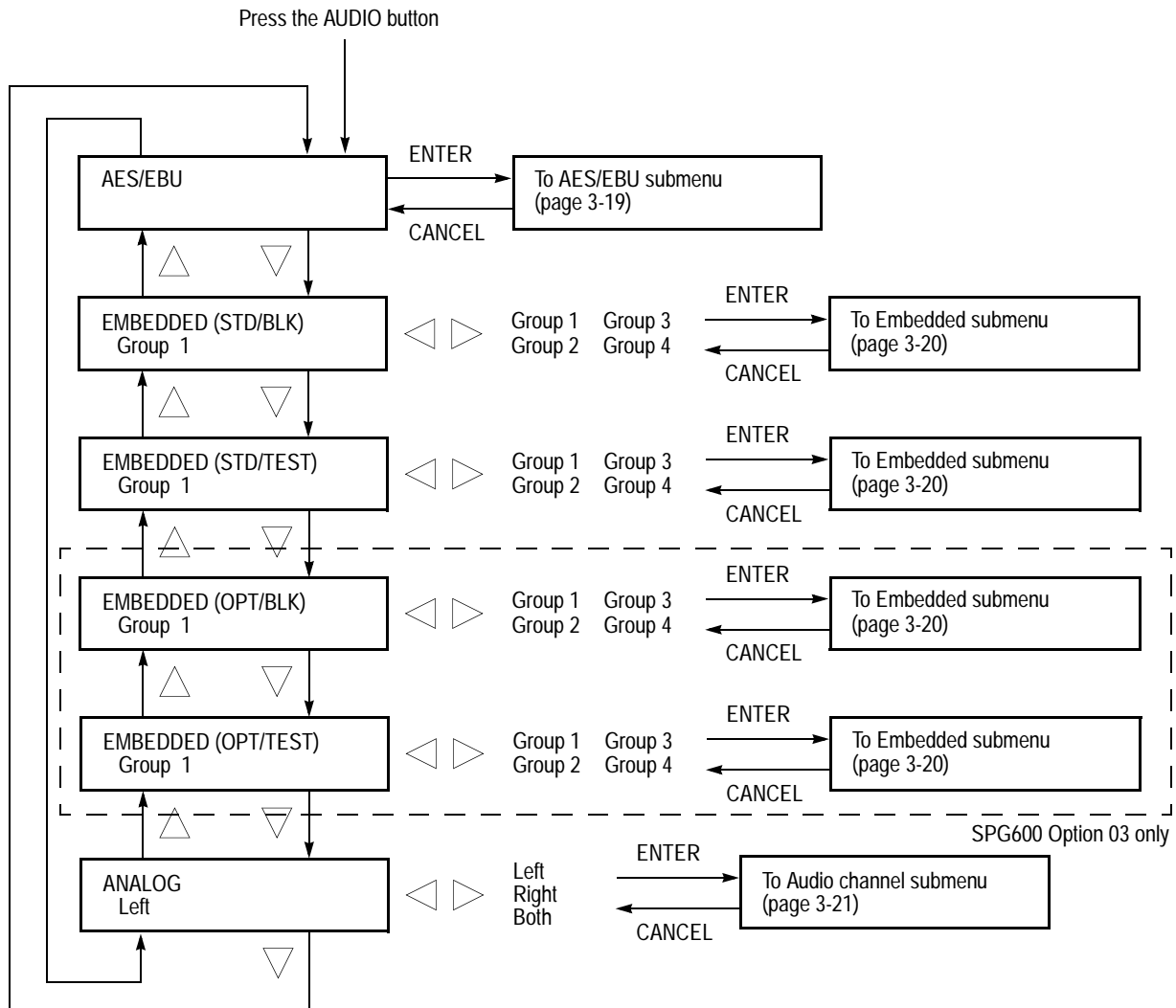

Figure 3-11: Audio menu diagram

AES/EBU Sets the parameters for AES/EBU serial audio. When you select this menu item and then press the ENTER button, you will access the AES/EBU submenu. Refer to *AES/EBU Submenu* on page 3-19 for detailed information.

EMBEDDED (STD/BLK) Sets the parameters for embedded audio on the serial digital black signals. Use the left (◀) or right (▶) arrow button to select **Group 1**, **Group 2**, **Group 3**, or **Group 4**. When you select either of the groups and then press the ENTER button, you will access the Embedded submenu. Refer to *Embedded Submenu* on page 3-20 for detailed information.

EMBEDDED (STD/TEST) Sets the parameters for embedded audio on the serial digital test signals. Use the left (◀) or right (▶) arrow button to select **Group 1**, **Group 2**, **Group 3**, or **Group 4**. When you select either of the groups and then press the ENTER button, you will access the Embedded submenu. Refer to *Embedded Submenu* on page 3-20 for detailed information.

EMBEDDED (OPT/BLK) Sets the parameters for embedded audio on the serial digital black signals. Use the left (◀) or right (▶) arrow button to select **Group 1**, **Group 2**, **Group 3**, or **Group 4**. When you select either of the groups and then press the ENTER button, you will access the Embedded submenu. Refer to *Embedded Submenu* on page 3-20 for detailed information. This menu item is only available for the SPG600 Option 03.

EMBEDDED (OPT/TEST) Sets the parameters for embedded audio on the serial digital test signals. Use the left (◀) or right (▶) arrow button to select **Group 1**, **Group 2**, **Group 3**, or **Group 4**. When you select either of the groups and then press the ENTER button, you will access the Embedded submenu. Refer to *Embedded Submenu* on page 3-20 for detailed information. This menu item is only available for the SPG600 Option 03.

ANALOG Selects an audio channel(s) when outputting an analog audio signal from the XLR connectors. Use the left (◀) or right (▶) arrow button to select **Left**, **Right**, or **Both**. When you select either of the channels and then press the ENTER button, you will access the Audio Channel submenu. Refer to *Audio Channel Submenu* on page 3-21 for detailed information. This menu item is only available when you select Analog Audio in the CONFIGURATION: XLR OUTPUT menu.

AES/EBU Submenu

This menu allows you to select an audio channel, the state of the audio emphasis bits, and the resolution of the serial digital audio signal data, and to set the audio timing. Use the up (▲) or down (▼) arrow button to scroll through the menu.

Figure 3-12 shows the AES/EBU submenu diagram.

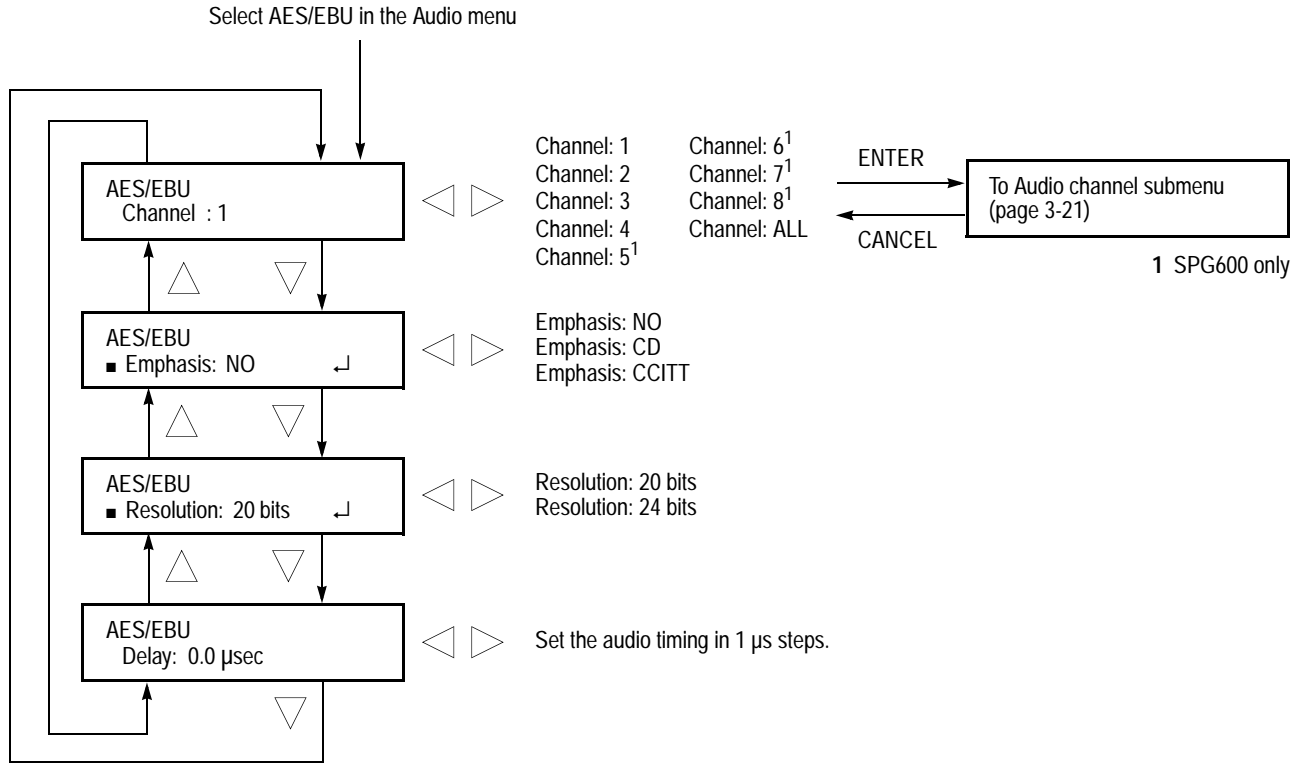

Figure 3-12: AES/EBU submenu diagram

Channel. Selects the channel where you will change the parameters. Use the left (◀) or right (▶) arrow button to select **1, 2, 3, 4, 5, 6, 7, 8,** or **ALL** (5 to 8 are only available for the SPG600). When you select any of the channels and then press the ENTER button, you will access the Audio channel submenu. Refer to *Audio Channel Submenu* on page 3-21 for detailed information.

Emphasis. Selects the state of emphasis bits of AES/EBU serial audio. Use the left (◀) or right (▶) arrow button to select **NO** (no emphasis bits), **CD**, or **CCITT**. Press the **ENTER** button to confirm the selection.

Resolution. Selects the resolution of AES/EBU serial audio sample data. Use the left (◀) or right (▶) arrow button to select between **20 bits** and **24 bits**. Press the **ENTER** button to confirm the selection.

Delay. Adjust the timing offset of the audio signal outputs relative to the internal reference signal (frame reset signal). Use the left (◀) or right (▶) arrow button to change the value. You can set the value from -160 ms to +160 ms (PAL) in 1 μs steps. A plus timing value is set as **Delay** and minus timing value is set as **Advance**.

Embedded Submenu

This menu allows you to enable or disable the generation of embedded audio, select an audio channel, set the state of the audio emphasis bits, and set the resolution of the serial digital audio signal data. Use the up (▲) or down (▼) arrow button to scroll through the menu. Figure 3-13 shows the Embedded submenu diagram.

NOTE. The contents of the Embedded submenu are common for the serial digital black signals and the serial digital test signals except for the menu title on the first line.

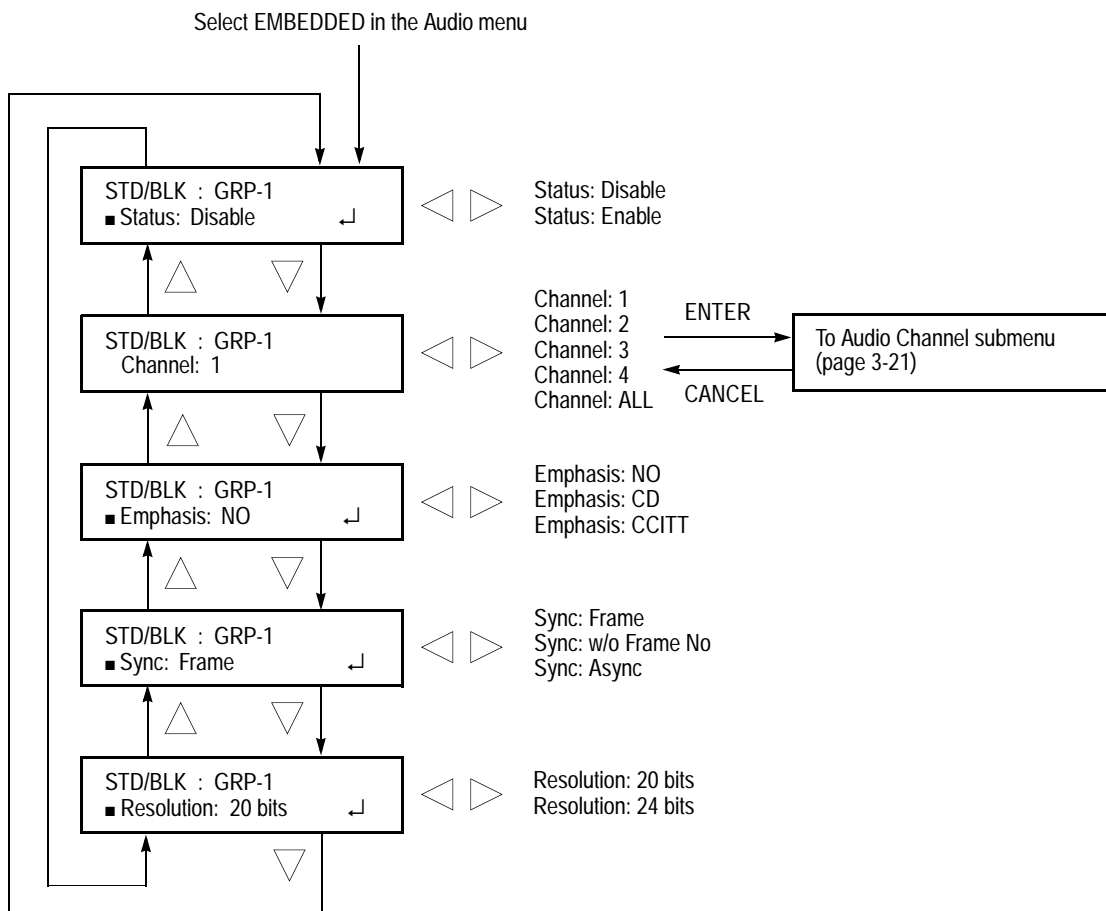

Figure 3-13: Embedded submenu diagram

Status. Enables or disables the generation of embedded audio. Use the left (◀) or right (▶) arrow button to select between **Enable** and **Disable**. Press the **ENTER** button to confirm the selection.

Channel. Selects the channel where you will change the parameters. Use the left (◀) or right (▶) arrow button to select **1, 2, 3, 4, or All**. When you select any of the channels and then press the **ENTER** button, you access the Audio channel submenu. Refer to *Audio Channel Submenu* on page 3-21 for detailed information.

Emphasis. Selects the state of emphasis bits of embedded audio. Use the left (◀) or right (▶) arrow button to select **NO** (no emphasis bits), **CD**, or **CCITT**. Press the **ENTER** button to confirm the selection.

Sync. Selects the sampling alignment status bits of embedded audio. Use the left (◀) or right (▶) arrow button to select **Frame, w/o Frame No.** (without frame number), or **Async** (asynchronous). Press the **ENTER** button to confirm the selection.

Resolution. Selects the resolution of embedded audio sample data. Use the left (◀) or right (▶) arrow button to select between **20 bits** and **24 bits**. Press the **ENTER** button to confirm the selection.

Audio Channel Submenu

This menu allows you to set the frequency, amplitude, and audio click of the selected audio channel. Use the up (▲) or down (▼) arrow button to scroll through the menu. Figure 3-14 shows the Audio channel submenu diagram.

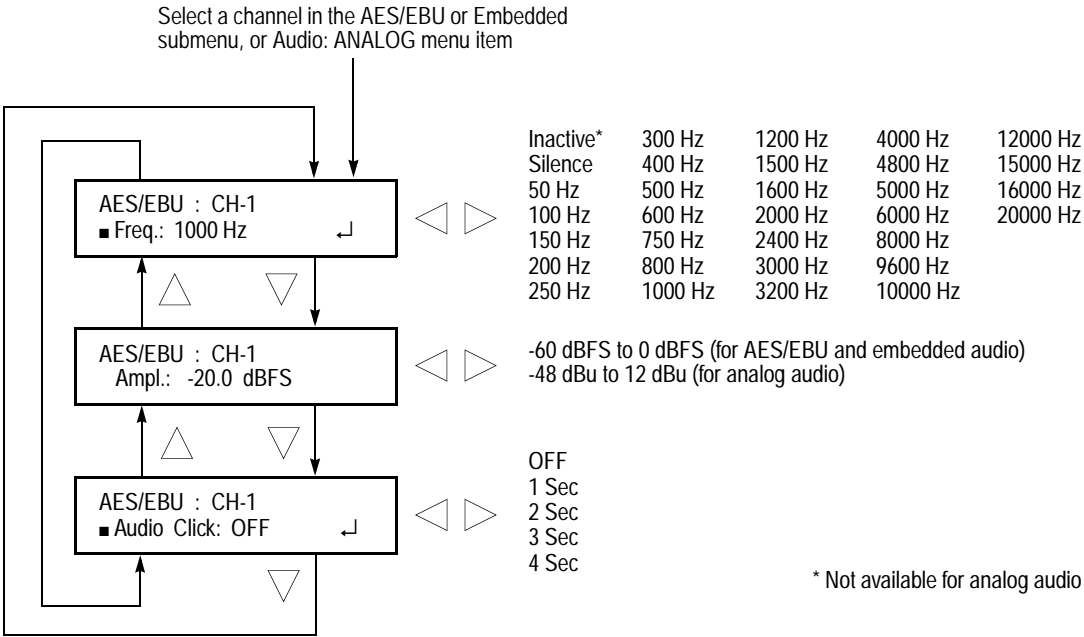

Figure 3-14: Audio channel submenu diagram

NOTE. The Audio channel submenu contents are common for AES/EBU audio, embedded audio, and analog audio except for the menu title on the first line and some parameter settings.

Frequency. Sets the audio signal frequency for the selected audio channel. Use the left (◀) or right (▶) arrow button to make the selection. The choices are:

Inactive	400 Hz	1600 Hz	6000 Hz
Silence	500 Hz	2000 Hz	8000 Hz
50 Hz	600 Hz	2400 Hz	9600 Hz
100 Hz	750 Hz	3000 Hz	10000 Hz
150 Hz	800 Hz	3200 Hz	12000 Hz
200 Hz	1000 Hz	4000 Hz	15000 Hz
250 Hz	1200 Hz	4800 Hz	16000 Hz
300 Hz	1500 Hz	5000 Hz	20000 Hz

When Inactive is selected, audio data output is disabled (Inactive is not available for analog audio). Press the **ENTER** button to confirm the selection.

Amplitude. Sets the audio signal amplitude for the selected audio channel. Use the left (◀) or right (▶) arrow button to set the value. You can set the value from -60 dBFS to 0 dBFS in 1 dBFS steps for AES/EBU and embedded audio, and from -48 dBu to 12 dBu in 1 dBu steps for analog audio.

Audio Click. Inserts audio clicks in the selected audio channel. The audio tone, if any, is turned off for an interval around the audio click. Use the left (◀) or right (▶) arrow button to make the selection. The choices are **OFF**, **1 Sec**, **2 Sec**, **3 Sec**, and **4 Sec**. Press the **ENTER** button to confirm the selection.

Audio click becomes valid when you select **1 Sec** to **4 Sec** for the audio click rate. When the audio click is valid, audio tone is turned off for 0.25 seconds around the click. For example, if you select **3 Sec** for the click rate, the audio tone will be output for 2.75 seconds, and silent for 0.25 seconds; the click occurs during this silence. When Audio Click is set to **OFF**, the audio tone selected in the Frequency menu is output continuously. Audio Click makes it easy to identify any channel(s) of the four output channels.

Genlock Menu

Pressing the GENLOCK button displays the Genlock menu. This menu lets you select the genlock source, set the timing offset, and set the instrument actions when lock is lost. Use the up (▲) or down (▼) arrow button to scroll through the menu. Figure 3-15 shows the Genlock menu diagram.

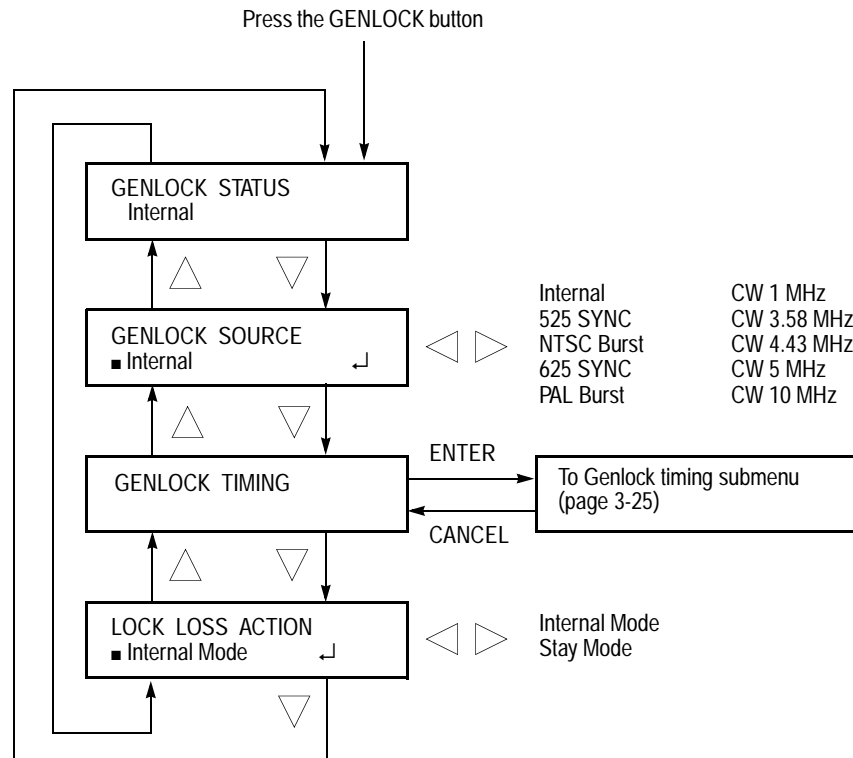

Figure 3-15: Genlock menu diagram

GENLOCK STATUS Displays the genlock source and status. The possible messages for the status are: **Internal**, **Locked**, **Loss of Lock**, and **No Signal**.

GENLOCK SOURCE Selects the signal source to genlock. Use the left (◀) or right (▶) arrow button to select the genlock source. The choices are:

Internal. Uses the internal reference signal.

525 SYNC. Sync locks to an NTSC black burst signal applied to the REF connector.

NTSC Burst. Burst locks to an NTSC black burst signal applied to the REF connector.

625 SYNC. Sync locks to a PAL black burst signal applied to the REF connector.

PAL Burst. Burst locks to a PAL black burst signal applied to the REF connector.

CW 1, 3.58, 4.43, 5, and 10 MHz. Locks to 1, 3.58, 4.43, 5, and 10 MHz continuous wave signals applied to the REF connector respectively.

Press the **ENTER** button to confirm the selection.

GENLOCK TIMING

Adjusts the timing offset of the input signal relative to the internal reference signal (frame reset signal). When you select this menu item and then press the ENTER button, you will access the Genlock timing submenu. Refer to *Genlock Timing Submenu* on page 3-25 for detailed information.

LOCK LOSS ACTION

Sets the way the sync pulse generator will react when a loss of genlock state occurs (for example, genlock source is absent or incompatible). The selections are:

Internal Mode. When a loss of genlock state occurs, the instrument automatically switches to the internal reference, and the EXT.REF indicator blinks.

Stay Mode. When a loss of genlock state occurs, the instrument maintains the current state.

Press the **ENTER** button to confirm the selection.

Genlock Timing Submenu

This menu allows you to adjust the timing offset of the input signal relative to the internal reference signal (frame reset signal). Use the up (▲) or down (▼) arrow button to scroll through the menu. Figure 3-16 shows the Genlock timing submenu diagram.

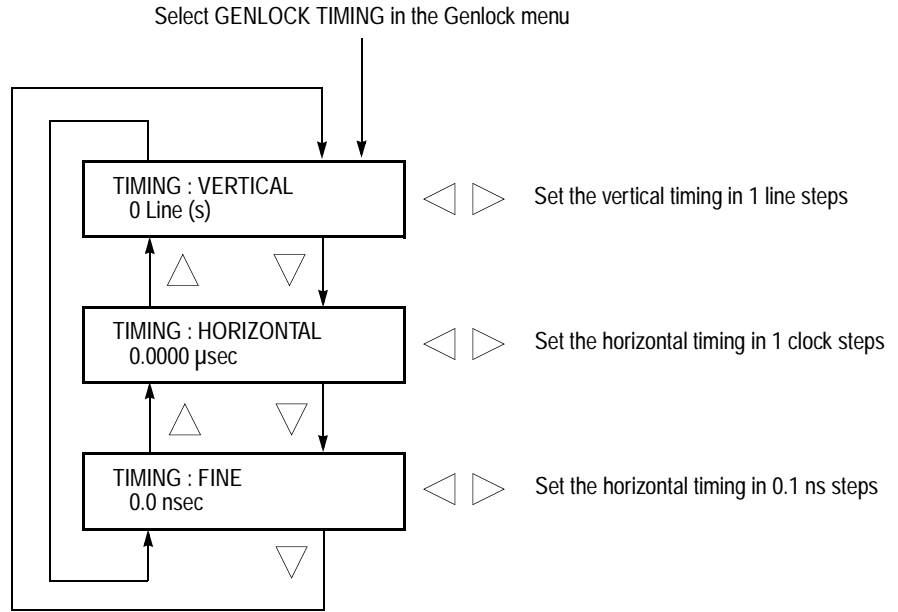

Figure 3-16: Genlock timing submenu diagram

VERTICAL. Use the left (◀) or right (▶) arrow button to adjust the vertical offset. The value wraps around, so when the maximum value is reached the next value is the minimum value. The range of the timing adjustment depends on the selected signal format. Refer to Table 3-6 for the appropriate range.

HORIZONTAL. Use the left (◀) or right (▶) arrow button to adjust the coarse horizontal offset. The value wraps around, so when the maximum value is reached the next value is the minimum value. The range of the timing adjustment depends on the selected signal format. Refer to Table 3-6 for the appropriate range.

FINE. Use the left (◀) or right (▶) arrow button to adjust the fine horizontal offset. You can set the value from -18.5 ns to +18.5 ns in 0.1 ns steps.

Table 3-6: Genlock timing range

Format name	Vertical settings	Horizontal settings (μs)
NTSC	-525 to +525	-63.5556 to +63.5185
PAL	-1250 to +1250	-64.0000 to +63.9630

System Menu

Pressing the **SYSTEM** button displays the System menu. This menu lets you set the system-related settings such as network parameters and output configuration. Use the up (▲) or down (▼) arrow button to scroll through the menu. Figure 3-17 shows the System menu diagram.

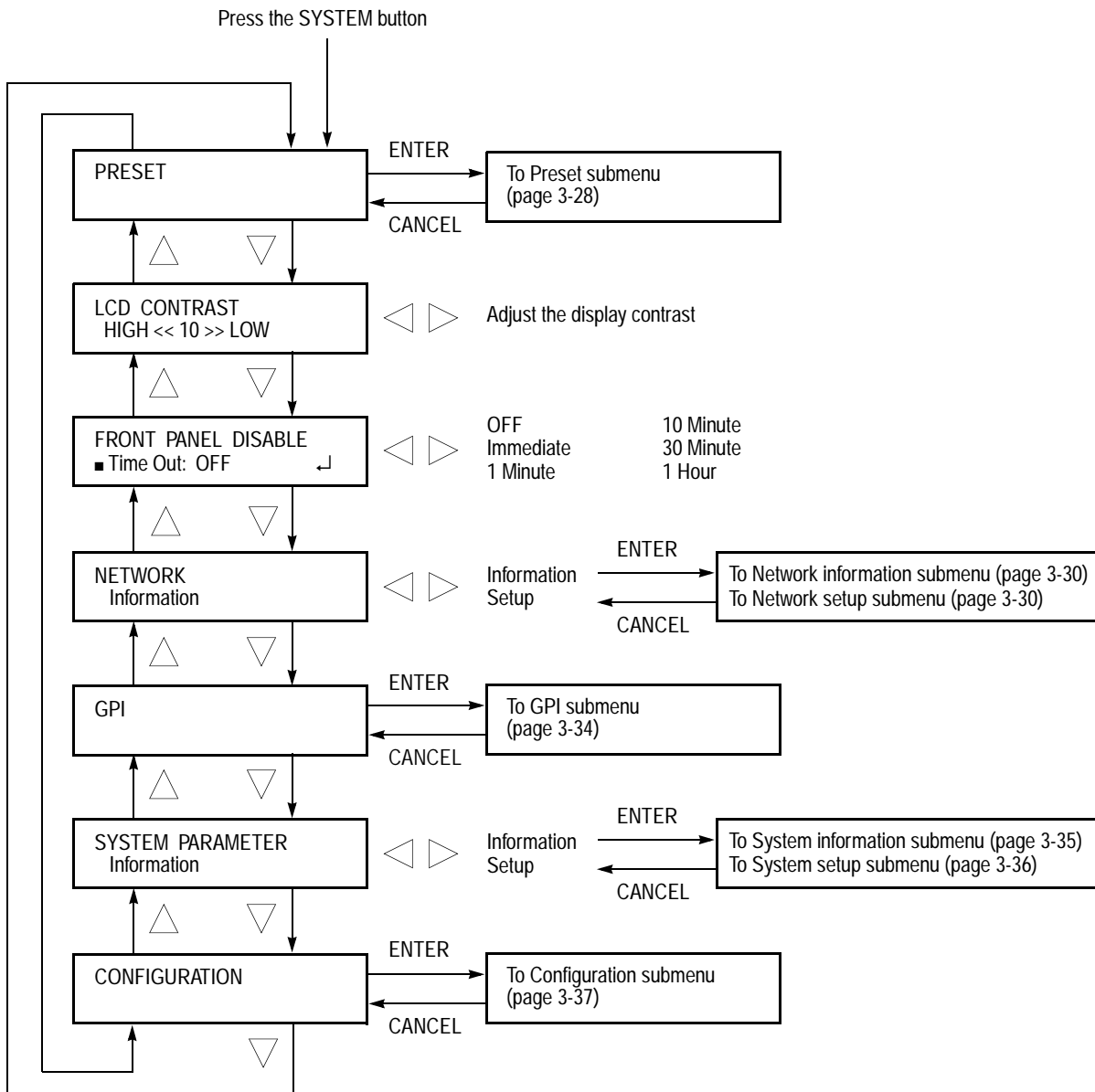

Figure 3-17: System menu diagram

-
- PRESET** Recalls instrument settings saved as a preset, or saves the current instrument settings as a preset. When you select this menu item and then press the ENTER button, you access the PRESET submenu. Refer to *Preset Submenu* on page 3-28 for detailed information.
- LCD CONTRAST** Adjusts the contrast of the LCD display. You can raise the contrast by pressing left (◀) arrow button and lower the contrast by pressing the right (▶) arrow button.
- FRONT PANEL DISABLE** Sets the timeout period until the front-panel buttons are disabled. Use the left (◀) or right (▶) arrow button to make the selection. The choices are **OFF**, **Immediate**, **1 Minute**, **10 Minute**, **30 Minute**, and **1 Hour**. Press the ENTER button to confirm the selection.
- NETWORK** Displays the current network parameters or sets the network parameters for the 100BASE-T port on the sync pulse generator. Use the left (◀) or right (▶) arrow button to toggle between **Information** and **Setup**. When you select Information and press the ENTER button, you will access the Network information submenu. When you select Setup and press the ENTER button, you will access the Network setup submenu.
- Refer to *Network Information Submenu* on page 3-30 for detailed information about the submenu. Also, refer to *Network Setup Submenu* on page 3-30 for detailed information about the submenu.
- GPI** Enables and resets the alarm signal output and displays the alarm status. When you select the menu item and then press the ENTER button, you will access the GPI submenu. Refer to *GPI Submenu* on page 3-34 for detailed information
- SYSTEM PARAMETER** Displays the system information of the sync pulse generator, and enters the option key (alphanumeric code) to enable the fine timing feature (Option 01). Use the left (◀) or right (▶) arrow button to toggle between **Information** and **Setup**. When you select Information and press the ENTER button, you will access the System information submenu. When you select Setup and press the ENTER button, you will access the System setup submenu.
- Refer to *System Information Submenu* on page 3-35 for detailed information about the submenu. Also, refer to *System Setup Submenu* on page 3-36 for detailed information about the submenu.
- CONFIGURATION** Sets the configuration of the output connectors. When you select the menu item and then press the ENTER button, you will access the Configuration submenu. Refer to *Configuration Submenu* on page 3-37 for detailed information.

Preset Submenu This menu allows you to store and recall instrument configuration settings. Use the up (▲) or down (▼) arrow button to scroll through the menu. Figure 3-18 shows the Preset submenu diagram.

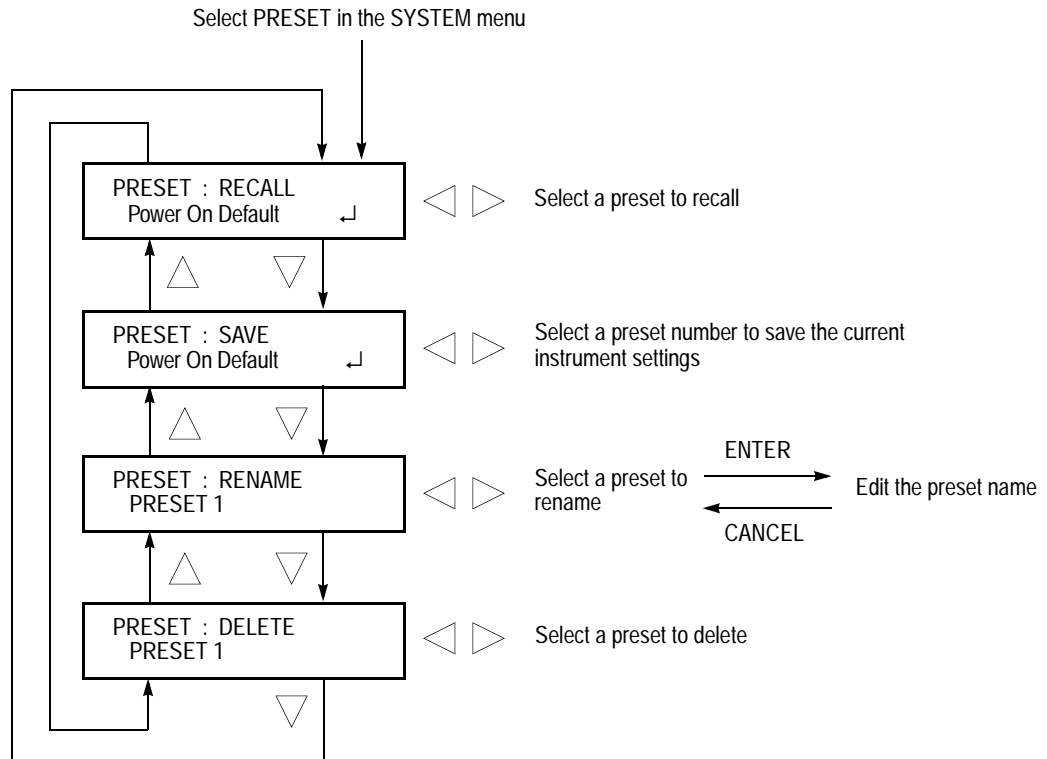

Figure 3-18: Preset submenu diagram

The following three presets are named at the factory and can be used for your own application:

- **Power On Default:** When you save instrument settings in the preset, the instrument settings can be loaded into the sync pulse generator automatically at power on.

NOTE. *If you want to save network parameters to a preset, use the Power On Default preset.*

- **User Default:** The preset for saving the user specified default settings. If you save new instrument settings in this preset, a confirmation message appears to prevent overwriting.
- **Factory Default:** In this preset, the factory default settings are saved. Use this preset to reset the sync pulse generator to the factory default settings. The following settings are not affected by the factory default: LCD contrast, front-panel timeout, and network address parameters.

For details on default settings, refer to *Factory Default Settings* on page 3-45.

RECALL. Recalls saved instrument presets. Use the left (◀) or right (▶) arrow button to select the desired preset, and then press the **ENTER** button to implement the selection.

SAVE. Saves the current instrument settings to one of the seven presets (User Default, Power On Default, and PRESET 1 to 5). Use the left (◀) or right (▶) arrow button to select the destination preset, and then press the **ENTER** button to implement the selection.

RENAME. Renames the specified preset name. Perform the following steps to change a preset name:

1. Use the left (◀) or right (▶) arrow button to select the preset you want to rename. The underscore character (_) appears under the first letter of the preset name.
2. Press the **ENTER** button twice to begin editing the preset name.
3. Use the left (◀) or right (▶) arrow button to move the underscore character to the letter you want to modify.
4. Use the up (▲) or down (▼) arrow button to select the new character.

The available characters include the full English alphabet, numerals from 0 to 9, and many standard ASCII symbols. The text strings can contain up to 18 characters.

5. Enter all of the desired characters, then press the **ENTER** button.
6. Press the **CANCEL** button twice to exit the Preset submenu. This returns to the top of the System menu.
7. Press the **ENTER** button to re-enter the Preset submenu.
8. Use the up (▲) or down (▼) arrow button to select the SAVE menu items.
9. Use the left (◀) or right (▶) arrow button to select the preset name edited in step 4.
10. Press the **ENTER** button to save the preset with the new name.

DELETE. Deletes the contents of the specified preset. Use the left (◀) or right (▶) arrow button to select the preset you want to delete, and then press the **ENTER** button to implement the selection. You cannot delete the contents of the following presets: Power On Default, User Default, and Factory Default.

Network Information Submenu

This menu allows you to display all network parameters. Use the up (▲) or down (▼) arrow button to scroll through the menu. Figure 3-19 shows the Network information submenu diagram.

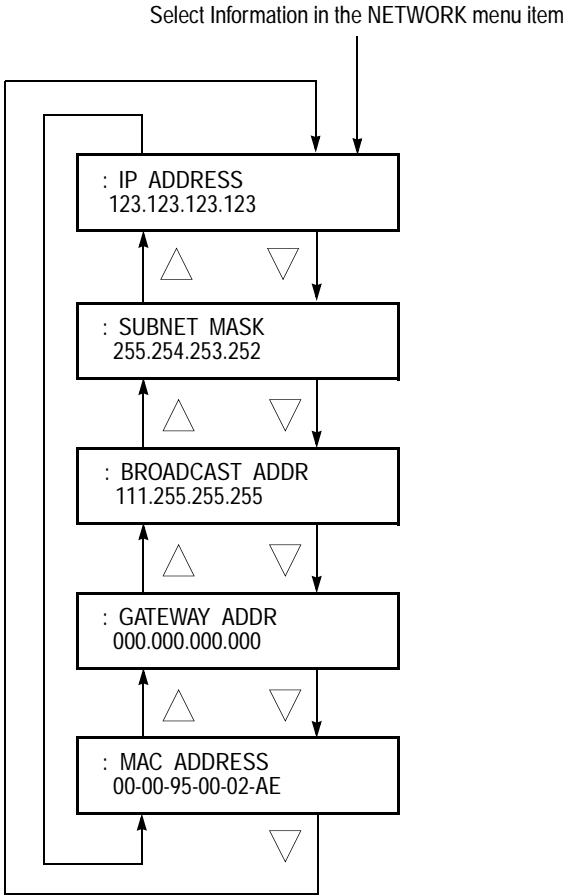

Figure 3-19: Network information submenu diagram

NOTE. A temporary IP address such as 10.xx.xx.xxx may appear on the IP ADDRESS display until the sync pulse generator receive an IP address from a DHCP server. If this happens, press the CANCEL button to exit the menu and then press the ENTER button to enter the menu again.

Network Setup Submenu

This menu allows you to set the sync pulse generator network parameters when connecting to a 100Base-T Ethernet. Use the up (▲) or down (▼) arrow button to scroll through the menu items. Figure 3-20 shows the Network setup submenu diagram.

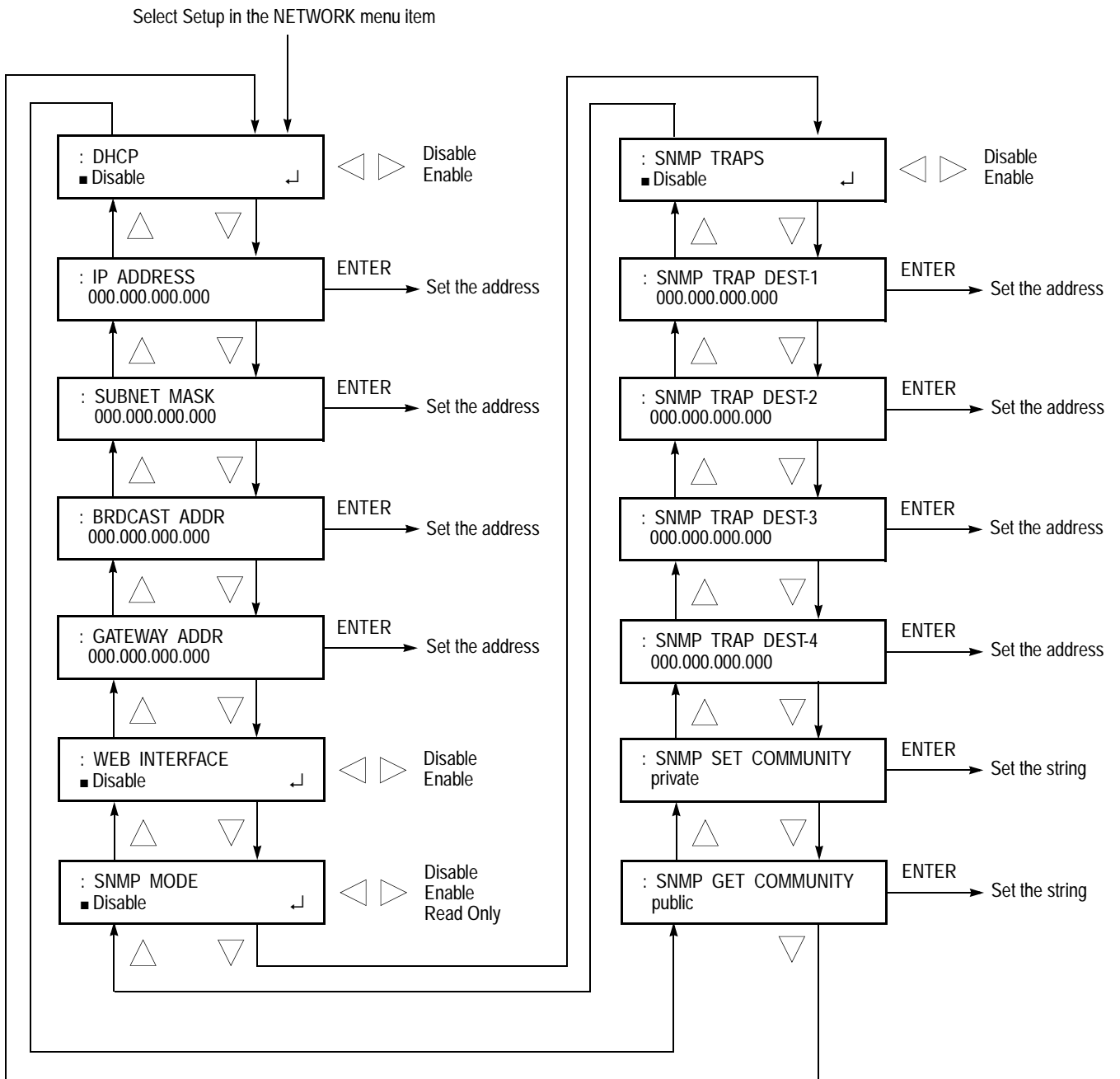

Figure 3-20: Network setup submenu diagram

DHCP. Enables or disables IP address settings by DHCP (Dynamic Host Configuration Protocol). Use the left (◀) or right (▶) arrow button to select between **Disable** and **Enable**. Press the **ENTER** button to implement the selection. If you select Disable in this menu, you will need to manually set network values for all of the network menu items.

Refer to the user documentation supplied with your server OS for detailed information about DHCP server functions.

NOTE. *Under some network environments, the sync pulse generator may not be able to get the IP address automatically from a DHCP server. In this case, you need to enter the appropriate address value in each submenu item.*

IP ADDRESS. Sets the IP address of the sync pulse generator. Press the **ENTER** button to edit the address. Then use the left (◀) or right (▶) arrow button to move the underscore character (_), and use the up (▲) or down (▼) arrow button to change the value. Press the **ENTER** button to enable the value. When no value is set, the default value is used. If the DHCP menu item is set to Enable, the sync pulse generator uses the IP address automatically obtained from the DHCP server.

SUBNET MASK. Sets the subnet address of the sync pulse generator. Press the **ENTER** button to edit the address. Then use the left (◀) or right (▶) arrow button to move the underscore character (_), and use the up (▲) or down (▼) arrow button to change the value. Press the **ENTER** button to enable the value. When no value is set, the default value is used. If the DHCP menu item is set to Enable, the sync pulse generator uses the subnet address automatically obtained from the DHCP server.

BRDCAST ADDR. Sets the broadcast address of the sync pulse generator. Press the **ENTER** button to edit the address. Then use the left (◀) or right (▶) arrow button to move the underscore character (_), and use the up (▲) or down (▼) arrow button to change the value. Press the **ENTER** button to enable the value. If the DHCP menu item is set to Enable, the sync pulse generator uses the broadcast address automatically obtained from the DHCP server.

GATEWAY ADDR. Sets the gateway address of the sync pulse generator. Press the **ENTER** button to edit the address. Then use the left (◀) or right (▶) arrow button to move the underscore character (_), and use the up (▲) or down (▼) arrow button to change the value. Press the **ENTER** button to enable the value.

WEB INTERFACE. Enables or disables web browser access to remotely control the sync pulse generator. Use the left (◀) or right (▶) arrow button to select between **Disable** and **Enable**. Press the **ENTER** button to confirm the selection. Refer to *Appendix B: Using the Remote Interface* for detailed information on how to use a web browser for controlling the instrument.

SNMP MODE. Enables or disables remote control access to the sync pulse generator over a network. Use the left (◀) or right (▶) arrow button to select **Disable**, **Enable**, or **Read Only**. When Enabled is selected, you can change instrument settings using SNMP management software. When Read Only is selected, you can only view instrument settings using SNMP management software. Press the **ENTER** button to confirm the selection.

SNMP TRAPS. Enables or disables sending SNMP traps from the sync pulse generator to an NMS (Network Management Station)(s). Use the left (◀) or right (▶) arrow button to select between **Disable** and **Enable**. When enabled, SNMP traps are sent to the NMS(s) specified by the destination address. Press the **ENTER** button to confirm the selection.

SNMP TRAP DEST-1 to 4. Sets the IP address of the NMS to which SNMP traps are sent. Press the **ENTER** button to edit mode the address. Then use the left (◀) or right (▶) arrow button to move the underscore character (_), and use the up (▲) or down (▼) arrow button to change the value. Press the **ENTER** button to enable the value.

SNMP SET COMMUNITY. Sets the string that SNMP commands must includes to have read/write access. Press the **ENTER** button to enter the edit mode to type the string. Then use the left (◀) or right (▶) arrow button to move the underscore character (_), and use the up (▲) or down (▼) arrow button to change the character. After you enter the string press the **ENTER** button to enable the value.

The default SNMP set community string is “private”.

SNMP GET COMMUNITY. Sets the string that SNMP commands must include to have read-only access. Press the **ENTER** button to enter the edit mode to type the string. Then use the left (◀) or right (▶) arrow button to move the underscore character (_), and use the up (▲) or down (▼) arrow button to change the character. After you enter the value press the **ENTER** button to enable the string.

The default SNMP get community string is “public”.

GPI Submenu This menu allows you to enable or disable the alarm signal output, reset alarm signal output, and display the alarm status. Use the up (▲) or down (▼) arrow button to scroll through the menu. Figure 3-21 shows the GPI submenu diagram.

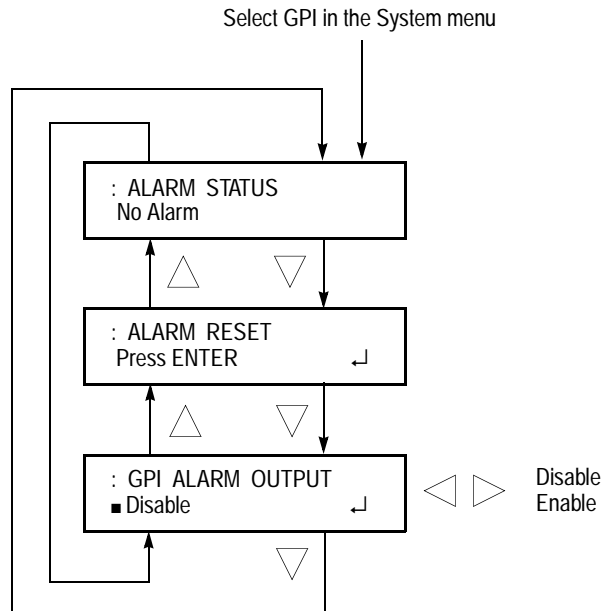

Figure 3-21: GPI submenu diagram

ALARM STATUS. Displays the alarm status detected inside the instrument. The possible alarm status messages:

NOTE. *In the alarm status display, the instrument alarm status shows the last-displayed error message. To display the latest message, press the CANCEL button and return to the ALARM STATUS menu.*

- **No Alarm:** No errors have been detected.
- **Genlock: Near Loss of Lock:** The frequency of the genlock signal and the internal reference signal shift considerably, and the sync pulse generator seems to be near loss of lock. If this happens, check the frequency of the genlock signal or internal reference signal of the sync pulse generator.
- **Genlock: Loss of Lock:** The sync pulse generator can not lock to a genlock signal.
- **Genlock: No Signal:** The sync pulse generator does not detect a valid genlock signal.

ALARM RESET. Resets the alarm status. The sync pulse generator holds the alarm status even if the cause of the alarm is eliminated. Use this menu item when you need to reset the status. If the cause of the error is not eliminated, the alarm status is set again when you reset the status.

GPI ALARM OUTPUT. Enables or disables the alarm signal output. Use the left (◀) or right (▶) arrow button to select between **Disable** and **Enable**. When enabled, an alarm signal is output on pin 1 of the GPI connector. Press the **ENTER** button to confirm the selection.

System Information Submenu

This menu allows you to display the system information. Use the up (▲) or down (▼) arrow button to scroll through the menu. Figure 3-22 shows the System information submenu diagram.

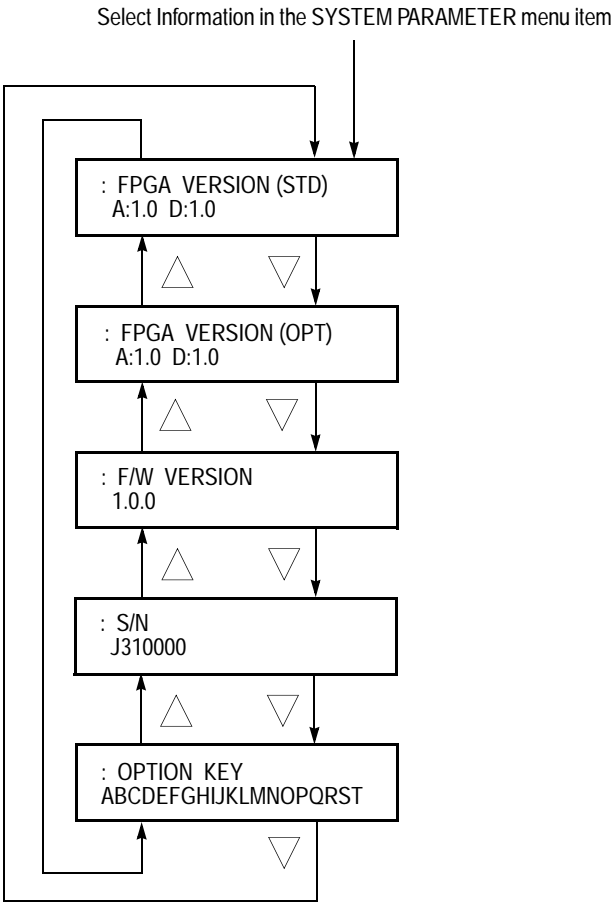

Figure 3-22: System information submenu diagram

FPGA VERSION (STD). Displays the FPGA version of the instrument circuit boards.

FPGA VERSION (OPT). Displays the FPGA version of the circuit board if option 02 or/and 03 are installed in the SPG600.

NOTE. *In the FPGA VERSION display, the letter M represents the Main board, A represents the analog output board, and D represents the SDI output board.*

F/W VERSION. Displays the instrument firmware version.

S/N. Displays the instrument serial number.

OPTION KEY. Displays the option key number for installed instrument options. Refer to the following text for a description of how to enter an option key.

System Setup Submenu

This menu allows you to enter the option key that enables the fine timing offset feature (Option 01). Figure 3-23 shows the System setup submenu diagram.

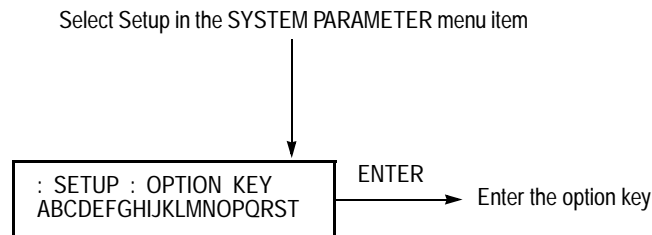

Figure 3-23: System setup submenu diagram

To enable the fine timing offset feature:

1. Contact your local Tektronix office to order Option 01. You will receive an option key (alphanumeric code).
2. Enter the option key using the following steps:
 - a. Press the **ENTER** button to enable the text entering mode. The underscore character (**_**) appears at the far left of the second line.
 - b. Use the up (**▲**) or down (**▼**) arrow button to select a character.
 - c. Use the right (**▶**) arrow button to move the underscore character and then use the up (**▲**) or down (**▼**) arrow button to select the character.
 - d. Repeat step c until all of the alphanumeric code is entered.
 - e. Press the **ENTER** button to end the text entering process.

If you enter an invalid option key for your instrument, the error message * **BAD OPTION KEY** * appears in the display. Press the CANCEL button and then repeat step 2.

Configuration Submenu

This menu allows you to select the video standard for the output signals and configure the output connectors. Use the up (▲) or down (▼) arrow button to scroll through the menu. Figure 3-24 shows the Configuration submenu diagram.

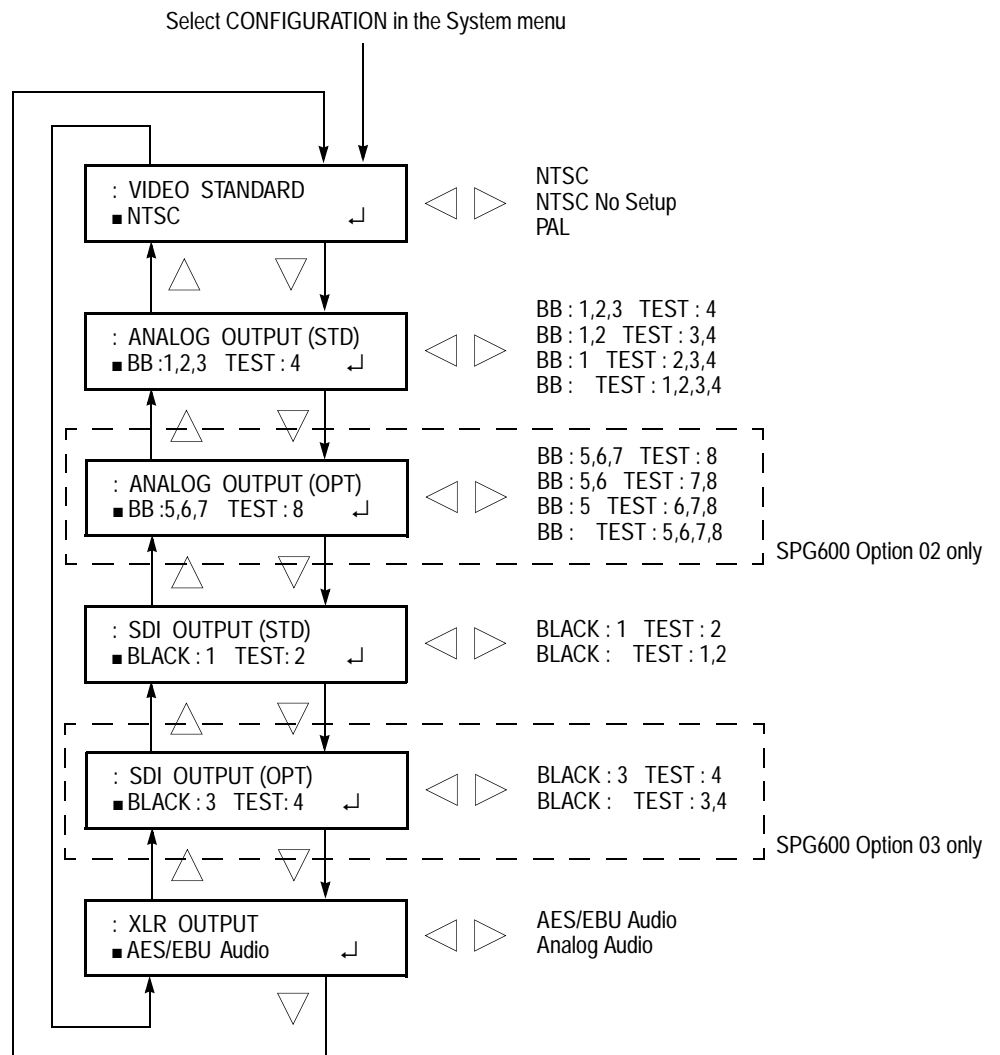

Figure 3-24: Configuration submenu diagram

VIDEO STANDARD. Sets the video standard for the outputs. Use the left (◀) or right (▶) arrow button to make the selection. You can select from the following options:

- **NTSC:** NTSC for the analog outputs and 525-270 for the serial digital outputs.
- **NTSC No Setup:** NTSC no setup for the analog outputs and 525-270 for the serial digital outputs.
- **PAL:** PAL for the analog outputs and 625-270 for the serial digital outputs.

Press the **ENTER** button to confirm the selection

ANALOG OUTPUT (STD). Sets the output configuration for the analog outputs (CH1 to CH4). Use the left (◀) or right (▶) arrow button to make the selection. You can select the following configurations:

- **BB:1,2,3 TEST: 4:** Black burst signals are output from the CH1, CH2, and CH3 connectors, and a test signal is output from the CH4 connector.
- **BB:1,2 TEST: 3,4:** Black burst signals are output from the CH1, and CH2 connectors, and test signals are output from the CH3 and CH4 connectors.
- **BB:1 TEST: 2,3,4:** A black burst signal is output from the CH1 connector, and test signals are output from the CH2, CH3, and CH4 connectors.
- **BB: TEST: 1,2,3,4:** Test signals are output from the CH1, CH2, CH3, and CH4 connectors.

Press the **ENTER** button to confirm the selection.

ANALOG OUTPUT (OPT). Sets the output configuration for the optional analog outputs (CH5 to CH8). Use the left (◀) or right (▶) arrow button to make the selection. You can select the following configuration:

- **BB:5,6,7 TEST: 8:** Black burst signals are output from the CH5, CH6, and CH7 connectors, and a test signal is output from the CH8 connector.
- **BB:5,6 TEST: 7,8:** Black burst signals are output from the CH5, and CH6 connectors, and test signals are output from the CH7 and CH8 connectors.
- **BB:5 TEST: 6,7,8:** A black burst signal is output from the CH5 connector, and test signals are output from the CH6, CH7, and CH8 connectors.
- **BB: TEST: 5,6,7,8:** Test signals are output from the CH5, CH6, CH7, and CH8 connectors.

Press the **ENTER** button to confirm the selection.

SDI OUTPUT (STD). Sets the output configuration for the digital serial outputs (SDI 1 and SDI 2). Use the left (◀) or right (▶) arrow button to make the selection. You can select the following configurations:

- **BLACK:1 TEST:2:** A serial digital black signal is output from the SDI 1 connector, and a serial digital test signal is output from the SDI 2 connector.
- **BLACK: TEST:1,2:** Serial digital test signals are output from the SDI 1 and SDI 2 connectors.

Press the **ENTER** button to confirm the selection.

SDI OUTPUT (OPT). Sets the output configuration for the optional digital serial outputs (SDI 3 and SDI 4). Use the left (◀) or right (▶) arrow button to make the selection. You can select the following configurations:

- **BLACK:3 TEST:4:** A serial digital black signal is output from the SDI 3 connector, and a serial digital test signal is output from the SDI 4 connector.
- **BLACK: TEST:3,4:** Serial digital test signals are output from the SDI 3 and SDI 4 connectors.

Press the **ENTER** button to confirm the selection.

XLR OUTPUT. Sets the output configuration for the XLR audio outputs (1+2/RIGHT and 3+4/LEFT). Use the left (◀) or right (▶) arrow button to make the selection. You can select the following configurations:

- **AES/EBU Audio:** AES/EBU digital audio signals are output from the 1+2/RIGHT and 3+4/LEFT connectors.
- **Analog Audio:** Analog audio signals are output from the 1+2/RIGHT and 3+4/LEFT connectors.

Press the **ENTER** button to confirm the selection.

Using the General Purpose Interface (GPI)

The sync pulse generator has a 9-pin, D-type connector that can be used as a General Purpose Interface (GPI). When using the GPI connector, you can recall one of the seven presets, output an alarm signal, and display an alarm status on the display.

GPI Connector Pin Assignments

Figure 3-25 shows the pin assignments of the GPI connector. Pin 1 is used to output an alarm signal. Pins 3, 4, and 5 are used to input signals for recalling a preset.

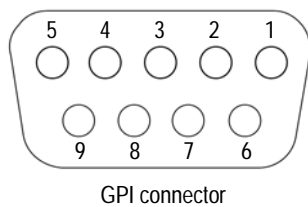

Pin	Description	Notes
1	Output	Low < 0.4 V or ground (when drawn 100 mA; maximum 4 Ω)
2	Unused	-----
3	Input	High > 1.4 V or open (connected to an internal 10 k Ω pull-up resistor) Low < 0.4 V or ground (input impedance: 10 k Ω)
4	Input	
5	Input	
6	Ground	-----
7	Reserved	-----
8	Reserved	-----
9	Ground	-----

Figure 3-25: Pin assignments of the GPI Connector



CAUTION. Do not connect any wires to pin 7 and 8. Doing so can result in damage to the instrument.

Figure 3-26 shows the input/output circuit of GPI.

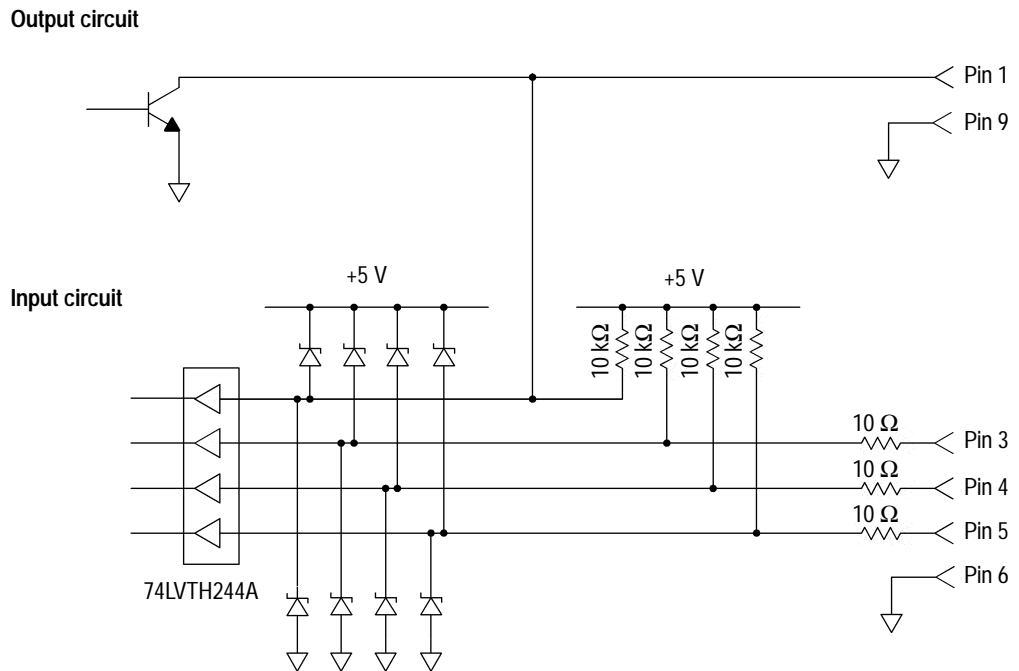

Figure 3-26: Input/output circuit of GPI

Recalling a Preset

You can recall one of the seven presets by combinations of signal levels on pins 3, 4, and 5 of the GPI connector. Table 3-7 shows the combinations of signal levels for the pins and the preset number to be recalled.

Table 3-7: Combinations of signal levels and the corresponding preset

Pin 3	Pin 4	Pin 5	Preset number
Low	High	High	1
High	Low	High	2
Low	Low	High	3
High	High	Low	4
Low	High	Low	5
High	Low	Low	User Default
Low	Low	Low	Factory Default

All of the input signals are active low; when the signal level for the specified pin(s) goes from High to Low, the corresponding preset is recalled. For example, when the signal level for pin 5 goes from High to Low, the preset 1 is recalled.

NOTE. *The instrument does not detect signal transitions on the edge of the signal. The signal level needs to hold for about 0.5 seconds to recall a preset, and then the settings of the instrument change. The required time to change the settings depends on the contents of a preset.*

Outputting an Alarm Signal

The instrument can output an alarm signal from pin 1 on the GPI connector when one of the following internal errors occur:

- When a genlock signal is not connected.
- When the sync pulse generator does not lock to a genlock signal.
- When the frequency of the genlock signal and internal reference shift considerably, and the sync pulse generator seems to be near loss of lock.

The output signal is active low; the signal level for pin 1 goes High to Low when any errors occur.

Use the GPI menu item in the System menu to enable alarm signal output. Refer to *GPI Submenu* on page 3-34 for more information.

Factory Default Settings

Table 3-8 lists the instrument factory default settings. These settings can be recalled by selecting **Factory Default** from the **PRESET : RECALL** menu item in the System menu.

Table 3-8: Factory default settings

Menu item name	Settings
Video menu	
ANALOG SYNC (STD)	Black Burst
ANALOG SYNC (OPT)	Black Burst
TEST SIGNAL (ANALOG)	SMPTE Color Bars
TEST SIGNAL (SDI)	SMPTE Color Bars
TIMING (ANALOG)	
VERTICAL	0 Line
HORIZONTAL	0.0000 μ sec
FINE (Option 01 only)	0.0 nsec
TIMING (SDI)	
VERTICAL	0 Line
HORIZONTAL	0.0000 μ sec
OVERLAY	
Blink	OFF
OVERLAY: LOGO	
Logo	OFF
X	0.0 %APH
Y	0.0 %APH
OVERLAY: ID TEXT	
Status	Disable
X	10.0 %APH
Y	80.0 %APH
PARAMETER	
COMPONENT	Y, Cb, Cr
PRECISION	10-bit
EDH	Enable

Table 3-8: Factory default settings

Menu item name	Settings
Audio menu	
AES/EBU	
Freq.	1000 Hz
Ampl.	-20.0 dBFS
Audio Click	OFF
Emphasis	NO
Resolution	20 bits
Delay	0.0 µsec
EMBEDDED	
Status	Disable
Freq.	1000 Hz
Ampl.	-20.0 dBFS
Audio click	OFF
Emphasis	NO
Sync	Frame
Resolution	20 bits
ANALOG	
Channel	Left
Freq.	1000 Hz
Ampl.	0.0 dBu
Audio Click	OFF
Genlock menu	
GENLOCK SOURCE	Internal
GENLOCK TIMING	
VERTICAL	0 Line
HORIZONTAL	0.0000 µsec
FINE	0.0 nsec
LOCK LOSS ACTION	Internal Mode
System menu	
NETWORK	
DHCP	Disable
WEB INTERFACE	Disable
SNMP MODE	Disable
SNMP TRAPS	Disable
SNMP GET COMMUNITY	public
SNMP SET COMMUNITY	private
GPI	
ALARM OUTPUT	Disable

Table 3-8: Factory default settings

Menu item name	Settings
CONFIGURATION	
VIDEO STANDARD	NTSC
ANALOG OUTPUT (STD)	BB:1,2,3 TEST: 4
ANALOG OUTPUT (OPT)	BB: 5,6,7 TEST: 8
SDI OUTPUT (STD)	BLACK: 1 TEST: 2
SDI OUTPUT (OPT)	BLACK: 3 TEST: 4
XLR OUTPUT	AES/EBU Audio



Appendices

Appendix A: Specifications

This section lists the electrical, mechanical, and environmental characteristics, as well as the national and international standards to which the Sync Pulse Generator complies.

General Characteristics

This section lists the electrical, mechanical, and environmental characteristics of the Sync Pulse Generator.

All listed specifications are guaranteed unless labeled with typical. Typical specifications are provided for your convenience but are not guaranteed.

Performance Conditions

The electrical characteristics listed on the following pages are valid under the following conditions:

- The Sync Pulse Generator must be in an environment where the temperature, altitude, humidity, and vibration conditions are within the operating limits described in Table A-11 on page A-9.
- The Sync Pulse Generator must have a warm-up period of at least 20 minutes.
- The Sync Pulse Generator must have been calibrated and adjusted at an ambient temperature between +20 °C and +30 °C.

Table A-1: Reference Inputs

Characteristic	Performance requirement	Reference information
Input connector type	75 Ω BNC X 2, loophrough	
Return loss	> 40 dB to 5 MHz	
Genlock inputs	NTSC Burst 525 Sync PAL Burst PAL Sync CW 1 MHz, 5 MHz, NTSC Burst, PAL Burst, and 10 MHz	
Input requirements		
Reference inputs		
Amplitude	-6 dB to 6 dB	
S/N ratio	> 40 dB	
SCH phase	40 °	
CW amplitude	1 to 2.5 Vp-p	
Pull-in range	\pm 5 ppm	
Jitter		
Burst	< 0.5 °	
Sync	< 1 ns	
Genlock time offset range		
Range	Full color frame	
Resolution	< 0.5 degree of subcarrier	

Table A-2: Analog outputs (standard and Option 02)

Characteristic	Performance requirement	Reference information
Output connector type	BNC	
Number of outputs		
Standard	4	CH1 to CH4
Option 02 (SPG600 only)	8	CH1 to CH8
Output impedance	75 Ω	
Return loss	> 30 dB to 5 MHz	
Formats		NTSC, NTSC No Setup, and PAL
Burst amplitude accuracy	\pm 5%	
Burst frequency accuracy	\pm 1 Hz of burst frequency	
Burst frequency long term	< 1 ppm/year	
Sync amplitude accuracy	\pm 3%	
Blanking level	\pm 50 mV	
SCH phase accuracy	\pm 5 °	

Table A-2: Analog outputs (standard and Option 02) (cont.)

Characteristic	Performance requirement	Reference information
Timing offset		
Range	Full color frame	
Resolution	< 1/27 MHz	
Output signals		
NTSC and NTSC No Setup		Refer to Table 3-2 on page 3-7.
PAL		Refer to Table 3-2 on page 3-7.
ID text	Maximum 20 characters	Blanking interval: 1 s, 2 s, 3 s, or off
Logo	Gray scale, 4 level	Blanking interval: 1 s, 2 s, 3 s, or off

Table A-3: Serial digital interface (standard and Option 03)

Characteristic	Performance requirement	Reference information
Output connector type	BNC	
Number of outputs		
Standard	2	SDI 1 and SDI 2
Option 03 (SPG600 only)	4	SDI 1, SDI 2, SDI 3, and SDI 4
Output impedance	75 Ω	
Return loss	> 15 dB	
Formats		525-270, 625-270 (270 Mbps)
Signal amplitude, typical	800 mV \pm 10%	
Rise and fall time	0.4 ns to 1.5 ns	20% to 80%
Jitter, typical	< 0.2 UI	
Embedded audio		The settings of the channels 9 to 16 are a copy of those of the channels 1 to 8.
Number of channels	16 (4 groups)	
Frequency	Silence to 20 kHz	31 discrete settings
Level	-60 dBFS to 0 dBFS	1 dB resolution
Preemphasis	None, CD, and FCC	
Click	1 s, 2 s, 3 s, 4 s, and Off	
Timing offset		
Range	Full color frame	
Resolution	< 1/27 MHz	
Output signals		
525-270		Refer to Table 3-3 on page 3-10.
625-270		Refer to Table 3-3 on page 3-10.
ID text	Maximum 20 characters	Blanking interval: 1 s, 2 s, 3 s, or off
Logo	Gray scale, 4 level	Blanking interval: 1 s, 2 s, 3 s, or off

Table A-4: AES/EBU audio outputs

Characteristic	Performance requirement	Reference information
Output connector type		
SPG600	75 Ω BNC: 4, XLR: 2	
SPG300	XLR: 2	
Number of outputs		
SPG600	8	1+2, 3+4, 5+6, and 7+8
SPG300	4	1+2 and 3+4
Quantized resolution		20 or 24 bits (user selectable)
Audio parameters		
Frequency	Silence to 20 kHz	31 discrete settings
Level	-60 dBFS to 0 dBFS	1 dB resolution
Preemphasis	None, CD, and FCC	
Click	1 s, 2 s, 3 s, 4 s, and Off	
Output level	1 V \pm 0.1 V 5 V \pm 0.3 V	Terminated 75 Ω unbalanced to BNC Terminated 110 Ω balanced to XLR
Required receiver termination	75 Ω \pm 10% for unbalanced to BNC 110 Ω \pm 10% for balanced to XLR	
Rise and fall time	30 ns to 44 ns 5 ns to 30 nS	10% to 90% to BNC 10% to 90% to XLR
Jitter	\pm 8 ns	
Timing offset		
Range	160 ms	
Resolution	1 μ s	
Word clock		
Connector	BNC	
Frequency	48 kHz	
Level	CMOS compatible	
Impedance	75 Ω \pm 10%	

Table A-5: Analog audio outputs

Characteristic	Performance requirement	Reference information
Output connector type	XLR	
Number of channels	2	1+2/RIGHT and 3+4/LEFT
Output impedance	12 Ω	
Audio parameters		
Frequency	Silence to 20 kHz	31 discrete settings
Level	-48 dBu to 12 dBu	1 dB resolution
Click	1 s, 2 s, 3 s, 4 s, and Off	

Table A-6: GPI (general purpose interface)

Characteristic	Performance requirement	Reference information
Output connector type		D-sub, 9 pin
Outputs	Pin 1: Error output (go to low when an error occurs) Pin 9: GND	
Output level	< 0.4 V	Measured at 100 mA sink or maximum 4 Ω
Inputs	Pin 3: Input 1 Pin 4: Input 2 Pin 5: Input 3 Pin 6: GND	Active low input
Input level	TTL compatible	Inputs are pulled up with 10 k Ω

Table A-7: SNMP error report

Characteristic	Performance requirement	Reference information
Protocol		SNMP v1, v2c
Alarm		The same alarm as the GPI will be reported.
Status		Serial number, firmware and hardware version, hardware configuration/option, etc.

Table A-8: AC power source

Characteristic	Performance requirement	Reference information
Rating voltage		100 V to 240 V, 50/60 Hz
Voltage range		90 V to 250 V, 50/60 Hz
Power consumption		SPG600: 85VA, 35W SPG300: 65VA, 30W
Surge current		< 20 A: SPG600 and SPG300

Table A-9: Clearance

Characteristic	Performance requirement	Reference information
Side		5 cm (2 in)
Rear		7.5 cm (3 in)

Table A-10: Mechanical characteristics

Characteristic	Description
SPG600	
Dimensions	See Figure A-1.
Height	43.6 mm (1.7 in)
Width	482.5 mm (19.0 in)
Depth	557.5 mm (21.9 in)
Net weight	Approximately 6 kg (with rack rail)
SPG300	
Dimensions	See Figure A-2.
Height	43.6 mm (1.7 in)
Width	206.2 mm (8.1 in)
Depth	435.7 mm (17.2 in)
Net weight	Approximately 2.5 kg

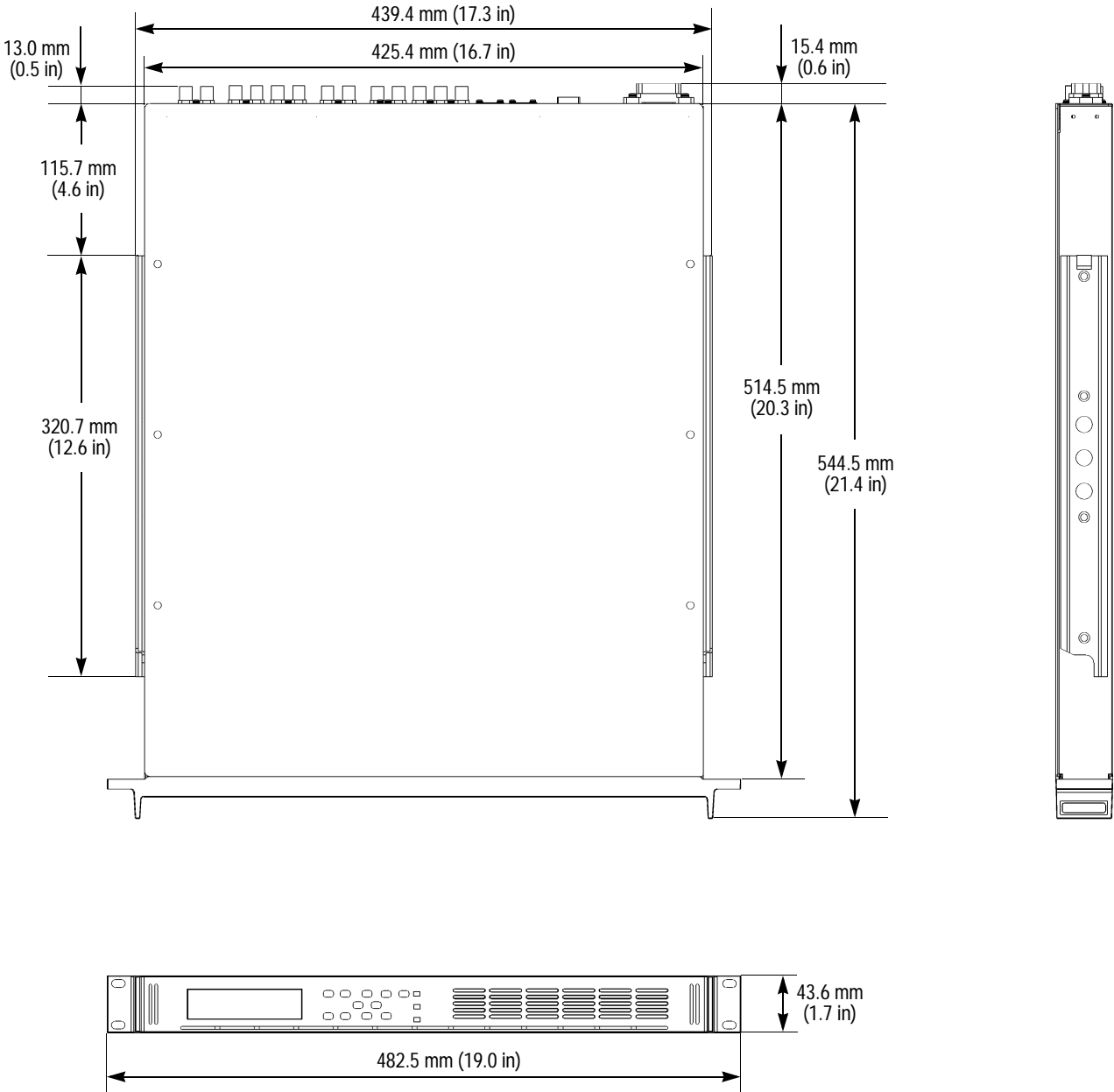

Figure A-1: SPG600 dimensions

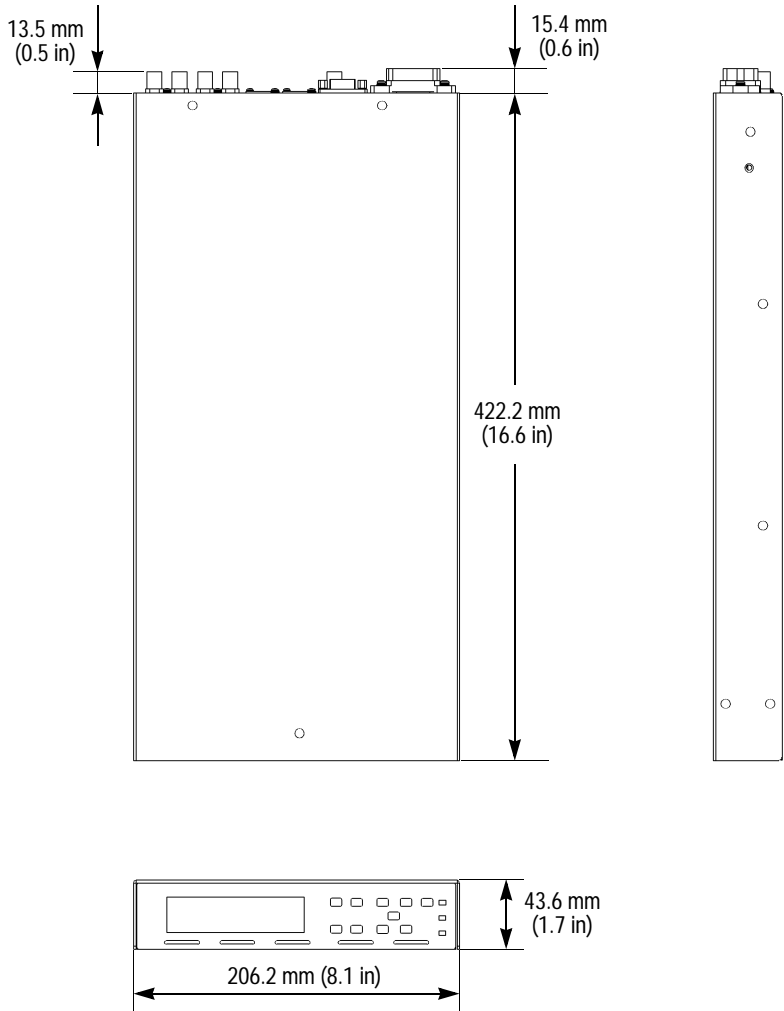

Figure A-2: SPG300 dimensions

Table A-11: Environment characteristics

Characteristic	Description
Temperature	
Operating	0 °C to +40 °C
Nonoperating	-20 °C to +60 °C
Relative humidity	
Operating	20% to 80% relative humidity (% RH) at up to +40 °C, noncondensing.
Nonoperating	5% to 90% relative humidity (% RH) at up to +60 °C, noncondensing.
Attitude	
Operating	To 3,000 m (10,061 feet)
Nonoperating	To 12,192 m (40,000 feet)
Vibration	
Operating	2.65 m/s ² (0.27 Grms), 5 Hz to 500 Hz, 10 minnutes per axis, three axes.
Nonoperating	22.3 m/s ² (2.28 Grms), 5 Hz to 500 Hz, 10 minnutes per axis, three axes.
Shock	
Nonoperating	294 m/s ² (30 G), half-sine, 11 ms duration.

Table A-12: Certifications and compliances (cont.)

Category	Standards or description
Pollution Degree	<p>A measure of the contaminants that could occur in the environment around and within a product. Typically the internal environment inside a product is considered to be the same as the external. Products should be used only in the environment for which they are rated.</p> <p>Pollution Degree 2 Normally only dry, nonconductive pollution occurs. Occasionally a temporary conductivity that is caused by condensation must be expected. This location is a typical office/home environment. Temporary condensation occurs only when the product is out of service.</p>
IEC Characteristics	<p>Equipment type:</p> <p>Test and Measuring</p> <p>Installation Category II (as defined in IEC 61010-1, Annex J)</p> <p>Pollution Degree 2 (as defined IEC 61010-1)</p> <p>Safety Class I (as defined in IEC 61010-1, Annex H)-ground product</p> <p>Temperature 5 °C to 40 °C</p>

Appendix B: Using the Remote Interface

The sync pulse generator can be accessed two ways over an Ethernet network: using a Web browser or by running a Java applet. If you install Java on your PC, you can use a Java applet to change the instrument settings and to upload and download presets and logos. The Java applet provides a control window that gives you complete control over instrument settings from a remote PC.

Using a Web Browser

You can use a Web browser to connect to the sync pulse generator and perform simple operations without installing any. To use a Web browser, the sync pulse generator must be connected to a local area network via Ethernet. You will need to set the IP address, subnet mask, and possibly the gateway address, depending on your network configuration. For information on how to set the network parameters, refer to *Network Setup Submenu* on page 3-30.

To use a Web browser to connect to the sync pulse generator:

1. Press the **SYSTEM** button to enter the System menu.
2. Press the up (▲) or down (▼) arrow button to select **NETWORK**.
3. Press the left (◀) or right (▶) arrow button to select **Setup** and then press the **ENTER** button.
4. Press the up (▲) or down (▼) arrow button to select **WEB INTERFACE**.
5. Press the left (◀) or right (▶) arrow button to select **Enable** and then press the **ENTER** button.
6. Start your Web browser and type the network address of the sync pulse generator into the URL entry box. For example:

```
http://117.117.898.898/
```

NOTE. Many web browsers do not correctly interpret leading zeros in IP addresses. If the IP address shown in the Configuration menu contains leading zeros, such as in 134.151.037.251, remove the “0” when entering it into the address line of the browser. For example, 134.151.037.251 should be entered as 134.151.37.251.

Figure B-1 shows a Web browser window when you access the remote interface.

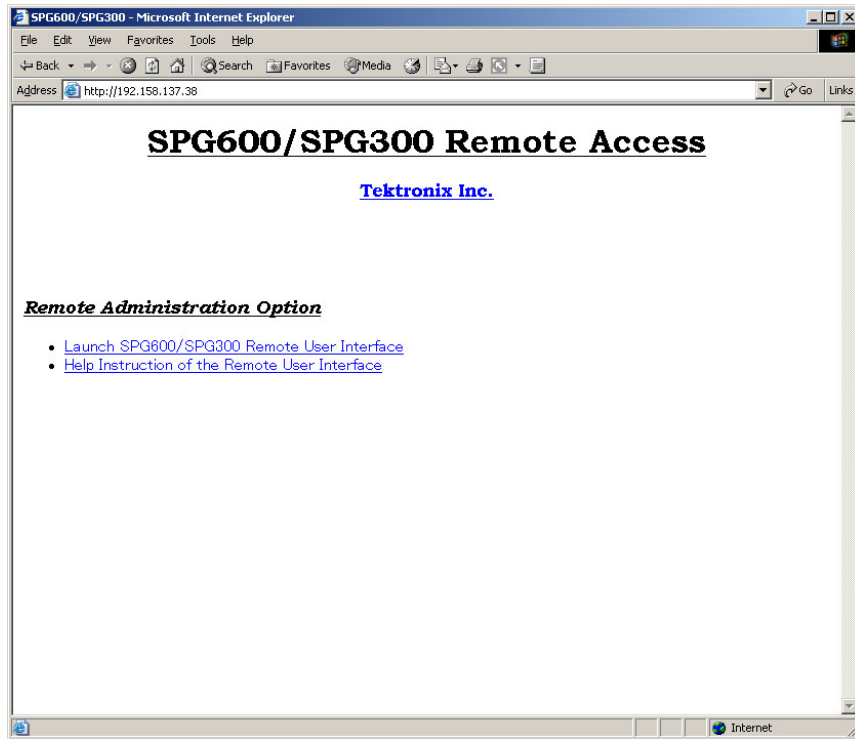

Figure B-1: Accessing the remote interface using a Web browser

Table B-1 shows the function of each link displayed in the Web browser window.

Table B-1: Web browser interface functions

Selection	Description
Launch SPG600/SPG300 Remote User Interface	Starts Java applet for the sync pulse generator remote user interface.
Help Instruction of the Remote User Interface	Displays the help documentation about the Java applet window.

Using the Java Applet for the Remote Interface

The Java applet version of the remote interface lets you change any setting on the sync pulse generator. You can also upload and download preset and logo files.

Browser Requirements

The Java applet is only supported for Microsoft Internet Explorer 5.0 or later running on a Microsoft Windows PC. The Java applet window does not resize correctly when run in Netscape 6.0 (all platform) or Safari 1.0 on Mac OS X. The web applet is not supported in Netscape versions prior to version 6.0 and/or any version of Internet Explorer on Mac OS X because they do not support Java version 1.41.

Installing Java

To run the Remote Interface Java applet, you must have Version 1.41 (or later) of the Java Run-Time Environment (JRE) from Sun Microsystems installed on your PC. To download the JRE plug-in from Sun Microsystems, go to the following URL and download the appropriate code:

<http://java.sun.com/j2se/1.4/>

Once you download the executable file, launch the installation software and follow the instructions.

Launching the Java Applet

When you launch the Java applet, it is downloaded from the sync pulse generator and launched. There is no software installation required to use the applet (other than the Java Run-Time Environment noted previously).

To launch the Java applet:

1. Launch your Web browser and type the network address of the sync pulse generator into the URL entry box. For example:

http://117.117.898.898

NOTE. Many web browsers do not correctly interpret leading zeros in IP addresses. If the IP address shown in the Configuration menu contains leading zeros, such as in 134.151.037.251, remove the “0” when entering it into the address line of the browser. For example, 134.151.037.251 should be entered as 134.151.37.251.

Once you type the network address of the sync pulse generator, press Return to access the Remote Interface.

2. Select **Launch Applet** on the Web browser window. The Web browser launches the Java applet and display the screen shown in Figure B-2.

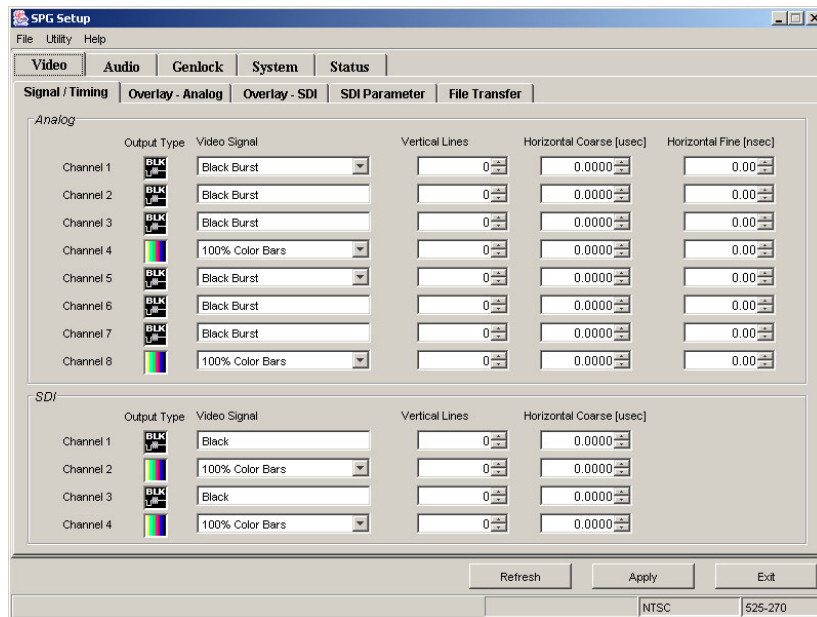

Figure B-2: Java applet

Elements of the Java Applet Window

The Java applet window contains a title bar, a menu bar, a parameter setting panel, a status bar, and three control buttons (see Figure B-3).

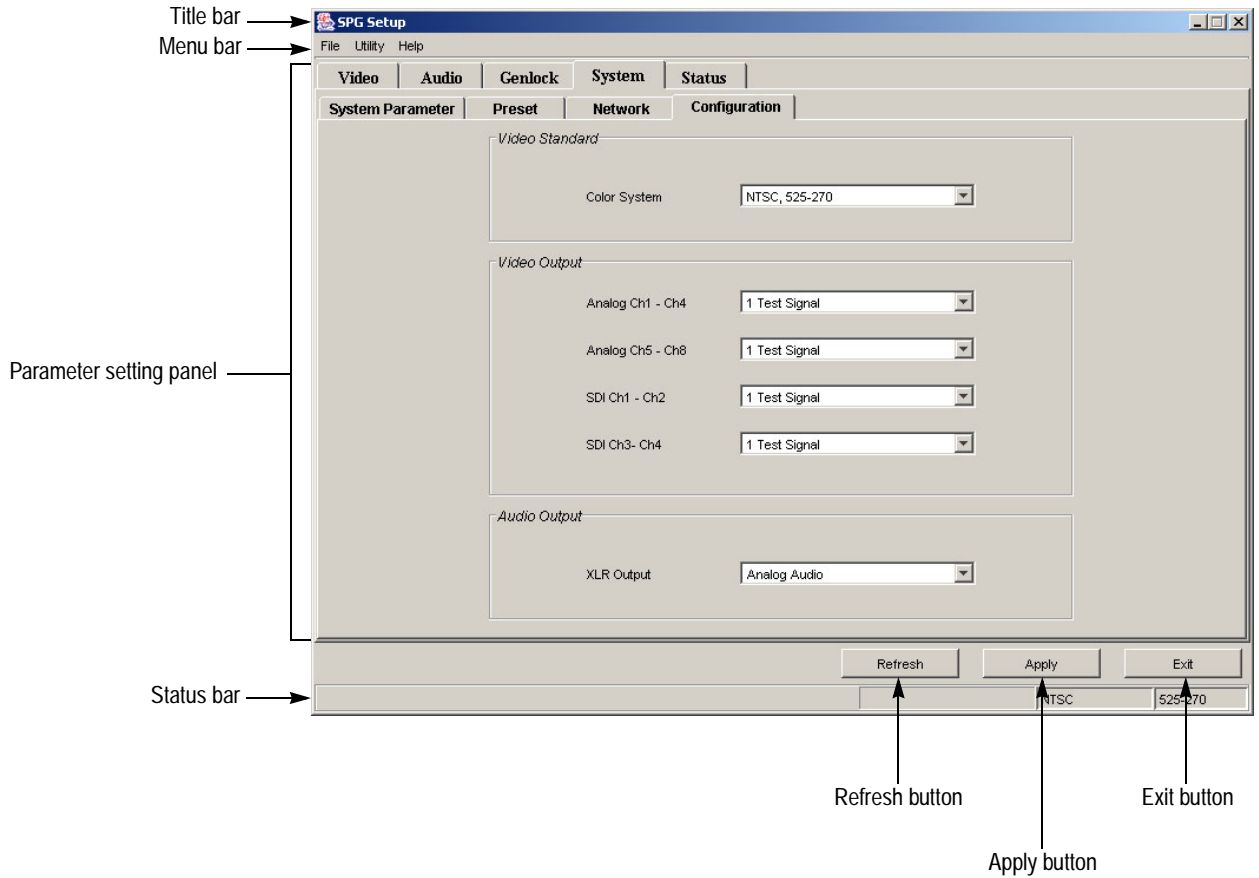

Figure B-3: Java applet window

- **Title bar:** The title bar displays the name of the application and contains the standard window-sizing buttons.
- **Menu bar:** The menu bar displays the name of the two pull-down menus. Refer to *Elements of the Menu Bar* on the following page for detailed information about the functions available in the menus.
- **Parameter setting panel:** Use this panel to set the instrument parameters. There are five main tabs. Use the Status tab to list all of the current parameter settings.
- **Refresh button:** Cancels any setting changes and restores the current instrument settings.

- **Apply button:** Enables all setting changes.
- **Exit button:** Exits the Java applet and returns to the Web browser window.
- **Status bar:** The status bar displays operating information and the video standard currently selected.

Elements of the Menu Bar

Table B-2 lists each of the Remote Interface menus and the commands within the menus.

Table B-2: Remote Interface menu

Menu	Commands	Description
File	Load Parameter	Loads an existing settings file saved in CSV format.
	Save Parameter	Saves current sync pulse generator settings as a CSV file.
	Exit	Exits the Java applet and returns to the Web browser window.
Utility	SNMP Community	Sets the string that SNMP commands must include to have read-only access (get community) or read/write access (set community). The default SNMP get community string is "public" and set community string is "private". You must set the same community string used by the sync pulse generator.
	Date and Time	Sets the date and time for the sync pulse generator.
	Option Key	Enters the option key that enables the fine timing offset feature (option 01).
Help	Help	Displays the help documentation about the Java applet window.
	About	Displays version information about the Remote Interface.

Changing Instrument Settings

This section explains how to use the Remote Interface to change the instrument settings. In this example, you will change the genlock settings.

Perform the following steps to change instrument settings:

1. Click the **Genlock** tab on the Java applet window. This opens the parameter setting fields for that tab (see Figure B-4).

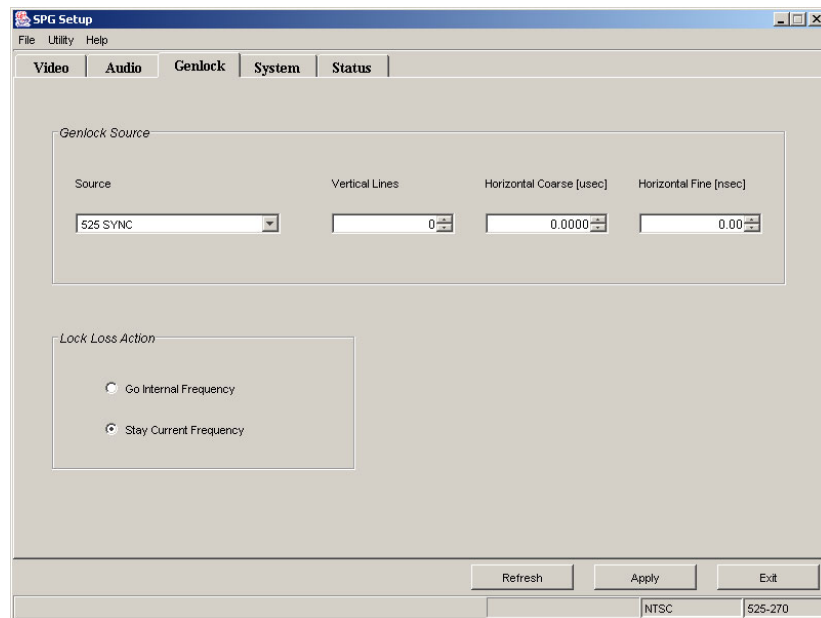

Figure B-4: Java applet window after selecting the Genlock tab

2. Click the **Source** list box to select a genlock source from the pull-down list.
If you select an item other than Internal, **Vertical Lines**, **Horizontal Coarse [μsec]**, and **Horizontal Fine [nsec]** setting boxes are enabled.
3. If you want to change the timing, enter a specific value or click the up or down arrow in the any of the boxes.
4. Click the option button that corresponds to the desired lock loss action: **Go Internal Frequency** or **Stay Current Frequency**.
5. Click the **Apply** button at the bottom of the window to enable the new settings.

Transferring Files

This section provides the procedure to use the Remote Interface to transfer files between your PC and the sync pulse generator.

NOTE. The convention used by the Remote Interface is to call file transfers from the PC to the sync pulse generator a “upload”, and to call file transfers from the sync pulse generator to the PC an “download”.

Uploading a File to the Sync Pulse Generator. Perform the following steps to upload a logo file or signal file (DNL file) from the PC to the sync pulse generator.

NOTE. Refer to Appendix C: Using Logo Generator for detailed information about creating a logo file.

For a logo file:

1. Click the **Video** tab on the Java applet window.
2. Click the **File Transfer** tab to open the setting panel for file transfers (see Figure B-5).

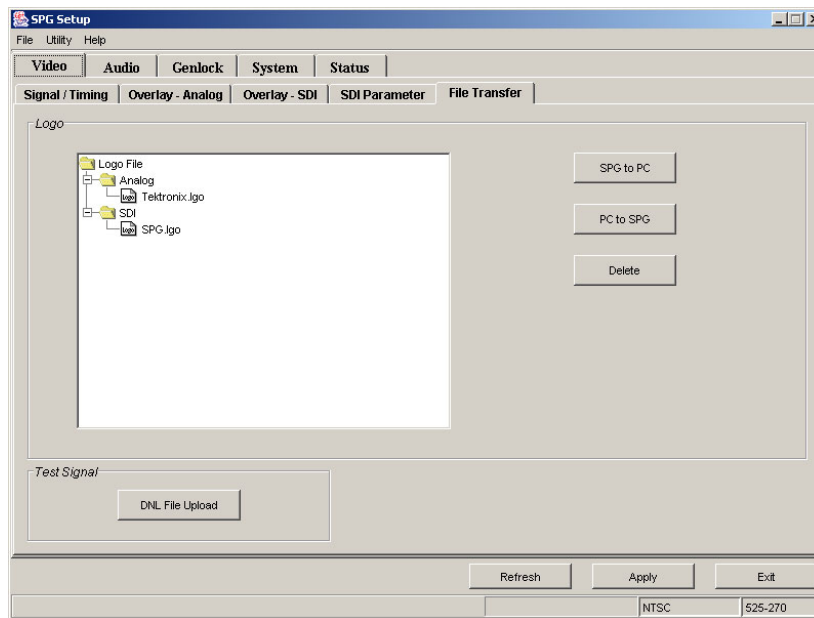

Figure B-5: File Transfer setting panel

3. Click the **PC to SPG** button. The **Select Logo Folder** dialog box appears as shown in Figure B-6.

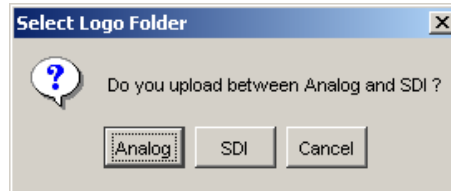

Figure B-6: Select Logo Folder dialog box

4. In the dialog box, select the destination folder for the logo file you are going to upload to the sync pulse generator. The **Open** dialog box appears.
5. In the dialog box, select the logo file (*.log) that you want to upload.
6. Click the **Open** button.

If you want to delete a existing logo file, select the logo file in the tree view and then click the **Delete** button.

For a signal file:



CAUTION. Do not upload or use any signal files from the TG700/TG2000 signal generator or created by the SDP2000 software. These signal files are not compatible with the sync pulse generator.

1. Click the **Video** tab on the Java applet window.
2. Click the **File Transfer** tab to open the setting panel for file transfers (see Figure B-5).
3. Click the **DNL File Upload** button. The **Open** dialog box appears.
4. In the dialog box, select the signal file (*.dnl) that you want to upload.
5. Click the **Open** button.

Downloading a Logo File to the PC. Perform the following steps to download a logo file from the sync pulse generator to the PC.

1. Click the **Video** tab on the Java applet window.
2. Click the **File Transfer** tab to open the setting panel for file transfers (see Figure B-5).
3. In the tree view on the Window, select the logo file (*.lgo) you want to download, and then click the **SPG to PC** button. The **Save As** dialog box appears.
4. In the dialog box, specify the destination folder for the logo file you are going to download to the PC.
5. Click the **Save** button.

Appendix C: Using Logo Generator

Logo Generator, a standard accessory with the sync pulse generator, is a Microsoft Windows software application. Logo Generator converts a Windows bitmap file (.bmp) to a logo file (.lgo) that can be used for the logo overlay feature of the sync pulse generator.

This section provides the following information:

- PC system requirement
- Installation instructions
- Starting and exiting Logo Generator
- Elements of Logo Generator window
- Using the Logo Generator menus
- Logo Generator tutorials

PC System Requirement

You can run Logo Generator on the following operating systems:

- Microsoft Windows 95/98/XP/2000/NT4.0

Installation Instructions

The following instructions install the Logo Generator application on your PC and create a desktop shortcut icon on the PC to run the application.

Installing Logo Generator

The following installation instructions assume that you are familiar with the basics of using the Windows operating system. If necessary, read your Windows user documentation before installing Logo Generator.

Perform the following procedure to install Logo Generator on your PC:

1. Insert the **SPG600 & SPG300 Application Software** CD into a CD-ROM drive on your PC.
2. Double-click the **My computer** icon.
3. Double-click the **CD-ROM drive** icon.

4. Double-click the **LogoGen** folder to display the contents of the LogoGen folder.



CAUTION. *To prevent data loss, it is strongly recommended that you exit any open applications on your PC before you run the Logo Generator Setup.exe file.*

5. Double-click the **SETUP.EXE** icon in the list. The Logo Generator installation program display a series of setup windows as listed below. Click the **Next>** button to accept the default parameters, or change the parameters in the setup windows to suit your needs. Click the **Back** button in a setup window to return to the previous setup window.
 - a. Welcome window. Read the displayed information, and then click the **Next** button to proceed with the installation.
 - b. Choose Destination Location window. The default directory location for the application is displayed. If you want to install it in a custom location, click the **Browse...** button, and then select or create a custom directory location.
 - c. Select Program Folder window. The default name for the program folder is displayed. If you want to change the name, type in a new name or select a name from the Existing Folders list. Click the **Next** button to proceed.
 - d. Start Copying Files window. Review the displayed information, and then click the **Next** button to start the installation.
 - e. Setup Complete window. If the installation is successful, you will see a message that setup has finished installing the Logo Generator application onto your PC. If you want to run Logo Generator immediately, select **Yes, Launch the program file**, and then click the **Finish** button. To exit the installation program without running Logo Generator, click the **Finish** button.
6. Remove the SPG600 & SPG300 Application Software CD from your PC, and then store the CD in a safe location.

Creating a Desktop Shortcut Icon

Perform the following procedure to create an icon on your PC desktop that you can use to run the Logo Generator application:

1. On your PC display, move the mouse cursor to any unoccupied desktop area, and then click the right mouse button to open the desktop menu.
2. From the desktop menu select **New**, and then select **Shortcut** to open the Create Shortcut dialog box.
3. Click the **Browse...** button in the Create Shortcut dialog box.

4. Use the Browse dialog box to locate the Logo Generator directory.
 - a. If you installed the Logo Generator application using the default directory location and the default folder name, navigate the following directory folders in order: **Program Files**, **Tektronix**, **SPGTOOL**, and **LogoGen**.
 - b. If you installed the Logo Generator application to a custom location or gave the application folder a custom name, you will need to select your custom directory path.
 - c. You should now be at a location in the PC directory structure where the browse list box shows the **LOGOGEN.EXE** file.
5. Select the **LOGOGEN.EXE** file (Logogen.exe will be displayed in the file name box), and then click the **OK** button. The directory path to the Logogen.exe file will now be displayed in the Command Line box of the Create Shortcut dialog box.
6. Click the **Next** button in the Create Shortcut dialog box. The default name of the shortcut icon is now displayed in the dialog box. You can edit the icon name to suit your needs or accept the default name.
7. Click the **Finish** button to finish creating the desktop shortcut icon. The Logogen.exe shortcut icon will now appear on the PC desktop. You can start the Logo Generator application by double-clicking the **LOGOGEN.EXE** (or your custom name) shortcut icon.

Starting and Exiting Logo Generator

When you complete the installation procedure, you can use any of the following methods to start the Logo Generator application:

- Double-click the **LOGOGEN.EXE** shortcut icon on the PC desktop that you created during the installation procedure.
- Select **Start > Programs > LOGOGEN**.
- Select **Run** from the **Start** menu, and then enter **logogen** in the text box.

To exit (quit) the Logo Generator application, select **File > Exit**.

Elements of the Logo Generator Window

Figure C-1 shows the Logo Generator application window that appears when you first start the application. Table C-1 provides a description of the elements in the application window.

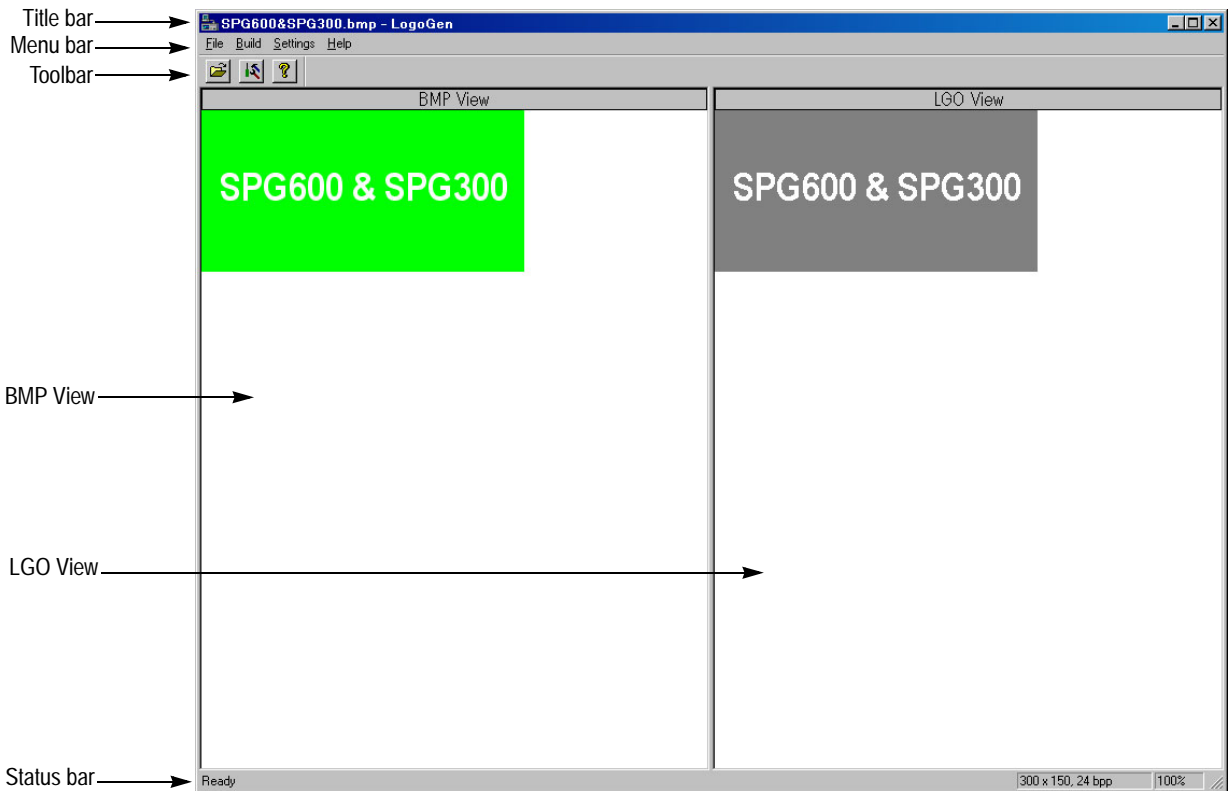





Figure C-1: Logo Generator application window

Table C-1: Elements of the Logo Generator window

Element	Description
Title bar	Displays the name of the application and contains the standard window-sizing boxes for Windows.
Menu bar	Displays the names of the four pull-down menus. Refer to <i>Using the Logo Generator Menus</i> on page C-6 for detailed information about the functions available in the menus.
Toolbar	Provides shortcut buttons for many of the most often used menu commands. Click a toolbar button to select the corresponding command. You can toggle the toolbar display on and off using the Toolbar commands in the Settings pull-down menu. Table C-2 describes the function of each toolbar button.
BMP View	Displays the selected bitmap image.
LGO View	Displays the logo image converted to a gray scale.
Status bar	Displays the bitmap size, bits per pixel, and conversion status (%) of the gray scale image.

Table C-2: Toolbar button description

Icon	Name	Function
	Open	Equivalent to the Open command in the File menu
	Build Logo File	Equivalent to the Build Logo File command in the Build menu.
	About	Equivalent to the About LogoGen command in the Help menu.

Using the Logo Generator Menus

The Menu bar displays the names of the four pull-down menus: File, Build, Settings, and Help. This section describes the function of each selection in these menus.

File Menu The File menu contains commands for managing file operation and for exiting the Logo Generator application. Table C-3 describes each of the File menu commands.

Table C-3: File menu commands

Command	Function
Open	Displays the Open dialog box where you can select the bitmap file you want to convert to a logo file.
Exit	Exits the Logo Generator application.

Build Menu The Build menu contains a command that creates a logo file. Table C-4 describes the Build menu command.

Table C-4: Build menu command

Command	Function
Build Logo File	Creates a logo file (.lgo) from a bitmap file (.bmp).

Settings Menu The Settings menu contains commands for setting the gray level and background color for a logo image. Table C-5 describes each of the Settings menu commands.

Table C-5: Setting menu commands

Command	Function
Gray Level	Sets the gray level when a bitmap image is converted to a logo image. Clicking this command opens the Gray Scale Settings dialog box. Refer to <i>Gray Scale Settings Dialog Box</i> on page C-7 for detailed information about the dialog box parameters.
Miscellaneous	Sets a logo name, user comment, and display position. Clicking this command opens the Miscellaneous Settings dialog box. Refer to <i>Miscellaneous Settings Dialog Box</i> on page C-8 for detailed information about the dialog box parameters.
Background	Sets the background color of the logo image.
Toolbar	Toggles the display of the Toolbar on and off in the application window. A check mark precedes the command in the menu when the Toolbar is selected for display.
Status Bar	Toggles the display of the Status bar on and off in the application window. A check mark precedes the command in the menu when the Status bar is selected for display.
Save Settings	Specifies whether all the settings are saved or not.

Gray Scale Settings Dialog Box. The Gray Scale Settings dialog box (see Figure C-2) appears when you click the **Gray Level** command.

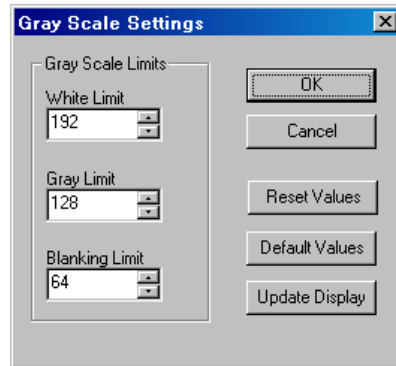

Figure C-2: Gray Scale Settings dialog box

In this dialog box, you can set the following parameters:

- **White Limit:** Sets the maximum level for the Gray 2 level. The gray scale values greater than this value become white level. You can set the value from 0 to 255. The default value is 192.
- **Gray Limit:** Sets the maximum level for the Gray 1 level. The gray scale values greater than this value become white level. You can set the value from 0 to 255. The default value is 128.
- **Blanking Limit:** Sets the maximum level for the Transparent. You can set the value from 0 to 255. The default value is 64.

OK button enables all of the settings in the dialog box and closes the dialog box.

Cancel button cancels all of the settings in the dialog box and closes the dialog box.

Reset Values button resets all of the settings to the values when the dialog box is first displayed.

Default Values button resets all of the settings to their default value.

Update Display button enables all of the settings with the dialog box opened.

Miscellaneous Settings Dialog Box. The Miscellaneous Settings dialog box (see Figure C-3) appears when you click the **Miscellaneous** command.

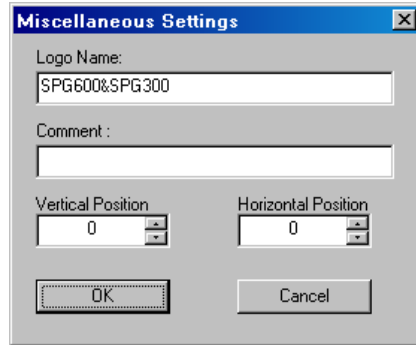

Figure C-3: Miscellaneous Settings dialog box

In this dialog box, you can set the following parameters:

- **Logo Name:** Sets the logo name. This logo name is used when you select a logo from the Logo submenu in the sync pulse generator. The default logo name is the file name.
- **Comment:** Sets the user comment to be described in the logo file. You need not enter any comments in general use.
- **Vertical Position:** Sets the vertical position where the logo is displayed on the monitor. You can set the value from -100% to 0%. The vertical position can also be set from the Logo submenu in the sync pulse generator.
- **Horizontal Position:** Sets the horizontal position where the logo is displayed on the monitor. You can set the value from -100% to 0%. The horizontal position can also be set from the Logo submenu in the sync pulse generator.

OK button enables all of the settings in the dialog box and closes the dialog box.

Cancel button cancels all of the settings in the dialog box and closes the dialog box.

Help Menu

The Help menu contains command that display the version information about the Logo Generator application. Table C-6 describes the Help menu command.

Table C-6: Help menu command

Command	Function
About LogoGen	Displays information including the Logo Generator software version number and copyright information.

Logo Generator Tutorials

This subsection describes the basics of operating the Logo Generator application.

Creating a Logo File Perform the following steps to create a logo file (.lgo) from a bitmap file (.bmp):

1. Select **File > Open** or click the **Open** toolbar button to open the Open dialog box.
2. In the Open dialog box, select the bitmap file that you want to convert to a logo file, and then click the **Open** button. This displays the bitmap image in the BMP View and the logo image converted to a gray scale in the LGO View.
3. Select **Gray Level** from the **Settings** pull-down menu to open the Gray Scale Settings dialog box shown in Figure C-2 on page C-7.
4. In the Gray Scale Settings dialog box, set the gray levels for the logo image.
5. Select **Miscellaneous** from the **Settings** pull-down menu to open the Miscellaneous Settings dialog box shown in Figure C-3 on page C-8.
6. In the Miscellaneous Settings dialog box, set the vertical and horizontal positions for the logo to be displayed on the monitor. You can also set the logo name and user comment in the dialog box.
7. Select **Background** from the **Settings** pull-down menu to change the background color for the logo image.
8. Selects **Build > Build Logo File** or click the **Build Logo File** toolbar button to open the BMP to LGO Conversion dialog box shown in Figure C-4.

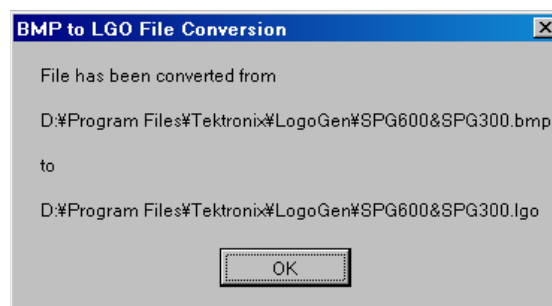

Figure C-4: BMP to LGO File Conversion dialog box

9. Click the **OK** button to create the logo file.

The created logo file can be uploaded to the sync pulse generator using the Remote Interface. Refer to *Appendix B: Using the Remote Interface* for information about uploading a logo file.

Appendix D: Rackmounting the Instrument (SPG600 Option 1R Only)

This section provides instructions for installing the SPG600 into a standard 19-inch equipment rack.

NOTE. For information on how to install the SPG300 into a standard 19-inch equipment rack, refer to the Instructions included in each of the rackmounting kits.

Minimum Tool and Equipment List

The following tools are required to install the rackmounting hardware into the equipment rack. All tools are standard tools that are readily available.

Table D-1: Tools required for rackmount installation

Item no.	Name	Description
1	Screwdriver handle (magnetic)	Accepts 1/4 inch hex-head driver tips
2	No.2 Phillips tip	Phillips-driver tip for M3 size screw heads
3	No.2 Pozidrive tip	Pozidrive-driver tip for number 2 size screw heads



WARNING. To prevent the rackmounted instrument from tipping forward onto the operator, install the instrument so that the operator will be able to access all of its rear-panel connectors without pushing down on the instrument

Verify that the rack does not become unstable with the instrument fully extended. Do not leave the instrument extended when finished accessing the rear panel.

Installation Instructions

This procedure describes how to assemble and install the slide-out tracks in the equipment rack, and then how to install the instrument into the rack.

Assembling the Slide-out Tracks

1. Identify the equipment rack right versus left slide-out track assemblies by finding the date code label on each assembly. The equipment rack left-side assembly has a date code that ends with “LH”, for left hand. The equipment rack right-side assembly has a date code ending with “RH”.
2. Measure the distance between the front and rear rail of the equipment rack.
3. Align the rear bracket to the right slide-out track as shown in Figure D-1. Note that the rear bracket has multiple pairs of mount-through holes. When aligning the bracket and track, be sure to select a pair of holes that mount the rear bracket so that the flange-to flange distance matches the front-rail to rear rail spacing of the rackmount rack just measured in step 2.
4. Using a screwdriver with a number two pozidriv tip, secure the rear bracket to the right slide-out track using two 10-32 screws and a bar nut. Leave the screws loose so that you can adjust the overall length of the slide-out track assembly in the rack.
5. Repeat steps 3 and 4 to assemble the left slide-out track assembly.

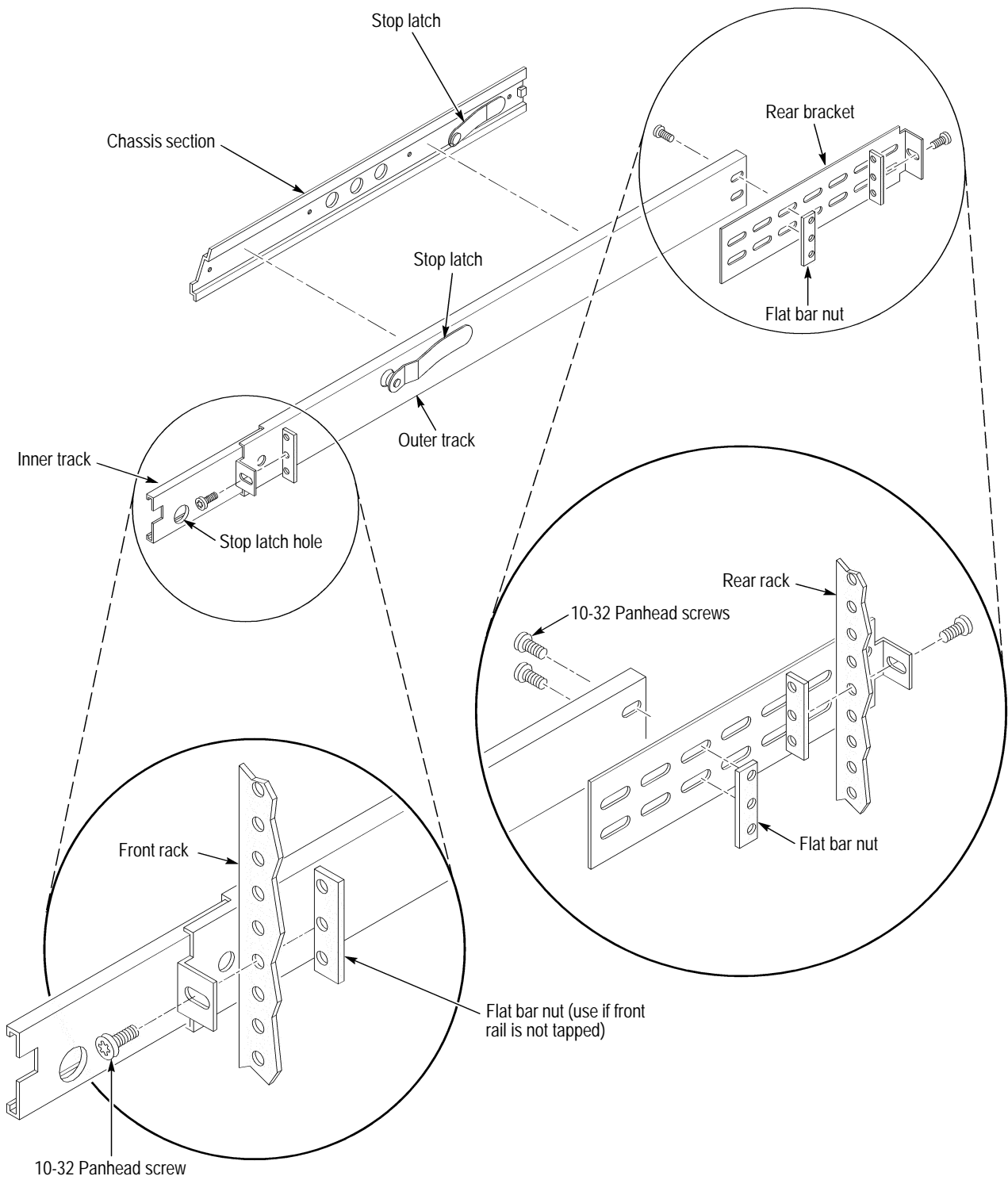

Figure D-1: Assembly of slide-out track assemblies (right slide-out track)

Installing the Instrument

1. Working from the front of the rack, pull the inner track of each slide-out track assembly until it extends out the front of the rack. Continue to pull them out until they lock.
2. Insert the instrument left and right tracks into the ends of the rack tracks just extended. Make sure to insert the instrument tracks inside of the inner rack tracks extended in step 1.
3. Push the instrument into the rack until it stops.
4. Push both stop latches, located on the outside of each track, and continue to slide the instrument all the way into the rack.
5. Tighten the two screws that were left loose at the rear of the rack when you did step 3 in *Mounting the Slide-Out Tracks* on page D-4, and then pull the instrument part way out of the rack.
6. Be sure the two screws that were left loose at the front of the rack are loose enough to allow the slide-out track assemblies to seek the appropriate positions.
7. Retighten the two screws and push the instrument all the way into the rack. If the tracks do not slide smoothly, readjust the rail assemblies using the method just detailed.
8. When adjusting is completed, tighten all rail assembly 10-32 screws using 28 inch-lbs of torque.
9. Using a number two phillips screwdriver, install the 10-32 screw attached to your rack in one of the two mounting holes at the right side of the front panel. Repeat for the second mounting hole. Tighten both screws using 25 inch-lbs of torque.
10. Repeat step 9 to install the two screws in the left side of the front.

Appendix E: User Maintenance

This appendix contains procedures for cleaning and performing preventive maintenance on the sync pulse generator.

Cleaning

General Care Protect the instrument from adverse weather conditions. The instrument is not waterproof.



CAUTION. To avoid damage to the instrument, do not expose it to sprays, liquids, or solvents.

Do not use chemical cleaning agents; they may damage the instrument. Avoid chemicals that contain acetone, benzene, toluene, xylene, or similar solvents, because they may damage the plastic.



WARNING. To avoid personal injury, remove the power cord before cleaning the instrument.

Cleaning the Exterior Remove the power cord before cleaning the instrument. Clean the exterior surfaces of the instrument with a dry, lint-free cloth or a soft-bristle brush. If dirt remains, use a cloth or swab dampened with a 75% ethyl alcohol solution. A swab is useful for cleaning in narrow spaces around the controls and connectors. Do not use abrasive compounds on any part of the instrument.



CAUTION. Do not allow moisture inside the instrument. During exterior cleaning, use only enough solution to dampen the cloth or swab.

Preventive Maintenance

Preventive maintenance mainly consists of periodic cleaning. Periodic cleaning reduces instrument breakdown and increases reliability. Clean the instrument as needed, based on the operating environment. Dirty conditions may require more frequent cleaning than computer-room conditions.

Index

Numerics

1+2/RIGHT, 2-5
100 BASE-T, 2-4
3+4/LEFT, 2-5

A

AES 1+2, 2-5
AES 3+4, 2-5
AES 5+6, 2-5
AES 7+8, 2-5
AES/EBU submenu, 3-19
Alarm status, 3-34
Analog test signals, 3-7
AUDIO button, 2-2
Audio channel submenu, 3-21
Audio menu, 3-17

B

Broadcast address, 3-32

C

Certifications and compliances, A-10
CH1, 2-4
CH2, 2-4
CH3, 2-4
CH4, 2-4
Cleaning, E-1
Configuration submenu, 3-37

D

DHCP, 3-32

E

Embedded parameters submenu, 3-20
Entering an option key, 3-36

F

Factory Default, 3-28
Factory default settings, 3-45
Firmware version, 3-36
FPGA version, 3-36
Front panel disable, 3-27
Front-panel buttons, 2-1

G

Gateway address, 3-32
General characteristics, A-1
GENLOCK button, 2-2
Genlock menu, 3-23
Genlock source, 3-23
Genlock status, 3-23
Genlock timing submenu, 3-25
GPI, 2-4
 Outputting an alarm signal, 3-43
 Pin assignment of the connector, 3-41
 Recalling a preset, 3-42
GPI submenu, 3-34
Gray Scale Settings dialog box, C-7

I

ID text submenu, 3-15
IP address, 3-32

L

LCD contrast, 3-27
LCD display, 2-2
Lock loss action, 3-24
Logo Generator
 installation instructions, C-1
Logo Generator menus
 Build menu, C-6
 File menu, C-6
 Help menu, C-8
 Settings menu, C-6
Logo Generator tutorials, C-9
Logo submenu, 3-14

M

Menu control buttons, 2-2
Miscellaneous Settings dialog box, C-8

N

Network information submenu, 3-30
Network setup submenu, 3-30

O

Optional accessories, 1-12
Options, 1-12
Output configuration, 3-38
Outputting an alarm signal, 3-35
Overlay submenu, 3-13

P

PANEL ENABLE button, 2-2

Power code options, 1-13
Power connector, 2-4
Power On Default, 3-28
Preset
 recalling, 3-29
 saving, 3-29
Preset submenu, 3-28
Preventive maintenance, E-1
Product description, 1-1

R

Rackmounting, D-1
Rear-panel connectors, 2-3
Recalling a preset, 3-29
REF, 2-4
Reference indicators, 2-3
Related manuals, ix
Remote interface, B-1
Renaming a preset, 3-29

S

Saving a preset, 3-29
SDI 1, 2-4
SDI 2, 2-4
SDI parameters submenu, 3-16
SDI test signals, 3-10
Serial number, 3-36
Service options, 1-12
Service support, contact information, x
Specifications, A-1
Standard accessories, 1-10
Subnet mask, 3-32
SYSTEM button, 2-2
System information
 firmware version, 3-36

FPGA version, 3-36
option key, 3-36
serial number, 3-36
System information submenu, 3-35
System menu, 3-26
System setup submenu, 3-36

T

Test signal (analog) submenu, 3-6
Test signal (SDI) submenu, 3-9
Timing (analog) submenu, 3-11
Timing (SDI) submenu, 3-12

U

User Default, 3-28
Using a Web browser, B-1
Using Logo Generator, C-1
Using the Java applet, B-3

V

VIDEO button, 2-2
Video menu, 3-2

W

WORD CLK, 2-5