



"Telecommunication Products to solve Telecommunication Problems"

## CK-2 Promotion-On-Hold Module (For GE 29487GE2 and 29488GE2)

### Introduction

Thank you for purchasing the Skutch CK-2 Promotion-On-Hold Module for the GE 29487 and 29488 four line telephones. The CK-2 supplies Promotion-On-Hold whenever any call is placed ON HOLD with the telephone's hold button. The CK-2 not only supplies Promotion-On-Hold, but it also removes the annoying "BEEPS" that these telephones produce every 3

seconds when the phone is placed on hold. The CK-2 will supply Promotion-On-Hold to callers that are placed ON HOLD ONLY from the GE 2-9487 or 2-9488 telephones. Other makes and/or models of telephones can be used with the CK-2 but they will not produce Promotion-On-Hold when placed ON HOLD.



### Installation

There are two methods that can be used to install the CK-2 module. It basically depends on how close the telephones are together. If all of the telephones are within 25 feet of a central point, then method #1 can be used. In this case modular cords MUST be run directly from the CK-2 box to each of the telephones. If your telephones are spread out more than 25 feet apart, then you will need to use method #2. In this case you will have to have a qualified person install four telephone jacks in front of your all of your telephones. The CK-2 will have to be connected to these jacks. In this case the wiring to the telephones remain unchanged. See method #2 for more details.

## Method #1

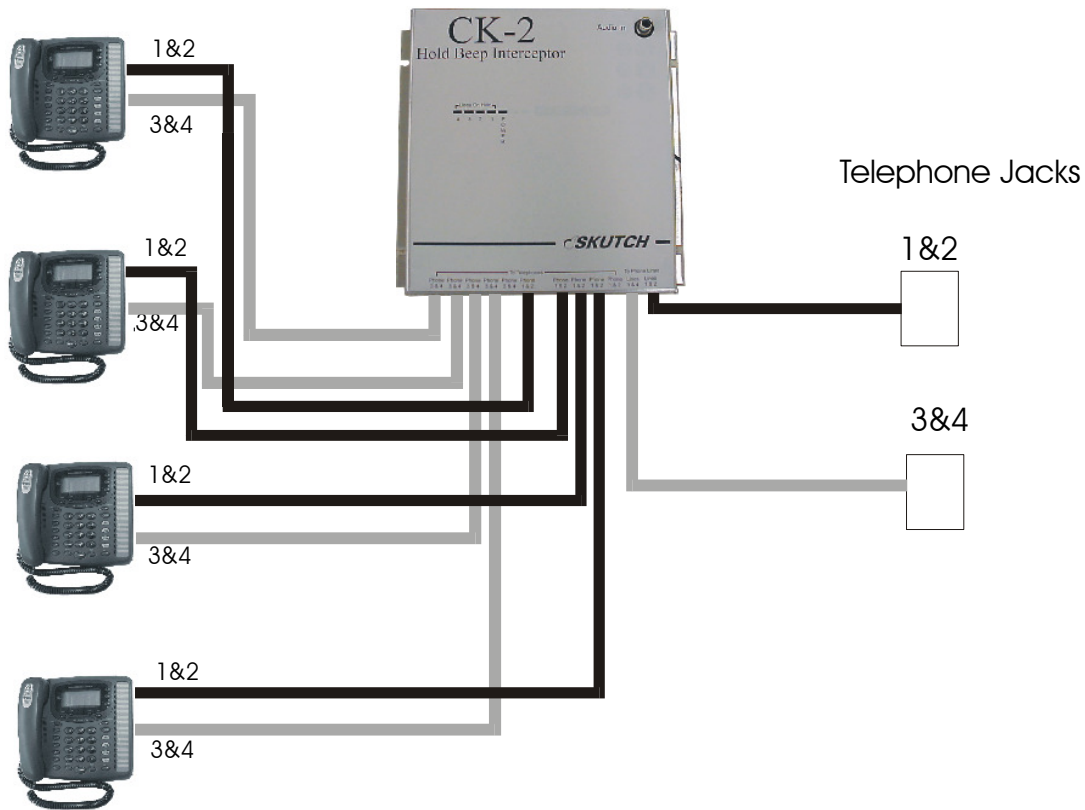

### Method #1 Installation:

This method should only be used when all phones are within close proximity of each other. Up to five telephones can be connected with this method. It is okay to use telephone extension cables if needed.

1- Disconnect all of your telephones.

2- Using a supplied telephone cord, connect one end to a wall telephone jack, Lines 1&2. Connect the other end of the cord to the CK-2- "To Phone Lines", "Lines 1&2".

3- Using a supplied telephone cord, connect one end to a wall telephone jack, Lines 3&4. Connect the other end of the cord to the CK-2- "To Phone Lines", "Lines 3&4".

4- Connect a telephone cord from each line 1&2 jack on each telephone, to a CK-2 jack that is labeled "Phone 1&2". Order does not matter.

5- Connect a telephone cord from each line 3&4 jack on each telephone, a CK-2 jack that is labeled "Phone 3 & 4". Order does not matter.

6- Connect a audio cable from your audio source to the Audio In jack on the CK-2. Use the audio cable supplied with the CK-2 ONLY if your audio source is a CD player. If you are using a digital player, the digital player should have come with the needed audio cable.

7- Connect the CK-2 and all telephone's power cubes to power.

## Method #2 Installation:

This method should be used when your phones are spread out over a wide area It requires that 4 telephone jacks be installed by a qualified person, in-between ALL PHONES, and the telephone company. The DEMARCATION POINT is one place that these jacks could be installed. The following diagram shows the relative location of these jacks:

The following is a wiring diagram of how the jacks are to be installed:

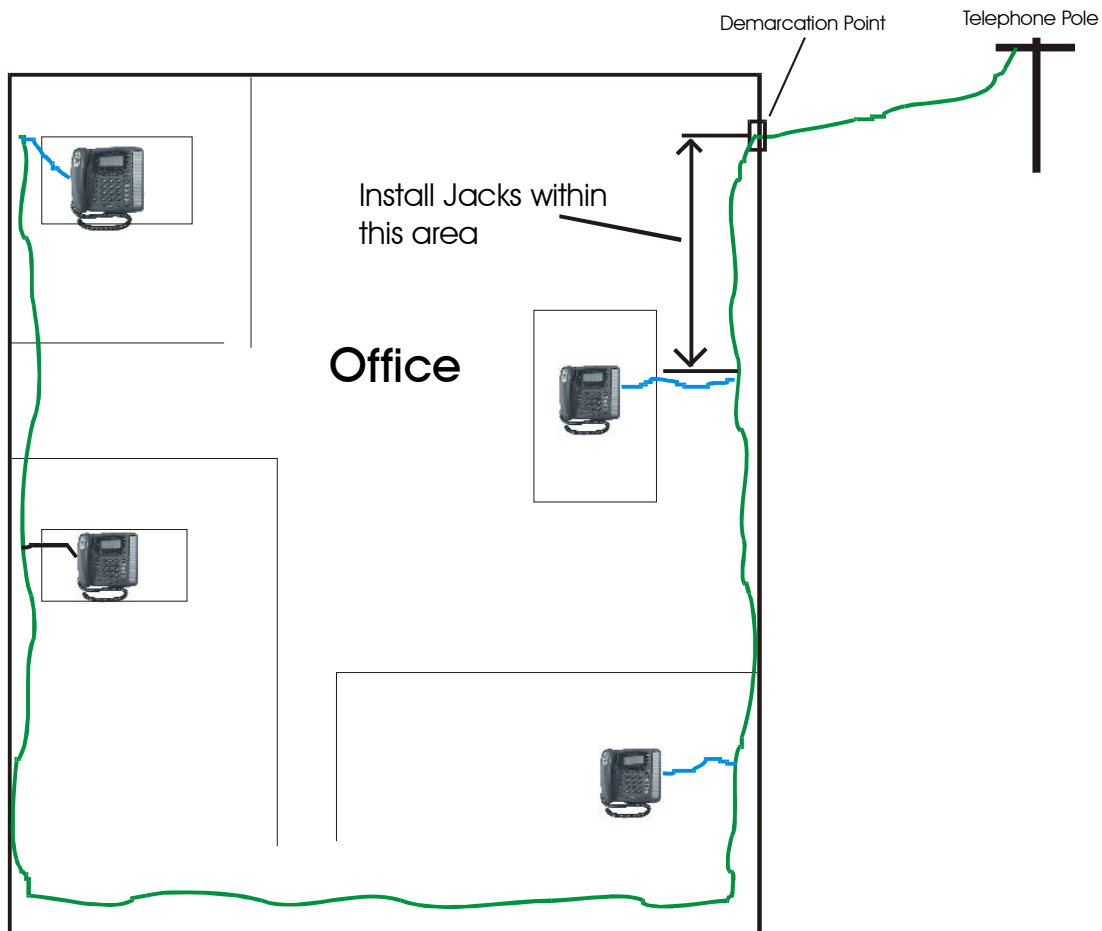

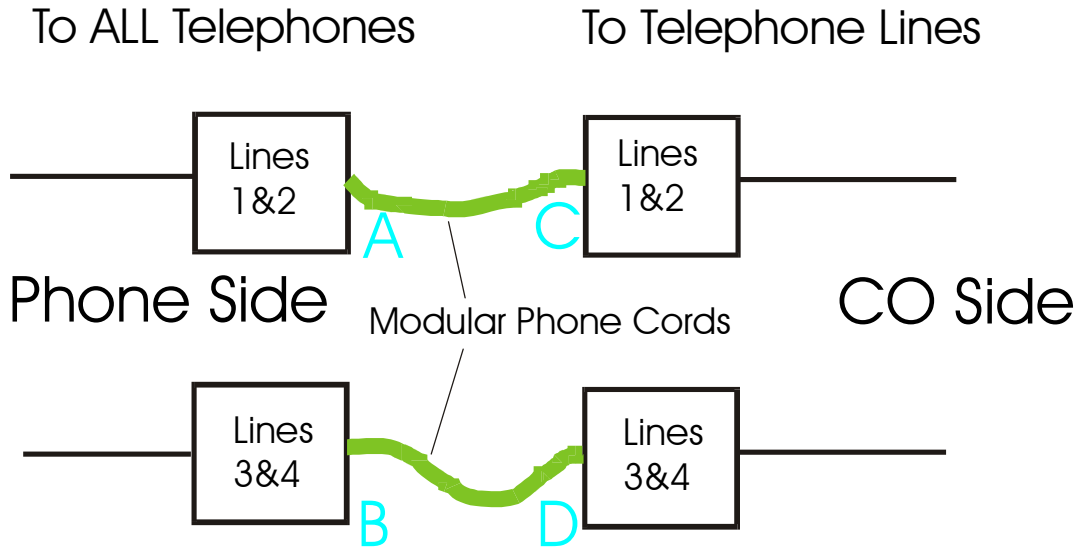

Red = Line #1 Ring  
 Green = Line #1 Tip  
 Black = Line #2 Ring  
 Yellow = Line #2 Tip

**GREEN CORDS** are for Testing ONLY!  
 They are removed before installing the CK-2.

- 1- When the jacks have been installed, without the modular cables attached as shown above by the GREEN lines, all lines, on all phones should be dead. Check this before continuing. If any of the phones get dial tone, the wiring is wrong. Fix this before continuing.
- 2- Now attach the two modular cords (shown in GREEN), between the jacks, as shown above. All lines should be working on all phones. If any lines are not working, the wiring is wrong. Fix this before continuing!
- 3- Remove the two modular cords that are shown in GREEN.
4. Connect Jack **A** to any one of the five CK-2 jacks labeled "Phone 1 & 2".
5. Connect Jack **B** to "any one of the five CK-2 jacks labeled "Phone 3 & 4".
6. Connect Jack **C** to "To Phone Lines" "Lines 1 & 2"
7. Connect Jack **D** to "To Phone Lines" "Lines 3 & 4"
- 8- Connect the audio cable from your audio source to the "Audio In" jack on the CK-2. If the audio source is a CD player, use the supplied audio cable with the CK-2. If your source is a digital player, use the audio cable that came with it.
- 9- Connect Power Cube from CK-2 to power.

## **Operation:**

Operation is simple. When you place a caller ON HOLD from any of the GE 29487GE2 or 29488GE2 phones, the corresponding "Lines On Hold" light on the CK-2 will light and the Promotion-On-Hold audio will be supplied to the ON HOLD caller. When the line is re-answered, the Promotional audio will turn OFF and the call is re-connected to the phone.

**NOTE:** When answering an ON HOLD call, the user must speak into the phone to reset the CK-2. A "Hello" response is more than adequate.

## **• ONE YEAR LIMITED WARRANTY**

This SKUTCH PRODUCT is warranted against defects for a period of one (1) year from the date of the original invoice. Within this period, we will repair it without charge for parts and labor. To obtain warranty service the product must be returned, at the customer's expense, to SKUTCH Electronics along with a copy of the original invoice. After the unit has been repaired, SKUTCH will ship the PRODUCT back via UPS GROUND service at our expense. If any other form of return shipment is requested, the customer will pay for 100% of the shipping cost.

This Warranty does not apply if in the sole opinion of SKUTCH Electronics, the PRODUCT has been damaged by lightning or any other Acts of God, or by accident, misuse, neglect, or improper packing, shipping, modification or servicing by other than an authorized SKUTCH Service Center.

EXCEPT AS SPECIFICALLY PROVIDED IN THIS AGREEMENT, THERE ARE NO OTHER WARRANTIES, EXPRESSED OR IMPLIED, INCLUDING, BUT NOT LIMITED TO, ANY IMPLIED WARRANTIES OR MERCHANTABILITY OR FITNESS FOR A PARTICULAR PURPOSE AND IN NO EVENT SHALL SKUTCH ELECTRONICS BE LIABLE FOR LOSS OF PROFITS OR BENEFITS, INDIRECT, SPECIAL, CONSEQUENTIAL OR OTHER SIMILAR DAMAGES ARISING OUT OF ANY BREACH OF THIS WARRANTY OR OTHERWISE.