



HD-SD VariTime™ Sync Generator PT5300



Solutions in Audio & Video

- Multi-format sync capability: 19 HD formats in addition to PAL, NTSC and standard definition SDI systems
- Master application with internal or external high stability reference
- VariTime™ subnanosecond delay compensation
- Full genlock capability: 1 frame for HD; 2 fields for SDI; 4 and 8 fields for NTSC and PAL
- 4 individually timed HD and SD serial digital outputs
- Up to 8 individually timed tri-level sync outputs
- Backwards compatibility with modules for PT5230 and PT5210
- Analogue outputs in combination with SDI outputs
- Embedded audio in HD and SD serial digital outputs.
- Dual AES3 digital audio generator. Separate Word-clock output.
- "Lip Sync" moving element in SDI test patterns synchronized to embedded audio "click"
- Philips Circle pattern or FuBK test pattern
- Programmable text strings in test pattern generators can be placed on the screen where needed
- Time and date option for test pattern generators

In today's environment, sync requirements are becoming increasingly diverse, as they need to support multiple production formats. A new flexibility is called for in synchronising systems.

The next generation VariTime™ sync generator shares the same potential feature set as earlier VariTime™ sync generators. Additionally it supports 19 HD formats of tri-level sync and SDI signals in HD with 1,485 Mbit and in SD with 270 Mbit.

The PT5300 HD-SD VariTime™ Sync Generator is specially designed to fit into this new environment with all signals needed for synchronisation, fault finding and checking of the entire video chain. The generator conforms to the relevant ITU, SMPTE, EBU and AES standards.

PT5300 Base Units

Two base units are available for the PT5300 series:

- The PT5300HD is a combined HD and SD sync generator providing both tri-level as well as NTSC and PAL black burst signals.
- The PT5300SD generates SD sync signals in PAL and NTSC, but may be extended to HD by adding the PT8611 quad tri-level sync board.

In master sync applications both base units may be controlled by the internal, high precision internal XTAL oscillator, or by a 10 MHz signal coming from a GPS receiver. In slave applications PT5300 can be genlocked to PAL and NTSC video or black burst signals.

All HD and SD outputs are individually timeable for synchronisation of sophisticated video installations.

Flexibility - Modular and Multistandard

Several generators can be added to the base unit making multiple HD and SD serial digital outputs available and also analogue PAL or NTSC at the same time. The configuration may also include several tri-level or additional black burst outputs.

This makes the generator perfect for use in a mixed SD and HD environment.

The modular approach enables multi-format configuration:

- 19 HD formats for tri-level sync outputs.
 - HD-SDI outputs selectable for HD formats in 720p, 1080i, and 1080p formats
 - SD-SDI, 625-lines and 525-lines, and analogue composite PAL and NTSC.
- AES3 Audio Generators, a Digital Genlock input and a Time Clock input can also be added all in the same instrument.

Tri-Level Sync Generator

The generator has 4 separately controllable tri-level outputs. For each output any of 19 HD formats can be independently selected. For several HD formats genlocking to the frame rates of SD 525-line and 625-line systems will automatically take place. In this way frame synchronisation is ensured between SD and HD. Each of the 4 tri-level outputs can be individually delayed or advanced with 6.7 ns resolution in phase to each other and the mainframe system sync or genlock input.

HD-SD Test Signal Generator

On any of its 4 independent HD and SD serial outputs the generator can supply test signals in 1080p, 1080i, 720p, and SD formats. The test signals include several colour bar signals, colour black, SDI checkfield, monitor alignment signals, and test pattern for "lip-sync" check.



Combination test pattern with clap tree for lip-sync check.

All signals have embedded audio with test tones. A programmable text may be superimposed on the colour bar signals for identification.

SD-SDI Test Signal and Pattern Generators

The SD serial digital generators work both in 625 and 525 line formats, and there are also various versions to choose from:

- A basic Test Signal Generator contains less complex test signals, i.e., colour-bars, PLUGE, crosshatch, window, etc.
- An extended Test Pattern Generator has a broad range of test signals plus one complex test pattern: "Philips" Circle Pattern in 625 line, 4:3 format.
- A high-end Test Pattern Generator contains a very wide range of test signals, like the "Philips" Circle pattern and FuBK test pattern in both 4:3 and 16:9 aspect ratios as well as other complex test patterns.

Digital audio signals are embedded in all SDI outputs.

Analogue Test Signal Generator

The analogue output module is a dual standard module (PAL or NTSC), which provides test signals and complex test patterns as the "Philips" Circle Pattern and the FuBK pattern for the analogue domain.

Genlock and Timing Adjustment

The PT5300 is genlockable to a traditional black burst signal, but can also be locked onto continuous wave signals such as subcarrier, 5 MHz, and 10 MHz reference frequencies. It can even lock to a 525-lines video signal and still generate PAL and 625-line SDI signals.

Next to the common genlock phase adjustment for the entire basic instrument, each generator is also independently timeable (infinite timing over 2 fields for SDI and 4 or 8 fields for respectively NTSC and PAL)

"Lip Sync" Moving Element in Pattern

To reveal that a serial digital video transmission is "live" and not in a "freeze" condition, a moving element can be selected for some of the complex SDI test patterns. The movement is synchronised with a "click" in the embedded audio signal.

Text and clock

Three lines of text can be superimposed onto the video signals. In the complex test patterns the position of the text is optimized for the black text fields.

Clock (date and time) can also be inserted. Date and clock are either controlled by LTC, VITC or from the internal reference.

AES3 Digital Audio Generators

The digital audio generators supply digital silence and a selection of reference

test tones. The unit contains two independent audio generators and separate word-clock outputs. Some of the audio test signals include audible markers that make it possible to identify right and left channels by using a loudspeaker.

Ease of Operation

The main sync generator functions are controlled via separate pushbuttons. A "Compass Key" together with an LCD display guide the user through the menu selections with help of intuitive icons.

Presets

Six complete instrument presets are stored in a non-volatile memory. This makes it simple to change the configuration of the outputs for different applications.

Changeover Control

The PT5300 is the "New Generation" of the Varitime™ Sync Pulse Generator and they work together in an automatic change over set-up.

Built-in fault detection circuitry determines when to send an error flag to the PT5211 Varitime™ Changeover unit.

Remote Control

The RS-232 remote control interface provides full control over all functions of the generator. Parameters for each output may be adjusted remotely and a complete set-up can be copied from one instrument to another. Instead of the RS-232 control, an internal configuration easily switches the interface to a simple ground closure control, which features a selection of presets and a few basic functions.

HD-SD Formats

Table 1 HD and SD-SDI Formats supported by PT5300HD

Format ¹⁾	Tri-Level Sync	PT8612 TSG	Genlock to BB	
1080p/60	x			HD 1080p
1080p/59.94	x			
1080p/50	x			
1080p/30	x	x		
1080p/29.97	x	x	x	
1080p/25	x	x	x	
1080p/24	x	x		
1080p/23.98	x	x		HD 1080i
1080i/30	x	x		
1080i/29.97	x	x	x	
1080i/25	x	x	x	HD 720p
720p/60	x	x		
720p/59.94	x	x	x	
720p/50	x	x	x	
720p/30	x	x		
720p/29.97	x	x	x	
720p/25	x	x	x	
720p/24	x	x		SD
720p/23.98	x	x		
576i/25 (625)		x	x	
487i/29.97 (525)		x	x	

¹⁾ Format: "Number of active lines" "i(nterlaced) or p(rogressive)" / "Frame rate". For interlaced formats frame rate is equal to half of field rate.

Fail-Safe Sync Generator System

The fail-safe operation of the sync generator system is demanded wherever the interruption of the synchronizing signals and thereby the breakdown of a video production or a TV transmission could cause major losses.

With a dual and independent sync generator system coupled to an automatic change-over unit from DK-Technologies the uninterrupted operation of the sync system is secured. A typical, fail-safe system is shown in the drawing. The system will work either as a Master Sync System or as a Slave System genlocked to a master.

The high flexibility of the PT5300 allows the configuration to meet specific requirements through the addition of optional modules. Up to 12 tri-level sync outputs, 8 black burst outputs, multiple HD and SD-SDI test signal outputs, as well as analogue PAL and NTSC test signals can be added. All video signals can be timed individually and precisely over the full video frame. Audio signals are embedded in all SDI signals. A dual, separate AES digital audio generator can be added supplying audio tones, silence signal, and wordclock locked to video.

Signals from the sync generators are applied to the PT5211 Change-Over Unit. Through relays either the main or reserve sync generator signals are

switched through to the outputs of the PT5211.

In each PT5300 the amplitude at the outputs are monitored as well as the internal supply voltages. By any malfunction in the main sync generator, a control signal switches the PT5211 to the reserve generator.

By placing the detectors in the sync generators, the change-over unit is kept

the simplest possible to obtain a very high reliability. The MTBF of the total system is mainly determined by the PT5211, and is thus maximized.

The PT5211 base unit can switch up to 4 video and audio signals in 75 ohm BNC interfaced signals. Fully equipped with optional relay modules it can switch up to 12 BNC channels or up to 8 BNC channels and 2 XLR balanced channels.

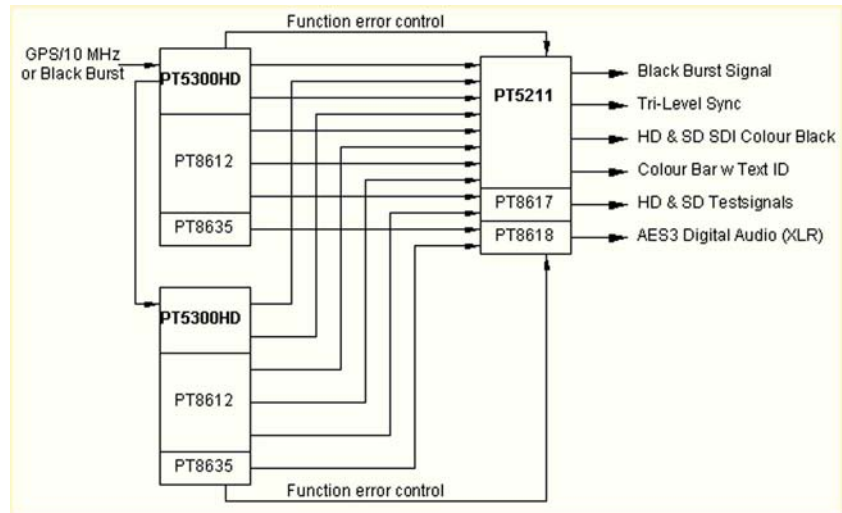

Dual PT5300 sync generator system with PT5211 automatic change-over unit secures uninterrupted supply of synchronizing signals for video and audio.

Related Products

PT5202 Compact VariTime™ Sync Generator



PT5202 is a cost effective stand-alone solution with an internal 10MHz TCXO master reference, genlockable, with a user-friendly front panel control and key features such as:

- ▶ Dual standard 625/50 PAL and 525/60 NTSC operations
- ▶ Genlock to PAL and NTSC
- ▶ 3 independent BB outputs, individually timeable
- ▶ 1 SD-SDI output, 625/50 and 525/60 with embedded audio incl. SD-SDI colour black
- ▶ Source identification as text element with up to 16 characters
- ▶ 1 analogue video output PAL or NTSC
- ▶ 1 AES3 or analogue stereo output
- ▶ 1 Wordclock at 44.1 or 48 kHz
- ▶ 4 programmable presets directly selectable
- ▶ Operation also via RS-232 interface.

PT5210 VariTime™ Digital Sync Generator



PT5210 is a high end SPG fulfilling the highest requirements to stability and reliability. In master applications it can be controlled by the internal oven controlled X-tal oscillator or it can be locked to an external reference, such as GPS or DCF77. The unit is flexible in construction to meet the exact requirement for the application.

- ▶ VariTime™ 8 fields for PAL
- ▶ VariTime™ 4 fields for NTSC
- ▶ VariTime™ sub-nanosecond delay compensation on all BB outputs
- ▶ Genlock to SD-SDI, PAL, NTSC or 10MHz signals
- ▶ Multi-standard 625/50, 525/60 and dual standard operations
- ▶ Exceeds the ITU, SMPTE and the EBU requirements
- ▶ Up to 8 BB outputs individually timeable.

PT5211 VariTime™ Change-Over Unit



PT5211, is an extremely flexible Change-Over unit capable of switching all kinds of video, audio, and sync signals, and it is designed to meet the requirements for extremely high reliability offering a MTBF as high as 80.000 hrs.

- ▶ Switching analogue video, serial digital video, and digital audio (balanced and unbalanced) signals
- ▶ Basic version offering four channels expandable up to 12 channels (BNC)
- ▶ All unbalanced channels may be used for all types of signals
- ▶ Up to two XLR channels possible
- ▶ Free choice of generator as primary and back-up
- ▶ Configuration compatible with PT5210 and PT5300 series
- ▶ Continues operation with selected SPG in case of power failure on the Change Over unit.

Configuration

The PT5300 series may be configured to a wide variety of applications. The construction is based on 2 base units:

- **PT5300HD** for HD and SD applications
- **PT5300SD** for SD applications

The PT5300SD may at later stage be extended to HD by adding optional modules. The optional modules are of the plug-and-play type and may be installed in the base unit by a skilled technician.

Using the Configuration Matrix

In the matrix below the inputs and outputs are listed horizontally on the rear plate. The numbers refer to the drawing under the matrix. In the upper part of the matrix the input and output positions occupied by the base units are shown.

In the lower part of the matrix the optional modules are listed. The green areas show the primary positions of the inputs and outputs for each module.

Some modules may occupy alternate positions shown by the yellow areas.

To check the legal configuration of a particular instrument any connector should only be occupied by one module. Or in other words, only one position should be used in each input / output column in the matrix.

A few combinations cannot be visualized in this matrix and our support department will always assist in configuring the PT5300.

PT5300 Configuration Matrix		Inputs / Outputs																										
		OUT	IN	WC	AES2	TPG2	TPG2			TPG1	TPG1	A	B	MON	BB1	BB2		SDI1	SDI2	SDI3	SDI4	TL51	TL52	TL53	TL54	AES1	AES1	AES2
		1	2	3	4	5	6	7	8	9	10	11	12	13	14	15	16	17	18	19	20	21	22	23	24	25	26	27
Base Units	PT5300 HD and SD Base Genlock A/B In/Out																											
	PT5300 HD and SD Base Genlock Monitor Output																											
	PT5300 HD and SD Base Dual Black Burst Outputs																											
	PT5300 HD Base Quad Tri-Level Sync Out																											
Optional Modules	PT8604 6 Parallel Sync Outputs																											
	PT8606 SDI Genlock In/Out																											
	PT8608 Dual Black Burst Outputs																											
	PT8609 SDI Black & Colour Bar Out																											
	PT8611 Quad Tri-Level Sync Out																											
	PT8612 Quad HD-SD Test Signal Gen																											
	PT8631 PAL/NTSC Test Signal Gen.																											
	PT8632 SD-SDI Test Signal Gen.																											
	PT8633 SD-SDI Test Signal Gen.																											
	PT8635 Dual AES3 Audio Gen.																											
	PT8637 Time & Clock Interface																											
	PT8639 SD-SDI Test Signal Gen.																											

Primary position

Additional / alternate position

Note:

When PT8637 is mounted, only the BNC output is available from one of the two audio generators in PT8635.

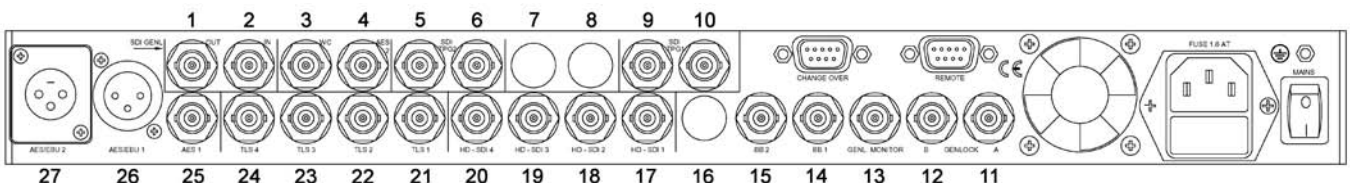

Table 1—Signal Survey—Standard Definition Signals

Signals	SDI Basic	SDI TPG PT		Analog TPG
	PT8639	8632	8633	PT8631
C.BAR				
SMPT E	M	M	M	M
EBU/FCC colourbar	X	X	X	X
75% colourbar, ITU801	X	X	X	
100% colourbar	X	X	X	G
75% bar with Grey		G	G	G
75% bar with red	G	G	G	G
Red, 75%	X	X	X	X
M.BURST				
Multiburst in Y,C _R ,C _B	X	X	X	
Luminance Sweep			X	X
Y, C _R , C _B sweep			X	
Multipulse		X	X	X
Sinx/x			X	X
CCIR 18			G	G
NTC-7 Combination				M
FCC Multiburst				M
WINDOW/FLAT				
10% window	X	X	X	X
15% window	X	X	X	X
20% window	X	X	X	X
100% window	X	X	X	X
Line square wave 15%/100%	X	X	X	X
50% Flat field				X
Flat 100%			X	X
Black/Black Burst	X	X	X	X
SPECIAL				
Check field ITU-801 # 16	X	X	X	
Timing test		X	X	
Field Delay Test		X	X	
Bow Tie		X	X	
Digital analogue Blanking markers		X	X	
Digital grey ITU-801 #1	X	X	X	
Field square wave		X	X	X
Alternating bl/wh 0.1 Hz ITU-801 # 2			X	X
End-of-line pulses ITU-801 # 3			X	
White, end-of-line porches ITU-801 # 10			X	
Blue, end-of-line porches ITU-801 # 11			X	
Red, end-of-line porches ITU-801 # 12			X	
Yellow, end-of-line porches ITU-801 # 13			X	
Cyan, end-of-line porches ITU-801 # 14			X	
LINEARITY				
Shallow ramp		X	X	
Luminance Ramp		X	X	X
Limit Ramp ITU-801 # 4		X	X	
Valid ramp		X	X	
Modulated ramp				X
5-step Staircase	X	X	X	X
Modulated stairs, 5-step		X	X	X
10-step Staircase			X	X
Pulse & bar; 2T, 20T, Bar w. inv 2T			G	G
2T, 12.5T, Bar w. inv. 2T			M	M
CCIR 17			G	G
CCIR 330			G	G
CUR 331			G	G
FCC Composite				M
NTC-7 Composite				M

Signals	SDI Basic	SDI TPG PT		Analog TPG
	PT8639	8632	8633	PT8631
Yellow /Grey ramp ITU-801 #5			X	
Grey/blue ramp ITU-801 #6			X	
Cyan/grey ramp ITU-801 #7			X	
Grey/red ramp ITU-801 #8			X	
C _B , Y, C _R , Y Ramp ITU-801 #9			X	
PATTERN				
Philips Circle Pattern 4:3		G Note 1	X	X
Philips Circle Pattern 16:9			X	X
FuBK 4:3		G Note 1	G	G
FuBK 16:9			G	G
Cross Hatch 4:3	X	X	X	X
Cross Hatch 16:9				X
Circle 4:3				G
Circle 16:9				G
PLUGE	X	X	X	X
Safe area			X	X
250kHz				X
VMT 01			G	G
Embedded Audio				
Audio Group(s)				
Fixed Group 1: CH 1-4	X	X		
Selectable groups: 1, 2, 3 or 4			X	
In all groups, the second stereo pair has continuous tones without click.				
Audio signals:				
Off	X	X	X	
Stereo: 800Hz		X	X	
Stereo: 1kHz	X	X	X	
Stereo: EBU 1kHz		X	X	
Stereo: BBC 1kHz		X	X	
Mono: EBU 1kHz		X	X	
Mono: 1 kHz		X	X	
Dual: 1 kHz + 400Hz		X	X	
Audio levels:				
Silence, 0, -9, -15, -18 dB	X	X	X	
-12, -16, -20 dB		X	X	
Text & Clock				
Text Insertion		X	X	X
Clock and date with option PT8637		X	X	X
Special Functions				
Moving Bar		X		
Lip Sync, clap tree				
Lip Sync, moving bar synchronised to click in embedded audio			G	

X: Dual standard 625/525 lines or PAL/NTSC
 G: 625-line or PAL only
 M: 525-line or NTSC only

Note 1: Only one of either test patterns is available:
 PT8632: "Philips" Pattern
 PT8632/10: FuBK Pattern

Base Unit

PT5300 conforms to the relevant ITU, SMPTE, EBU, and AES standards.

Master Frequency Reference

- 27 MHz internal master frequency: better than 0.25 ppm (0-50 °C)
- Ageing: <1 ppm/year

Analogue Genlock

- Inputs: 75 Ohm looped through input, or two switchable inputs terminated with 75 Ohm (menu configurable)
- Input signal: NTSC or PAL black burst, or continuous wave reference signal.
- Return Loss: >36 dB to 6 MHz
- Genlock Signal: M-NTSC or G-PAL
- Amplitude Nominal: ± 3 dB
- S/N Ratio required: > 26 dB
- Sc-H Phase Nominal: $\pm 45^\circ$
- Pull-in Range: $f_{sc} \pm 20$ Hz
- Burst Lock Jitter: < 0.5°
- Sync Lock Jitter: < 2 ns
- Timing range: ± 4 field (PAL)
 ± 2 field (NTSC)
- Timing resolution: 0.5° of subcarrier
- Continuous Freq. Reference:
 - Subcarrier, 5 MHz, and 10 MHz
 - Amplitude: 1 V ± 3 dB

Analogue Genlock Transparent Channel

The analogue genlock signal is transferred directly to a transparent output.

- Output Impedance: 75 Ohm
- Return Loss: >36 dB to 6 MHz

HD Tri-Level Sync Output

PT5300HD only

- Number of outputs: 4 with independent timing and formats.
- HD formats: 720p, 1080i, 1080p. Frame rates are listed in table 2.
- Connectors: BNC
- Output impedance: 75 Ohm ± 1 %
- Return loss: >30 dB, up to 30 MHz
- Amplitude: 600 mV_{pp} ± 2 %
- Jitter: <0.5 ns.

Analogue Black Burst Output

- Number of outputs: 2 with independent timing and formats.
- Connector: BNC
- Output impedance: 75 Ohm ± 0.5 Ohm
- Return Loss: >36 dB to 5 MHz
- Sync amplitude: 300 mV ± 2 % (PAL) or 286 mV ± 2 % (NTSC)
- Timing range: ± 4 fields (PAL)
 ± 2 fields (NTSC)
- Timing resolution: 0.5° of subcarrier
- Sc-H phase: Default 0°, adjustment $\pm 180^\circ$, resolution <1°
- S/N Ratio: better than 60 dB unweighted to 5 MHz
- Jitter: $\leq \pm 0.5$ ns

Remote Control

The remote interface is configurable, RS-232 or GPI.

RS-232 serial interface:

- SCPI compliant protocol (1995 0)
- Baud rate: 300 to 9600
- Data bits: 7 or 8
- Parity: None, Odd, or Even
- Handshake: XON/XOFF or RTS/CTS

GPI interface:

The parallel remote interface enables selection among 6 presets and the genlock function via TTL compatible ground closure.

Interface connector: 9 pole female D-Sub, internally configured to serial RS232C or parallel ground closure.

HD Tri-Level Sync

PT8611 Quad HD Tri-Level Sync Generator

- Number of outputs: 4 with independent timing and formats.
- HD formats: 720p, 1080i, 1080p. Frame rates are listed in table 1.
- Connectors: BNC
- Output impedance: 75 Ohm ± 1 %
- Return loss: >30 dB, up to 30 MHz
- Amplitude: 600 mV_{pp} ± 2 %
- Jitter: <0.5 ns

PAL/NTSC Black Burst

PT8608 Dual Black Burst Generator

- Number of outputs: 2 with independent timing and formats.
- Connector: BNC
- Output impedance: 75 Ohm ± 0.5 Ohm
- Return Loss: >36 dB to 5 MHz
- Sync amplitude: 300 mV ± 2 % (PAL) or 286mV ± 2 % (NTSC)
- Timing range: ± 4 fields (PAL)
 ± 2 fields (NTSC)
- Timing resolution: 0.5° of subcarrier
- Sc-H phase: Default 0°, adjustment $\pm 180^\circ$, resolution <1°
- S/N Ratio: better than 60 dB unweighted to 5 MHz
- Jitter: $\leq \pm 0.5$ ns

SD-SDI Black / Colour Bar

PT8609 SDI Black/Colour Bar Generator

Each generator has two outputs.

- Signals: SDI black, SMPTE colour bar (525-lines), and EBU 75% and 100% colour bars (625-lines)
- Format: 270 Mb/s component, complies with ITU-R BT 656 and SMPTE 259M.
- Data format: Scrambled NRZI 270 Mbit/sec
- Connectors: 2 BNC
- Output impedance: 75 Ohm
- Return loss: >15 dB, 5 to 270 MHz
- Amplitude: 800 mV ± 10 %
- Jitter: <0.2UI
- Timing range: ± 1 field
- Resolution: 37.5 ns (one half clock cycle of the 13.5 MHz clock)
- Embedded audio: silence on/off
- Auxiliary data:
 - EDH on/off
 - Auxiliary data on/off

Digital Genlock

PT8606 SDI Digital Genlock

SD-SDI digital genlock module with active loop-through.

- Connector: BNC
- Input/output impedance: 75 Ohm
- Format: 270 Mb/s component.
- Complies with SMPTE 259M and ITU-R BT.656

HD-SD Test Signal

PT8612 Quad HD-SD serial digital generator

Four generators individually configurable with HD and SD signals.

- Signals:
 - Video: EBU CB, 75% CB, 100% CB, checkfield, PLUGE, window signals, luminance ramp, combination pattern with lip sync.
 - Text: moving with up to 3 lines of 16 characters inserted in test signals.
 - Audio: Testtones imbedded in the SDI signals.
- HD formats: 720p, 1080i, 1080p. Frame rates are listed in table 1.
- SD formats: 525 lines and 625 lines
- Connectors: BNC, 75 Ohm
- Output resistance: 75 Ohm ± 1 %
- Return loss: >15 dB, up to 1.5 GHz
- Amplitude: 800 mV ± 10 %
- Timing Range: ± 1 field
- Timing resolution:
 - HD: 6,7 ns (one clock cycle)
 - SD: 37.5 ns

SDI Test Pattern, high end

PT8633 SDI Test Pattern Generator, high end

This generator features even more test signals than the PT8632 SDI TPG. The PT8633 Test Pattern generator also contains the complex "Philips" Circle and FuBK test patterns in both 525 and 625-lines, in 4:3 and 16:9 aspect ratios. Moving element synchronized to "Click" in the embedded sound, can be selected.

Output can be configured to include EDH, and embedded audio with a selection of test tones, silence, and levels.

- Source identification Text String: Three text strings with up to 16 characters can be added to the signal. Position on the screen can be selected to be standard, free or optimized for the black windows in the "Philips" pattern or FuBK patterns.

Full listing of signals in table 2.

Each generator has two outputs.

- Format: 270 Mb/s component, complies with ITU-R BT 656 and SMPTE 259M
- Data Format: Scrambled NRZI 270 Mbit/sec
- Output impedance: 75 Ohm
- Return Loss: >15 dB, 5 to 270 MHz
- Amplitude: 800 mV ± 10 %
- Jitter: <0.2UI
- Timing Range: ± 1 field
- Resolution: 37.5 ns (one half clock cycle on the 13.5 MHz clock)

SDI Test Pattern, extended

PT8632 SDI Test Pattern Generator, extended

This generator features an extended range of the commonly used test signals compared to the Basic SDI TSG.

The PT8632 Test Pattern Generator also contains the complex "Philips" test pattern in 625-lines, 4:3 aspect ratio. Output can be configured to include EDH, and embedded audio with a selection of test tones/silence and levels.

- Source identification Text String: Three text strings with up to 16 characters can

be added to the signal. Position on the screen can be selected to be standard, free or optimized for the black windows in the "Philips" pattern.

Full listing of signals in table 2.

Each generator has two outputs.

- Format: 270 Mb/s component, complies with ITU-R BT 656 and SMPTE 259M
- Data Format: Scrambled NRZI 270 Mbit/sec
- Output impedance: 75 Ohm
- Return Loss: >15 dB, 5 to 270 MHz
- Amplitude: 800 mV \pm 10%
- Jitter: <0.2UI
- Timing Range: \pm 1 field
- Resolution: 37.5 ns (one half clock cycle on the 13.5 MHz clock)

Basic SDI Test Signal

PT8639 Basic SDI Test Signal Generator

Contains the most commonly used test signals, e.g. colour bars, PLUGE, SDI checkfield, staircase, black, etc.

Output can be configured to include EDH, and embedded audio with a limited selection of test tones, silence, and levels.

Full listing of signals in table 2

Each generator has two outputs.

- Format: 270 Mb/s component, complies with ITU-R BT 656 and SMPTE 259M
- Data Format: Scrambled NRZI 270 Mbit/sec
- Output impedance: 75 Ohm
- Return Loss: >15 dB, 5 to 270 MHz
- Amplitude: 800 mV \pm 10%
- Jitter: <0.2UI
- Timing Range: \pm 1 field
- Resolution: 37.5 ns (one half clock cycle on the 13.5 MHz clock)

Analogue Test Pattern

PT8631 Analogue Test Pattern output

Contains a wide range of most commonly used test signals in PAL and NTSC, i.e., Colourbars, PLUGE, Multibursts, Multipulse, Ramp, Staircase, Testlines, Window and Flat field signals. The generator also contains the complex "Philips" Circle Pattern in both 525 and 625 lines, in 4:3 and 16:9 aspect ratios.

- Connector: BNC
- Output impedance: 75 Ohm \pm 0.5 Ohm
- Return Loss: >36 dB, to 5 MHz
- Sync amplitude: -300mV \pm 2% (PAL) or -286mV \pm 2% (NTSC)
- Video amplitude (100%):
 - 700mV \pm 1 % (PAL);
 - 714 mV \pm 1 % (NTSC).

- Timing range:
 - \pm 4 field (PAL)
 - \pm 2 field (NTSC)
- Timing resolution: 0.5° of subcarrier
- Sc-H phase: Default 0°, adjustment 180°, resolution <1°
- S/N Ratio: better than 60 dB unweighted up to 5 MHz
- Jitter: \leq 0.5 ns

Also the FuBK Pattern is available in 625 lines, 4:3 and 16:9 aspect ratios.

Source Identification Text string: Three text strings with up to 16 characters can be added to the signal. Position on the screen can be selected to be standard, free or optimized for the black windows in the "Philips" or FuBK patterns.

Full listing of characteristics in table 2

Audio Generator

PT8635 Dual AES3 Digital Audio Generator.

Two independent digital audio generators in one unit, with tone, silence or wordclock. Separate wordclock output is available. A second wordclock output can be implemented on request.

BNC Outputs: 2

- Single-ended in compliance to AES3id
- Output impedance: 75 Ohm \pm 20%
- Amplitude: 1.0 V \pm 10% into 75 Ohm

XLR output 1(2¹)

- Balanced in compliance to AES3 1992
- Output impedance: 110 Ohm \pm 20%
- Amplitude: 3 V_{pp} typical into 110 Ohm
- Rise and Fall Times: 10-30 ns
- Jitter: <20 ns

¹) If PT8637 Time Clock Input is installed only one XLR output is available.

Signal specification:

- Sampling Frequency: 48 kHz
- Data rate: 3.072 Mbit/s
- Coding: Linear PCM, 20 bit two's complement binary, bi-phase mark coding.
- Levels: Silence, 0, -9, -12, -15, -16, -18, -20 dB_{FS}
- Preemphasis: None
- Outputs signals:
 - Stereo 1 kHz
 - Stereo 800 Hz
 - Stereo 1 kHz with click in Ch.A
 - Stereo 1 kHz with normal click in Ch.B and long click in Ch.B
 - Dual 1 kHz in Ch A and 400Hz in Ch.B
 - Mono 1 kHz
 - Mono 1 kHz with click in Ch.A and Ch.B

Word-clock output:

- Single ended BNC.
- Output impedance: 75 Ohm \pm 10%
- Levels: High >2.3V; Low <0.2V into 75 Ohm
- TTL compatible when unterminated

Time Clock Interface

PT8637 Time clock Interface

Reference for the time clock

- VITC in genlock signal
- LTC on separate XLR connector
- Internal video clock reference
- When power is off: XTAL osc. with battery back-up.

The XLR input can be configured for a 1 sec. pulse input.

- LTC Input impedance: > 10kOhm
- LTC Input level: 0.8 - 5 V_{pp}
- Pulse input impedance: 1 kOhm \pm 10% (selectable internally: 50 Ohm \pm 10%)
- Pulse input level: 1.8 - 22 V_{pp}
- Pulse duration: 18 μ s - 0.7s

General Specifications

Power Supply

- Voltage: 90-250VAC
- Frequency 48 - 62 Hz
- Power consumption < 90 W maximum with options

Mechanical Data

- 19" rack mount cabinet
- Height: 44 mm (1.73")
- Width: 483 mm (19")
- Depth: 490 mm (19.3")
- Weight: 6 kg (13.2 lbs)

Environmental Conditions

- Storage temperature: -20° to +70°C (-68° to 158°F)
- Operating temperature: +5° to +45°C (41°-113°F)
- Humidity: Non condensing (IEC 721)

Electromagnetic compatibility

- Complies with EN50081-1 /1994 (emission) and EN 50082-1/1997 (immunity).
- Complies with FCC Rules & Regulations, Part 15, subpart J, level B (emission).

Safety

- Complying with IEC1010-1

Rear Panel

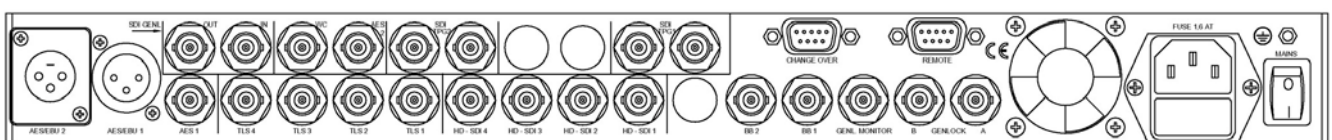

Ordering Information

Base units

PT5300HD	HD-SD VariTime™ Sync Generator, HD base unit, 4 tri-level sync outputs, 2 black burst outputs, genlock to BB, subcarrier, 5 MHz, and 10 MHz
PT5300SD	SD VariTime™ Sync Generator, SD base unit, 2 black burst outputs, genlock to BB, subcarrier, 5 MHz, and 10 MHz

Options

PT8604	Multiple Parallel Black Burst Output, 6 outputs
PT8606	SD-SDI Digital Genlock Module, 1 input
PT8608	Dual Black Burst Generator, 2 outputs
PT8609	SDI Black/Colour Bar Generator
PT8611	Quad Tri-Level Sync Generator, 4 outputs
PT8612	Quad HD-SD Serial Digital Generator, 4 outputs
PT8631	Analogue Test Signal Generator
PT8632	SDI Test Pattern Generator, Extended
PT8632/10	SDI Test Pattern Generator (Extended) FuBK 4:3
PT8633	SDI Test Pattern Generator, High end
PT8635	Dual AES3 digital audio generator, 2 XLR outputs, 2 BNC outputs, Wordclock output
PT8637	Time & Clock Interface
PT8639	SDI Test Signal Generator, Basic signals

DK-Technologies

