

wires to expose clean metal, reseating the connectors, and securely tightening all screws or nuts. Any wiring or switches that show a high voltage drop should be replaced.

#### 6. Testing Switch Operation:

Use the resistance of connectivity function to find a bad switch. With power removed from the circuit, set your meter to measure resistance or continuity and probe sides of the switch. Operate the switch and watch for a change on the meter display. If the display doesn't change, the switch is defective. (see figure 2)

If not, it may be time to replace the component completely. If you suspect a more serious problem, call a qualified certified automotive technician for help.

#### 7. Where to Go From Here:

With the help of the tips and techniques in this booklet, you should be able to troubleshoot most of the common electrical problems. When troubleshooting automotive electrical systems, it's important to use a logical process of deductive reasoning to solve the problem. Jumping to conclusions can be expensive and time consuming. Just use this simple approach: check for power, check fuses and switches, check connections, and check for good grounds.



99 Washington Street  
Melrose, MA 02176  
Fax 781-665-0780  
TestEquipmentDepot.com



### How-to Test it Yourself

# Automotive Electrical

Auto #11

#### Typical Problems:

Most automotive electrical problems can be traced to a bad connection or a failed component. High resistance ground connections can be one of the most frustrating of electrical problems. They can produce bizarre symptoms that don't seem to have anything to do with the cause, once you finally find it. The symptoms include lights that glow dimly, lights that come on when others should, gauges that change when the headlights are turned on, or lights that don't come on at all. A failed alternator, a bad battery, or a blown fuse can all result in things just not working at all.

#### Task Summary:

This booklet will help you diagnose and fix common electrical problems in your car. When troubleshooting electrical systems, it's important to use a logical process of deductive reasoning to solve the problem. This process is most important since, unlike mechanical devices, you can't see inside or dismantle the majority of electrical components to tell whether they're functioning. We'll start with the battery and charging circuit, then look at bad grounds and other electrical connections, then finish by checking for failed components.

#### Recommended Tools:

You will need a DMM that measures dc volts, ac volts, resistance, and continuity. You will also need a current clamp accessory that measures dc current. As an alternative, use a clamp-on multimeter that combines all the above measurement capabilities. It is assumed you have basic knowledge of how to make electrical measurements and how to operate a DMM or clamp meter. If not, you should start by reading "Basic DMM Measurements" and your DMM or clamp meter owner's manual.



## Step by step troubleshooting:

### 1. Measuring Battery Voltage:

If your battery becomes discharged it will be unable to provide sufficient voltage or current to the starter, hence the engine won't crank. The first step is to test the battery and charge it if necessary.

Verify that the connections to the battery look clean and are tight. With the engine off, bleed the surface charge from the battery by turning on the headlights for a minute. Now with the lights off, set your DMM to the dc voltage function, 20 volt range, and measure the voltage across the battery terminals by touching the red probe tip to the "+" terminal and the black probe tip to the "-" terminal. Use the chart below to determine the approximate percent charge on the battery. If the battery voltage reads low, the battery may be damaged or worn out, or the charging system is not working correctly. See below for how to verify the alternator is working. A more complete load test should be done to indicate battery performance under load and determine if the battery is damaged.

#### No-Load Test

Readings obtained at 80°F (27°C)

Voltage	Percent Charge
12.60V to 12.72V	100%
12.45V	75%
12.30V	50%
12.15V	25%

### 2. Verifying a Good Alternator:

To perform this test, the battery must be fully charged (see step 1). Run the engine at idle and verify that no-load voltage is 13.8 - 15.3. volts dc (check

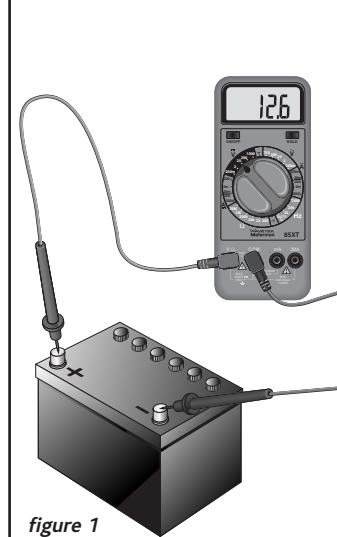

figure 1

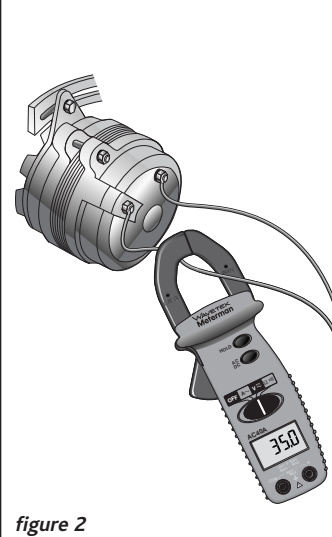

figure 2

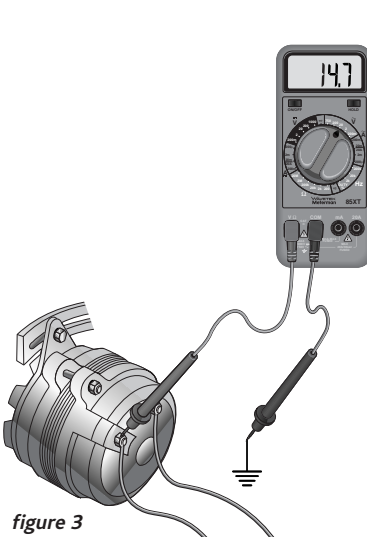

figure 3

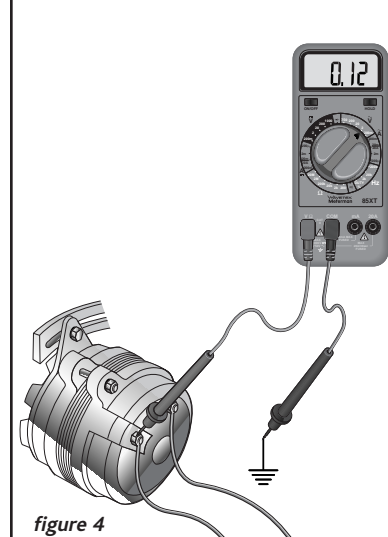

figure 4

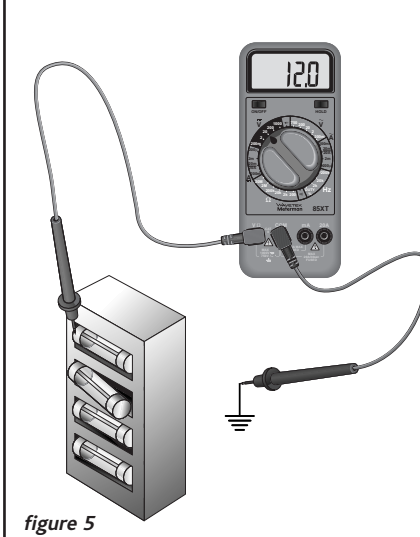

figure 5

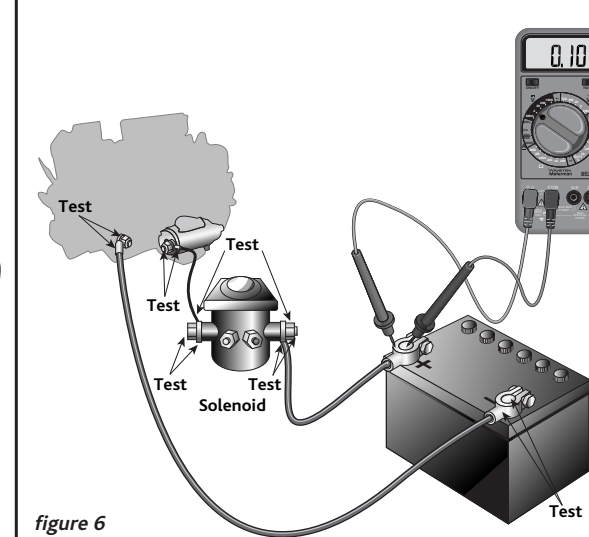

figure 6

# Diagnosing common automotive electrical problems

as in step 1). Next, load the alternator to rated output current by turning on as many accessories as possible (e.g. headlights, brake lights, heater fan, rear window defogger and lighter). Run the engine at a fast idle, about 2000 RPM. Check the output current of the alternator with a dc current clamp (see Figure 2) to see if it is at or near the rated output current. Now check the alternator output voltage. (see Figure 3) The alternator must maintain at least 12.6 volts dc output at rated alternator current output.

### 3. Checking Ripple Voltage:

The alternator generates ac voltage which is converted to dc voltage. The output of a properly functioning alternator will show a small amount of ac voltage called "ripple". A good alternator should measure less than 0.5 volts ac ripple with the engine running and loads applied.

Run the engine at fast idle and turn on accessories to load the alternator. Measure the ripple voltage by switching your DMM to the ac volts function, 2 volt range, and connecting the black

lead to a good ground (such as the engine block) and the red lead to the "BAT" terminal on the back of the alternator (not at the battery). (see figure 4) A reading higher than 0.5 volts ac may indicate damaged alternator diodes.

To rule out the wiring as the source of the trouble, check all the wire connections between the alternator and the battery terminals. Refer to Step 5, "Testing for Bad Connections" for details on performing a voltage drop test. A resulting voltage drop of 200 mV or greater requires that the wiring connectors need cleaning and tightening, or replacement.

If the wiring is OK, have the engine's charging circuit serviced.

### 4. Testing for Circuit Integrity:

Electrical devices need good, solid connections in order to operate properly. This is particularly true in automobiles since the power source is a battery. Vibration, temperature extremes, and corrosion from salt and rain can cause good connections to go bad in your car. Loose connectors,

build-up of rust and corrosion, broken wires, and damaged switches are all examples of bad connections.

If a device is not working properly, first check to make sure it is getting power. Set your DMM to the dc voltage function, 20 volt range. Connect the black lead to a good ground and probe with the red lead on the "+" input of the device. (Make sure the ignition switch is turned ON. Many accessories do not operate with the ignition turned off.) If the reading is zero, there is no power to the device. This could be an indication of a blown fuse.

To check for a blown fuse, first locate the fuse holder. This is usually a block about the size of a pack of cigarettes under the dashboard or in the engine compartment. Remove the cover. Use the diagram on the cover to locate the fuse that supplies power to the accessory or device you are testing. (see figure 5)

To test the fuse, set the DMM to the dc voltage function and connect

the black lead to a good ground, then probe both sides of the fuse for 12 volts dc. A good fuse will show 12 volts on both sides. A blown fuse will show 12 volts on one side only. If you cannot easily probe both sides of the fuse, as an alternative you can remove the fuse and check it for continuity. Set the DMM to the continuity function and probe one side with the black lead and the other side with the red lead. A good fuse will sound the continuity beeper and show almost zero ohms of resistance. A bad fuse will not sound the beeper and will show "OL" for resistance. Replace any blown fuse only with one of the same type and current rating.

### 5. Testing for Bad Connections:

A bad, or high resistance, ground connection robs some of the voltage needed by the device you want to run. If a device is not operating properly, check all the connections leading up to the device, and back to the battery. Suspect connections include terminal posts, crimp connectors, bulb sockets, switches, and even the wiring itself. (see figure 6)

To check for a bad connection, you need to measure the voltage drop across the connection. The higher the voltage drop, the worse the connection. Current must be flowing for the meter to register the voltage drop found. Turn ON the device (and the ignition, if necessary). Set your multimeter to the dc voltage function, 3 volt range. Connect the red lead to the side of the connection nearer the battery positive (+) terminal and the black lead to the side nearer the battery negative (-) terminal or ground.

The measured voltage drop should not exceed the following:

300 mV (0.3 V)	Switch
200 mV (0.2 V)	Wire or cable
100 mV (0.1 V)	Ground
0 mV to < 50 mV	Sensor Connections
0.0 V	Connections

If you find a higher voltage reading you have a bad connection. Try cleaning the contacts by removing any rust or corrosion, scraping the metal or

(continued on back)

## Work safely!



Electricity can be dangerous. Protect yourself and your car by remembering to follow a few simple rules when working with electrical circuits:

- Make sure your meter is working with a 3-point check: Measure a known live circuit, next measure the circuit you're working on and finally re-check the known live circuit.
- Only use a meter that has the proper voltage ranges for the job at hand and make sure the meter has the proper safety ratings and protection.
- Use caution when reaching inside the engine compartment. Parts of the engine may be very hot, and the fan may start automatically

- Don't wear loose fitting clothing, jewelry or a tie that can become caught in moving pulleys and belts. Make sure test leads are safely out of the way of all moving parts of the engine.