

SERIES 40A ACRYLIC INCLINED

DESCRIPTION

The new Acrylic Inclines* are the latest of high quality precision manometers available from Meriam Instrument. Series 40AM and 40AX are 2 to 4 times more accurate than similar competitive units, and are suitable for lab and general industry environments.

The unique Fluid Meniscus Amplification System makes the meniscus 4 times larger than others. When combined with bright white non-glare scales with sharp black graduations and anti-parallax mirrored reference strip, these inclines are most easily read — correctly! All mastered scales are traceable to NBS.

These precise pressure, draft, vacuum, flow, velocity, etc. measurement devices are backed by a company who has been the leader in manometry since 1911.

*Patent Pending

FEATURES AND BENEFITS

- **High Accuracy** —Model 40AM...±1.0% FS
—Model 40AX...±0.5% FS
- **Better Readings** —Fluid Meniscus Amplification System.
—Bright white non-glare scales with sharp black graduations.
—Anti-parallax mirrored scale reference strip.
—All units have fluid level zero adjustment mechanism.
—Mastered scales traceable to NBS.
- **Easily Read** —Portable with rugged carrying case option.
—Magnetic, table or wall mounting available.
—Integrally mounted (precisely positioned) leveling bubble.
—Only two models and fluids cover ranges from 1" to 6" H₂O.
—Custom engineered scales for virtually any application

DIMENSIONS

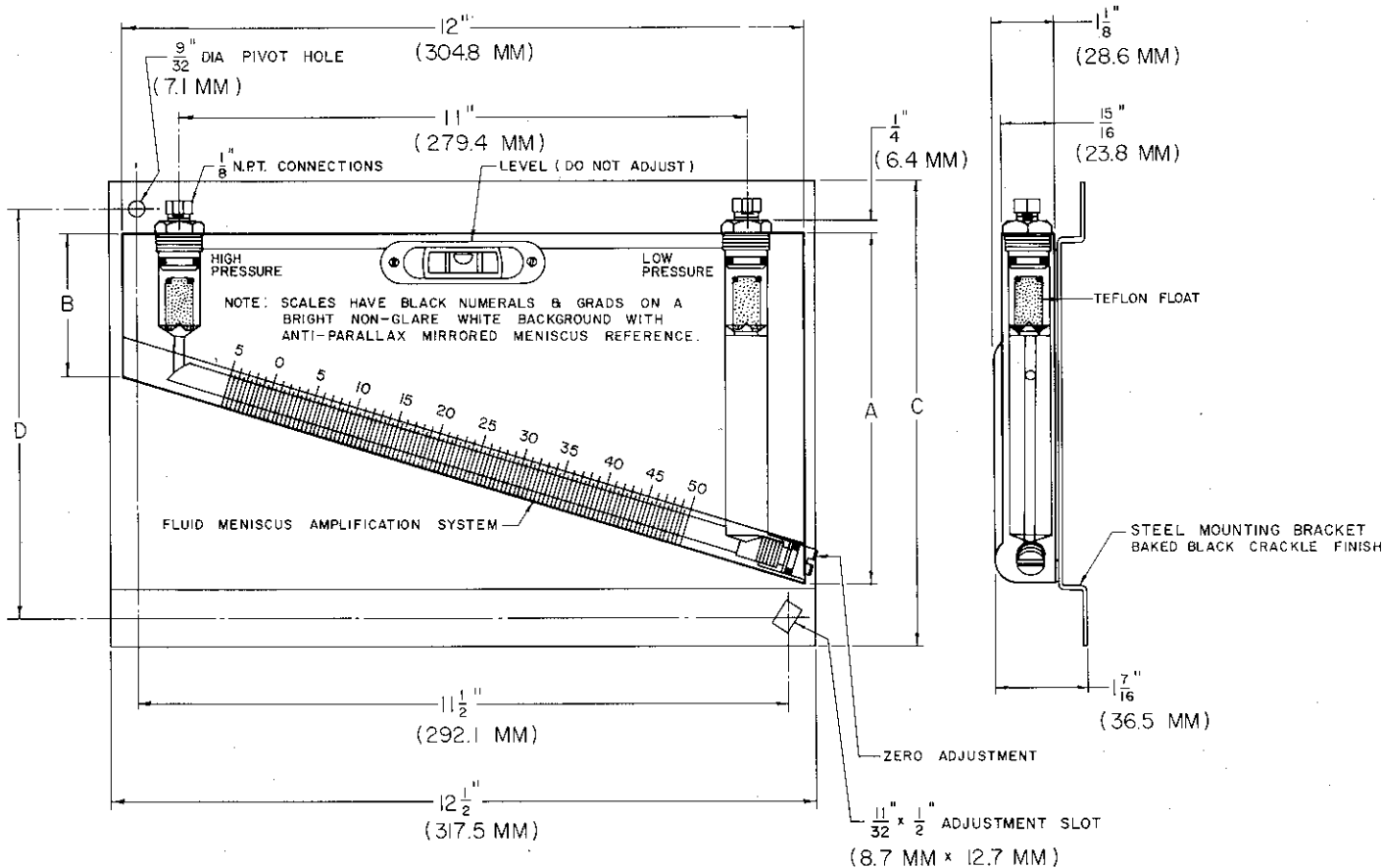

MODEL NO.	VERTICAL DIFFERENTIAL*		MEASUREMENT RANGE USING 2.0 FLUID		A		B		C		D	
	INCHES	(MM)	INCHES	(MM)	INCHES	(MM)	INCHES	(MM)	INCHES	(MM)	INCHES	(MM)
40AM10	1.1"	28	2.2"	56	3 ³ / ₄ "	95.3	2 ⁵ / ₁₆ "	74.6	5 ³ / ₄ "	146.1	4 ³ / ₄ "	120.7
40AM10	3.2"	81	6.4"	162	6 ³ / ₁₆ "	157.1	2 ¹ / ₂ "	63.5	8 ⁷ / ₁₆ "	208	7 ⁷ / ₁₆ "	182.5
40AX10	1.1"	28	2.2"	56	3 ³ / ₄ "	95.3	2 ⁵ / ₁₆ "	74.6	5 ³ / ₄ "	146.1	4 ³ / ₄ "	120.7
40AX10	3.2"	81	6.4"	162	6 ³ / ₁₆ "	157.1	2 ¹ / ₂ "	63.5	8 ⁷ / ₁₆ "	208	7 ⁷ / ₁₆ "	182.5

*Also measurement range using 1.0 fluid.

SPECIFICATIONS

	Model 40AM	Model 40AX
Accuracy	±1.0 F.S.	±0.5% F.S.
Max. Pressure PSIG (Bar)	100 (6.9)	100 (6.9)
Max. Temperature °F (°C)	150 (65)	150 (65)
Connections	1/8" FNPT (plugs included)	
Mounting Type		
A Magnetic	Standard w/unit	Standard w/unit
B Table	Optional	Optional
C Wall	Optional	Optional
Scales	English-Metric	English-Metric (any units within the measurement range)

TYPICAL SPECIFICATION

An Acrylic Inclined Manometer shall be provided for the measurement of (Pressure, Draft, Flow, Vacuum, Velocity, etc.). Accuracy of the manometer shall be not less than (±1.0% FS, Model 40 AM; ±0.5% FS, Model 40AX). Materials of construction shall be suitable for a maximum pressure of 100 PSIG and temperature of 150°F. Process connections shall be 1/8" FNPT. (Magnetic, table, wall) mounting is required.

Scales shall be photo reproduced having a bright white non-glare background with sharp black graduations. For optimum resolution, scales shall not be less than 8" in length nor have less than 100 graduations. Engineering units shall be (specify). Mastered scales shall be traceable to NBS.

An anti-parallax mirrored meniscus reference strip and fluid meniscus amplification (image not less than 5/16") shall be provided for ease of reading.

Integral front mounted, precision positioned bubble level and fluid level zero adjustment mechanism must be provided.