

Three and Four Pole Earth Ground-Tester **SATURN GEO plus**

- Easy handling due to single button concept
- Large display with 25mm digits and problem indicator
- 2-pole AC resistance measurements
- 3-pole and 4-pole earth measurements (fall of potential)
- Selective earth measurements in meshed systems
- Stakeless earth measurements with two current clamps
- Monitoring of probe and auxiliary earth electrode
- Extremely robust due to protective rubber holster
- Splash water proof - IP 56



Description

SATURN GEO plus is a versatile, easy to handle and very robust earth/ground-tester, covering all traditional earth measurements up to the innovative method of stakeless earth testing without the use of earth stakes.

It is designed for electricians and for people who plan, erect or check complex earthing or lightning protection systems and for day-to-day usage in rough environments.

The very large display ensures optimum readability even under dark conditions or from big distances.

Due to the single button user interface, professional and complex earth measurements, like the selective or the stakeless earth measurement using current transformers, become an easy task.

Only one big, heavy duty button to ensure ease of use:

- Select function

- Press **START**

- Read result

Uncertainties in the measurement values or wrong connections are immediately recognized by the **SATURN GEO plus** and a warning message will prompt the user.

Applications:

- Earth resistance measurements of various installations (high voltage pylons, buildings, cell phone substations, RF transmitters, pipelines, tanks, industry etc)
- Inspection and planning of lightning protection systems, meshed and complex earth systems, equi-potential bus bar systems, ...

SATURN GEO plus is suited for all earth/ground measurements including IEC 1024, ENV 61024, DIN VDE 0185, ÖVE-E 49 .

This instrument has been manufactured to comply with quality assurance system DIN ISO 9001. The compliance with the actual EMC-regulations is documented by the attached CE-sign.

Order reference - scope of delivery

SATURN GEO plusA 1885 06711

- 1 SATURN GEO plus incl. rubber holster
- 6 alkaline AA - type (LR6) batteries
- 2 measuring leads 1,5 m with test prods
- 1 shorting jumper for 2-pole-measurements
- 2 alligator clips
- 1 carrying belt with hooks
- 1 operating instructions with CE-certificate
- 1 LEM NORMA test certificate

Recommended accessories:

Set for 3-pole earth measurements:A 6045 10302

- 2 x 1 earth stake.....A 6045 10350
- 1 cable reel with 25m wire.....A 6045 05102
- 1 cable reel with 50m wire.....A 6045 05103

Set for 4-pole earth measurements:A 6045 10301

- 4 x 1 earth stake.....A 6045 10350
- 2 x 1 cable reel with 25m wire.....A 6045 05102
- 1 cable reel with 50m wire.....A 6045 05103

Set for selective earth measurements:A 6045 10305

- 1 pc. current clamp 100 A ACA 6805 01007
- 1 pc. cable for clamp connection.....A 6002 09200

Set for stakeless earth measurements:A 6045 10307

- 1 pc. current clamp 100 A AC (sensing)A 6805 01007
- 1 pc. current clamp PR1200ACI (inducing).....60.95.62.001.0
- 1 pc. shielded cable for clamp connection...A 6002 09300

Carrying case for SATURN GEO plus

- For Saturn GEO plus and accessories.....A 6030 00530
- For Saturn GEO plus and accessories for clamp measurementsST0010Z

Applied regulations and standards

- | | |
|-----------|--------------|
| IEC 61557 | IEC 61000 |
| IEC 61010 | IEC 654 |
| EN 61326 | DIN ISO 9001 |



APPLICATIONS

Principle of measurement

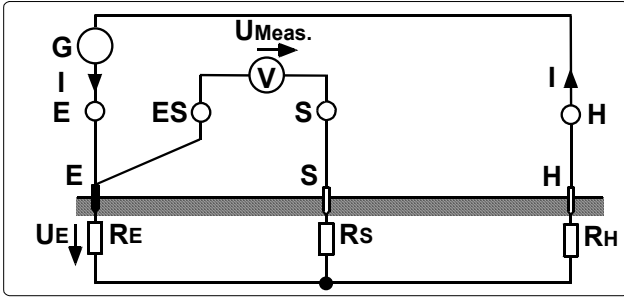

Practical test hook-up

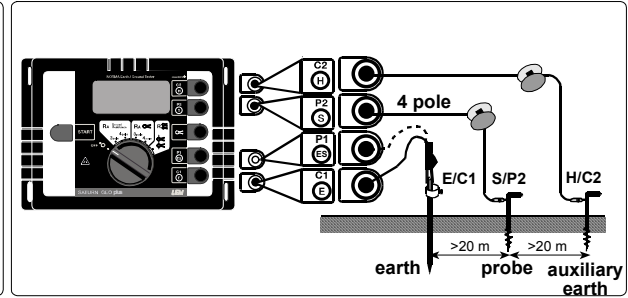

3 pole- and 4 pole-measurement

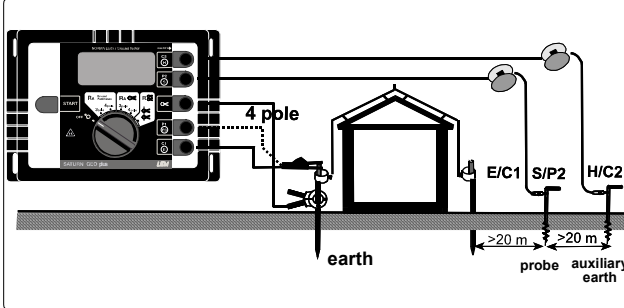

Earth resistance measurement at high voltage pylons

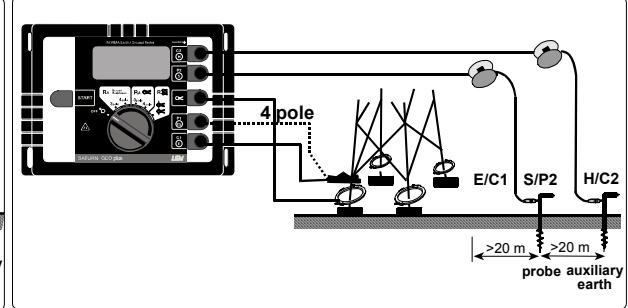

Stakeless earth measurement

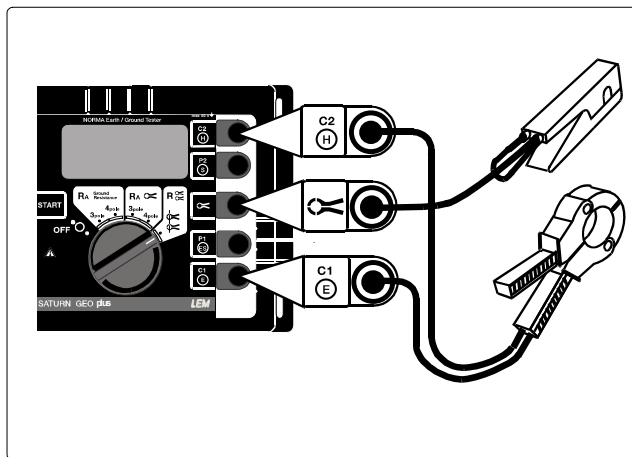

Selective Measurement e.g.: at high voltage pylons

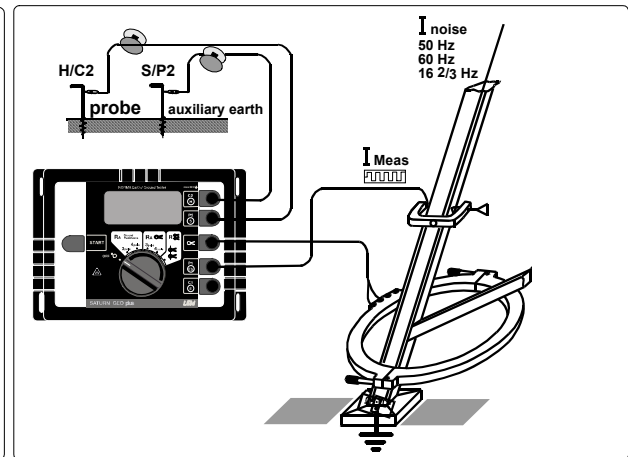

Stakeless measurement of earth loops

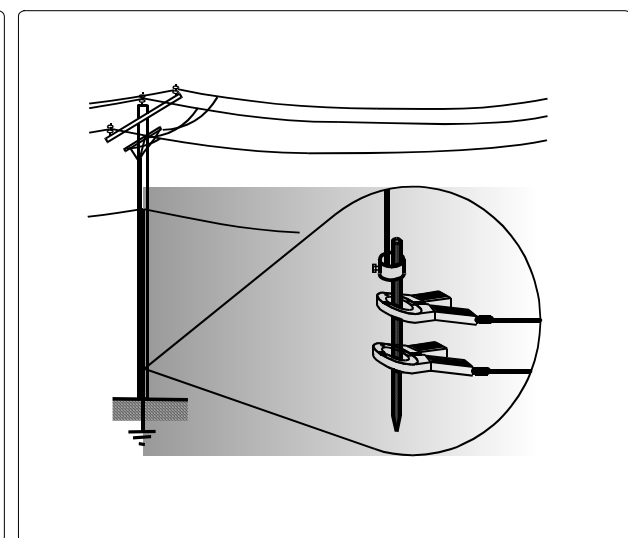
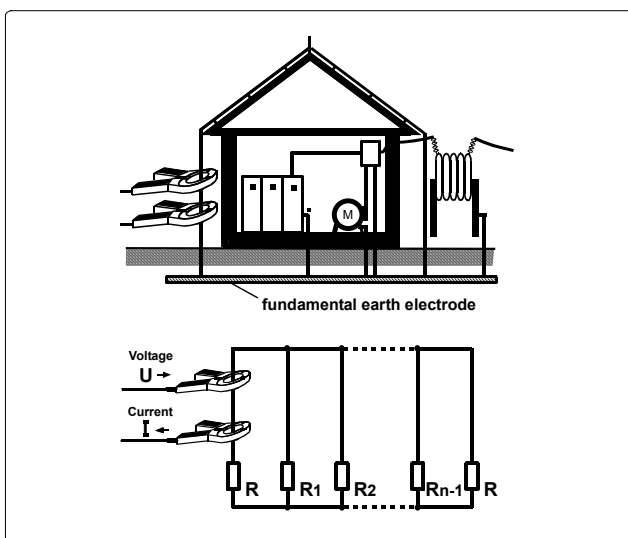

SPECIFICATIONS

Robust instrument, designed for tough environmental conditions, waterproof (rubber protective cover, IP56).

General:

Display: 1999 digit LC-display with special symbols, digit height **25 mm**, fluorescent backlight

User interface: Instant measurement through **TURN and START - one button concept**. The only operating elements are rotary switch and START button.

Temperature ranges:

Working temp.: -10° C ...+50° C (+14° F ...+122° F)

Operating temp.: 0° C ...+35° C (+32° F ... +95° F)

Storage temp.: -20° C ...+60° C (-4° F ...+140° F)

Reference temp.: +23° C ±. 2° C (+73° F ± 4° F)

Temp. coefficient: ± 0,1 % of reading / K

Intrinsic error: Refers to the reference temperature range and is guaranteed for 3 years.

Operating error: Refers to the operating temperature range and is guaranteed for 3 years.

Climatic class: C1 (IEC 654-1), -5° C...+45° C, 5%...95% RH

Protective type: IP56 according to EN 60529

Safety: Protection by double and/or reinforced insulation. 

EMC (Emission): IEC 61326-1:1997 Class B
CISPR16 (CISPR22), CISPR16-1

EMC (Immunity): IEC61326-1:1997
IEC 61000-4-2 8 kV (air) perf. criteria B,
IEC 61000-4-3 3 V/m perf. criteria A,
IEC 61000-4-4 0,5 kV perf. criteria B
IEC 61000-4-5 1 kV perf. criteria B
IEC 61000-4-6 3 V perf. criteria A
IEC 61000-4-8 Level 4, 30A/m perf. criteria A

Quality system: developed, designed and manufactured according to DIN ISO 9001

External voltage: Max. U_{ext} = 24 V (AC + DC), measurement inhibited for higher values

U_{ext} rejection: >120dB (16²/₃, 50, 60, 400Hz)

Measuring time: typical 6 sec

Max. overload: 250 V_{rms}

Auxiliary power: 6 x 1,5 V mignon cells alkali-manganese (type AA LR6)

Battery life span: typical > 3000 measurements

Dimensions: 240 x 180 x 110 mm

Weight: 1,1 kg (including batteries)

R_A 3-pole ground resistance measurement (IEC 1557-5)

Range	Intrinsic error	Operating error
0 Ω ... 20 kΩ	±(2% of rdg + 3 dig)	±(5% of rdg + 3 dig)

Measuring principle: Current/voltage

Measuring voltage: U_m = 48 Vac.

Short-circuit current: > 50 mA

Meas. frequency: 128 Hz (125 Hz on request)

Probe resistance (R_s): max. 100 kΩ

Auxiliary earth electrode resistance (R_h): max. 100 kΩ

Monitoring of R_s and R_h with error indicator.

Automatic range selection.

R_A 4-pole ground resistance measurement (IEC 1557-5)

Range	Intrinsic error	Operating error
0 Ω ... 20 kΩ	±(2% of rdg + 3 dig)	±(5% of rdg + 3 dig)

Measuring principle: Current/voltage

Measuring voltage: U_m = 48 Vac.

Short-circuit current: > 50 mA

Measuring frequency: 128 Hz (125 Hz on request)

Probe resistance (R_s+ R_{es}): max. 100 kΩ

Auxiliary earth electrode resistance (R_h): max. 100 kΩ

Monitoring of R_s and R_h with error indicator.

Automatic range selection.

3-pole selective ground resistance measurement (R_A)

Range	Intrinsic error	Operating error
0 Ω ... 20 kΩ	±(7% of rdg. + 3 dig)	±(10% of rdg + 5 dig)

Measuring principle: Current/voltage (with external current transformer)

Measuring voltage: U_m = 48 VAC.

Short-circuit current: > 50 mA

Measuring frequency: 128 Hz (125 Hz on request)

Probe resistance (R_s): max. 100 kΩ

Auxiliary earth electrode resistance (R_h): max. 100 kΩ

Monitoring of R_s and R_h with error indicator.

Automatic range selection.

Measurement is not executed if the current through the current transformer is too low.

4- pole selective ground resistance measurement (R_A)

Range	Intrinsic error	Operating error
0 Ω ... 20 k Ω	$\pm(7\%$ of rdg + 3 dig)	$\pm(10\%$ of rdg + 5 dig)

Measuring principle: Current/voltage (with external current transformer)

Measuring voltage: $U_m = 48$ VAC.

Short-circuit current: > 50 mA

Measuring frequency: 128 Hz (125 Hz on request)

Probe resistance (R_s): max. 100 k Ω

Auxiliary earth electrode resistance (R_h): max. 100 k Ω

Monitoring of R_s , and R_h with error indicator.

Automatic range selection.

Measurement is not executed if the current through the current transformer is too low.

Stakeless ground loop measurement (R)

Range	Intrinsic error	Operating error
0 Ω ... 200 Ω	$\pm(7\%$ of rdg. + 3 dig)	$\pm(10\%$ of rdg + 5 dig)

Measuring principle: Stakeless measurement of resistance in closed loops using two current transformers

Measuring voltage: $U_m = 48$ VAC (primary)

Measuring frequency: 128 Hz (125 Hz on request)

Noise current (I_{ext}): max. $I_{ext} = 10$ A AC ($R_a < 20 \Omega$)
max. $I_{ext} = 2$ A AC ($R_a > 20 \Omega$)

Automatic range selection.

The specifications at stakeless ground loop measurements are only valid when used in conjunction with the recommended current transformers at the minimum distance specified (> 10 cm).

Test Equipment Depot - 800.517.8431 - 99 Washington Street Melrose, MA 02176

FAX 781.665.0780 - TestEquipmentDepot.com