



Article number: EO 0620GDF
Version number: Revision E
Date: 08 / 2004

**The manufacturer reserves the right to
change any information without notice.**

© LEM HEME, All rights reserved

Table of Contents

- 1. General 5**
 - 1.1 Power Quality Analysis..... 5
 - 1.2 Safety Instructions..... 6
 - 1.3 Standard and Optional Accessories 9
 - 1.4 Software and Information CD 10
- 2. Putting your Analyser into Operation..... 11**
 - 2.1 Accessories 11
 - 2.2 Carrying Belt 11
 - 2.3 Control Elements, Display 12
 - 2.4 Basic Adjustments (Menu) 15
 - 2.4.1 Menu Structuring 15
 - 2.4.2 Parameter Configuration 18
- 3. Measuring Functions 21**
 - 3.1 Overview 21
 - 3.2 Connecting the Analyser 22
 - 3.3 Volts / Amps / Hertz..... 24
 - 3.4 Power 26
 - 3.5 Events 29
 - 3.6 Harmonics 31
 - 3.7 Waveforms 33
- 4. Analyst 3P Software 34**
 - 4.1 Installing Analyst 3P Software 34
 - 4.2 Starting PQLog View 34
 - 4.3 Using PQLogView 35
 - 4.4 Recording measurement data with ANALYST 3P 36
- 5. Specific Data of the Analyser 39**
 - 5.1 Power Supply and Replacing the Battery Pack 39
 - 5.2 Maintenance and Warranty 41
 - 5.3 Calculation of the Measured Variables 42
 - 5.4 Technical Specification..... 44

1. General

1.1 Power Quality Analysis

With this analyser you have acquired one of our high-quality, efficient and durable multiple purpose test instruments. We thank you for your confidence.

By monitoring the voltage quality criteria, the final customer receives important information about the quality of his power network as provided by the electricity producer. With this Analyser you obtain the certainty that the power quality corresponds to the EN50160 standard.

It is necessary to check the supply voltage regularly in order to ensure the perfect functioning and working of the growing number of electronic devices. In connection with the liberalisation of the energy market "Voltage Quality" is also becoming more important for energy producers and final customers.

This device has been optimised for the fast identification of disturbances in the power network.

With the help of the clear representation of all relevant parameters, it becomes simple to detect systematic network problems.

Therefore the analyser was developed in particular for plant electricians and electrical installers, who have an important role during the recovery of disturbances of the power distribution system.

NOTE: FLASH TECHNOLOGY

Your Analyst 3P is equipped with Flash Technology. This enables you to perform firmware updates. Please use the Windows Flash Update utility to do this. You will find it on the Analyst CD-ROM.

Please find the most recent firmware - which is compatible to your instrument's hardware - on the LEM Homepage.

<http://www.lem.com>

1.2 Safety Instructions

Please read this section carefully. It makes you familiar with the most important safety instructions for handling your device.



Warning

Open the device only to replace the accumulator package (see chapter 4.1). Opening the device can lead to electrical shocks. Therefore the device has to be separated from all live sections before opening. Also disconnect all test leads before using the RS232 interface. Maintenance work can only be done by qualified service personnel.



Warning

Current probes must comply to IEC 61010-2-032 category A and must be designed for 600V CAT III. If flexible current probes are used, the conductor to be enclosed by the probe and the adjacent conductor must be connected strain-free, or suitable protective gloves must be worn.

Important

This power quality analyser may only be used and handled by qualified personnel.

Protect the device against wetness and humidity, so that the device does not suffer damage.

The plug and socket connection for the voltage input is designed for 600V CAT III. The maximum voltage between outer conductor and earth potential must not exceed 600V. With multi-phase connections, the voltage between the outer conductors of the system to be measured may not exceed 800V.

Warning

When connecting current circuits, the corresponding measuring lines must first be connected to the base unit and then to the current sensor to prevent the risk of electric shock in case of false connection.

Please use only the provided original accessories.

Especially the original power adapter must be used since it is a safety-relevant component! Please use only the supplied original adapter.

Symbols:



Protective earth



CE Certificate



Warning of danger (read the documentation)



Double insulation according to IEC 61010-1; Protective Class II; 600V CAT III



DC voltage

Qualified Personnel

These persons have the special know-how about the manufacturing, assembly, connections and operation concerning these instruments. Adequate qualifications are the following:

- Having received training and authorization to switch on/off, earth and mark circuits and devices in accordance with the safety standards of electrical engineering.
- Training or instruction in accordance with the standards of the safety engineering in maintenance and use of appropriate safety equipment.
- Training in first aid.

1.3 Standard and Optional Accessories

Contents of delivery	Order number
ANALYSER Basic: Basic unit 3-phase, voltage test leads 3-phase, 4 Dolphin clips, NiMH-battery-package, mains adapter, protective holster, carrying belt, RS232 interface	SH0620A
ANALYSER Set + LEM-flex set 3- phase + carrying case	EP0621A
LEM-flex set 3-phase 15/150/3000A with 7 pin plug (delivered with ANALYSER set only)	SX8315A
Voltage test leads 3-phase, 2 m	E438080005
NiMH – battery package, 2700mAh / 7,2V (built-in)	EP0610A
Transport and protection case (delivered with ANALYSER set only)	EP0611A
Operating instructions English, German and French	EO 0620GDF
Operating instructions English, Spanish and Portuguese	EO 0620ESP

Accessories and services	
Description	Order number
Voltage test leads 3-phase, 2 m	E438080005
Voltage test leads 3-phase, 2 m, UK- colours	E438080011
Voltage test leads 3-phase, 2 m long, USA-colours	E438080018
Connector cable with Euro-plug for single phase applications	E438080015
LEM-flex 3 phase 15/150/3000A with 7 pin plug	SX8315A
Set of current clamps 10A 3-phase	SX8350A
Set of current clamps 50A / 5A 3-phase	SX8450A
Set of current clamps 200A 3-phase	SX8320A
Dolphin clamp, blue	EP325Z
Dolphin clamp, red	EP326Z
Dolphin clamp, black	EP327Z
Minigripp, black, insulated	EP0312Z
Certificate A3P - ASC 02 (LEM-certificate with list of calibration points) for ANALYST 3P	EP0620A

Description	Order number
Power adapter (Euro)	EP0612A
Adapter plug UK	EUROCONV
Power adapter US	EP0612U
Operating manual English, German and French	EO0620GDF
Operating manual English, Spanish and Portuguese	EO0620ESP
Carrying case	EP0611A

Please pay attention upon delivery. Should your analyser have been damaged during transport you have to call this to the attention of the deliverer immediately. The damage must also be noted in the delivery documents.

In case of damage, please send your device back to us but only with the original packaging.

Please check all the accessories for completeness according to the previous table.

1.4 Software and Information CD

The CD delivered with the Analyser contains additional, important information. This includes:

- A demonstration of the download, analysis and reporting software PQLogView.
- Information on upgrading your analyser (for future reference)
- Datasheets and manuals on LEM Portable Power Quality Products
- A complete catalogue of LEM Instrument Products

2. Putting your Analyser into Operation

Note:

The analyser is delivered with an empty battery pack. Please charge the battery before the first operation or use the provided charging adapter at the beginning. (for more Information see section "Power Supply and Replacing the Battery Pack").

2.1 Accessories

Optional accessories like LEM-Flex or current clamps will be detected by the device via an auto-detection feature, which is activated once the device is turned on.

It is **important** to turn the device on once accessories have been changed to avoid possible discrepancies between the set accessories and the newly connected accessories.

2.2 Carrying Belt

If you would like to use your analyser as a carry-on, you can use the carrying belt. You can see in detail from the following figure, how you can fasten it to the device and adapt the length.

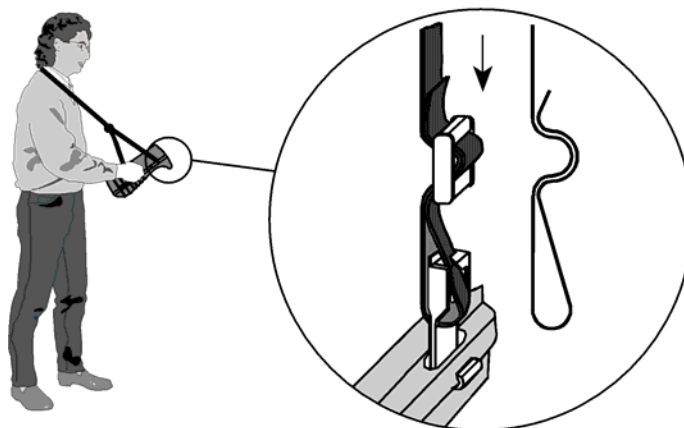

2.3 Control Elements, Display

In this section we will make you familiar with some basic control elements, like the display and the connections of your measuring instrument before the first measurement.

Put your device into operation by turning the rotary switch in clockwise direction. In the LC display (function display) you can read the selected measuring function for each case.

Display Symbols

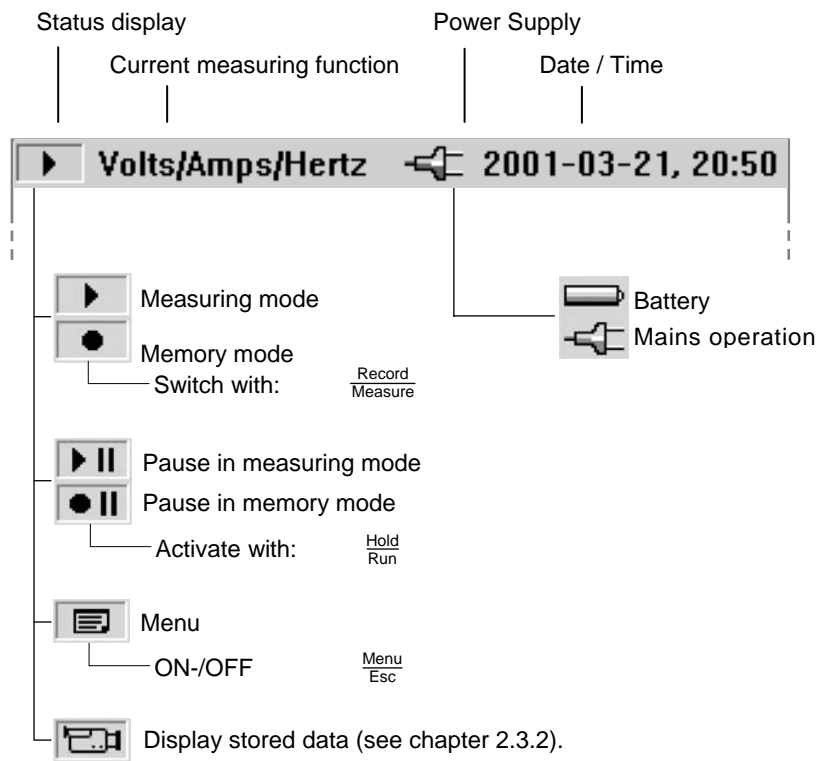

Description of the Control Elements:

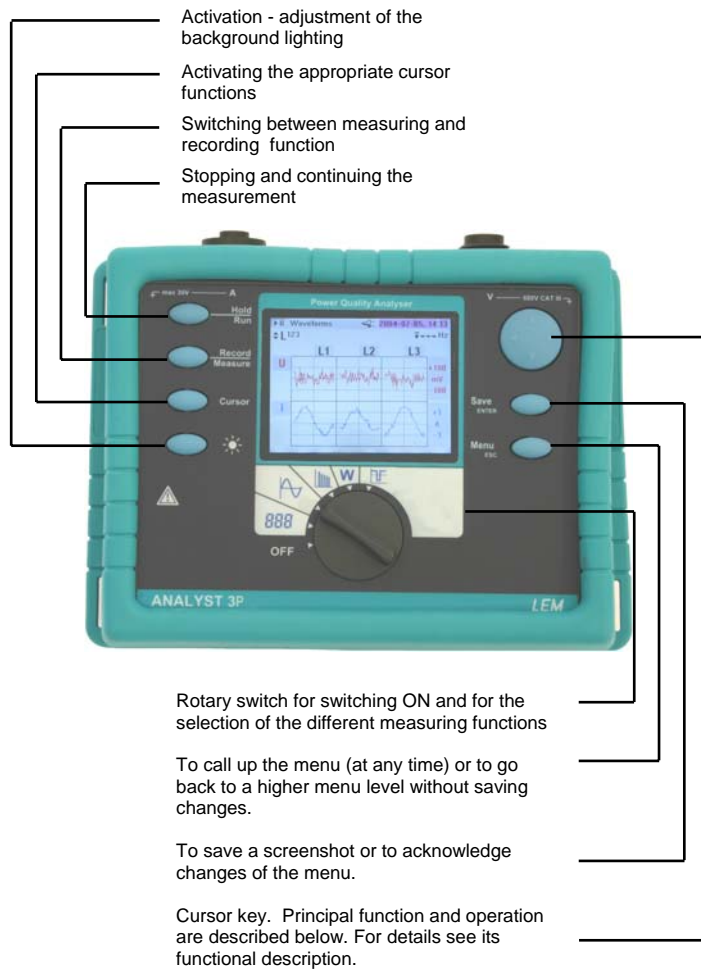

Note:

The symbols occurring in this operating instruction '⬆' and '⇄' correspond to the respective directions of the cursor keys.

Using the SAVE and CURSOR keys :

The SAVE and CURSOR keys are activated once you are in *HOLD mode*.

Pressing the SAVE key will save the current picture as a screenshot.

Since it is a screenshot, a saved picture cannot be modified or edited with the cursor.

Pressing the CURSOR key will go into cursor mode.

Pressing the key ⇄ will move the cursor and the current values can be read on the display.

Pressing the CURSOR key in the recording mode will set a reference cursor.

Screenshots can also be taken in cursor mode.

Pressing ESC will exit the cursor mode and return to the hold mode.

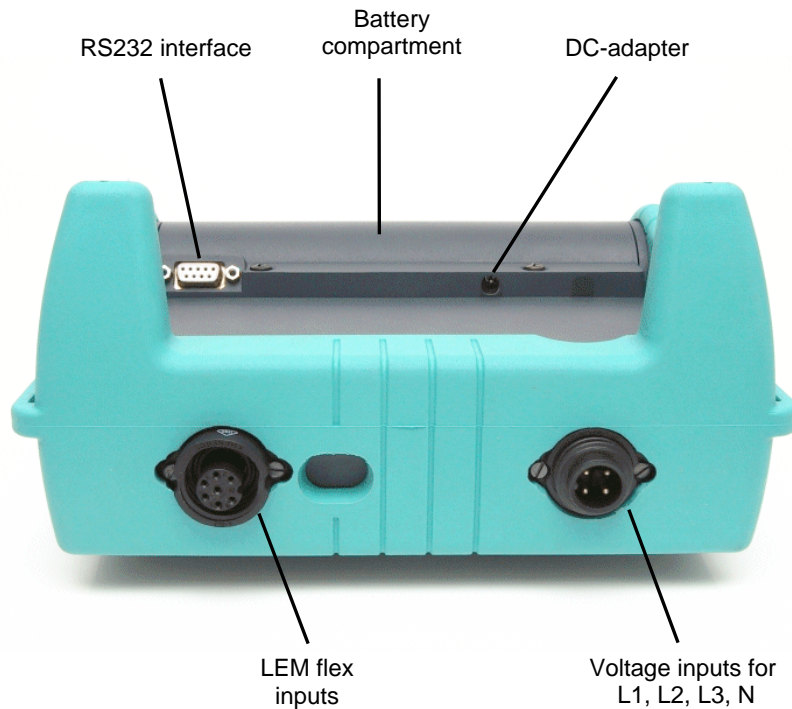
Connections:**RS-232 Interface:**

The serial RS232 interface is used for communication with an external PC. The stored measurement data can be read in and analysed comfortably. Through this interface a firmware update can be executed.

2.4 Basic Adjustments (Menu)**2.4.1 Menu Structuring**

All basic adjustments of your measuring instrument are to be made over the main menu. You can call this at any time with the key: . If you push it again you will return to the previous display.

Short overview of the Menu:

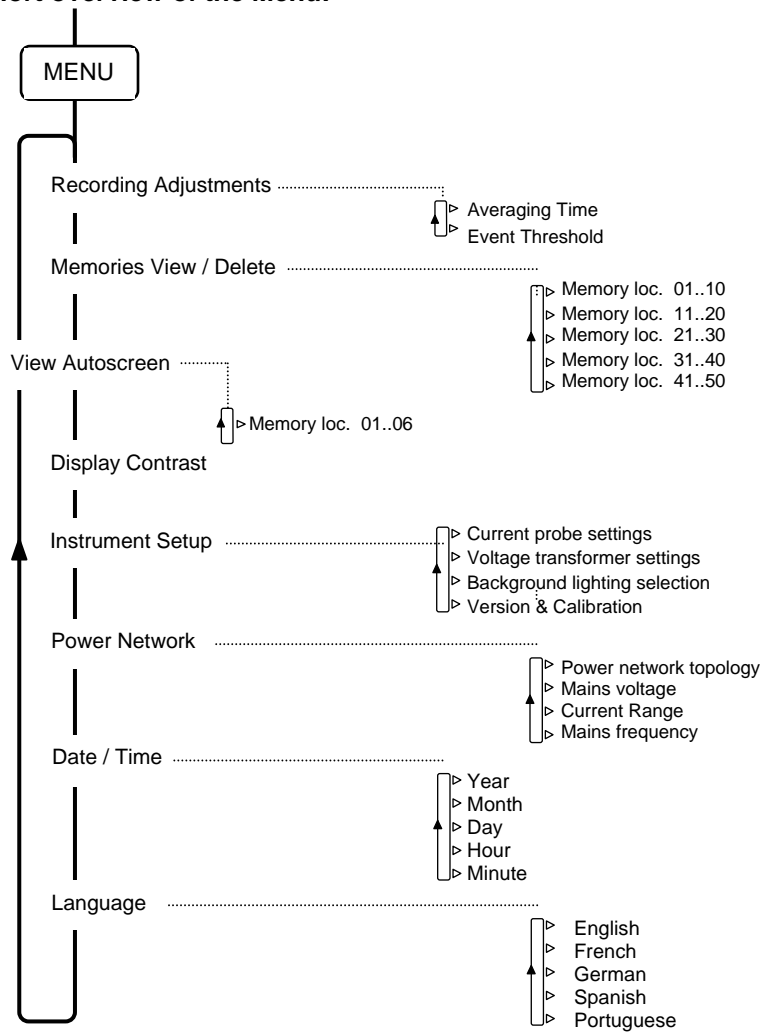

Basic Operation:

The following examples show how to select parameters in the menu.

- Entering the main menu: $\frac{\text{Menu}}{\text{Esc}}$

- Selecting menu options with the cursor keys: \updownarrow

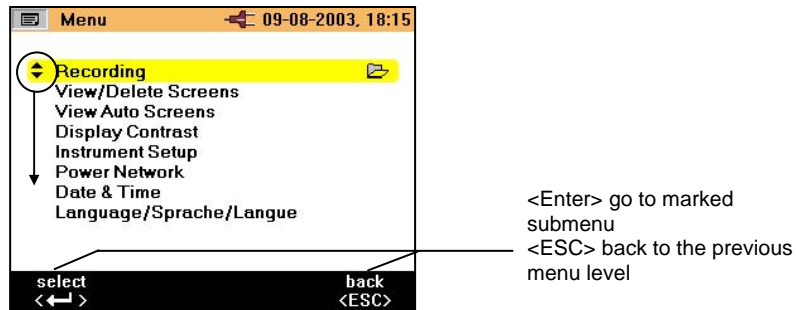

Changing parameters:

- The displayed parameters can be modified with the arrow keys (in levels of the preset values).
- If values are not preset you can modify them by using the cursor keys. With \leftarrow you can select the decimal place and with \updownarrow you can modify the number.

Note:

Selected parameters are stored in the memory with $\langle \text{Enter} \rangle$. With $\langle \text{ESC} \rangle$ the adjusted value can be rejected at any time.

2.4.2 Parameter Configuration

- Recording Adjustments (available in Hold mode only)

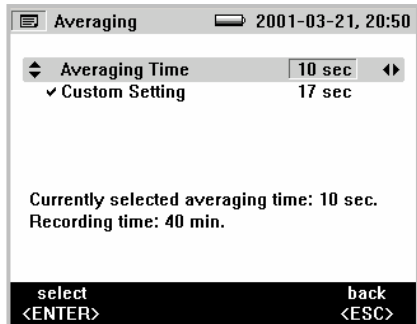

If you call the recording menu, then you can select between two further submenus: Menu for adjusting the averaging time (figure above) and for adjusting the event threshold (figure below) in recording adjustments.

In the menu "Averaging Time" you select the time over which the measuring data are to be averaged. You can also select these values from the predefined values for averaging time.

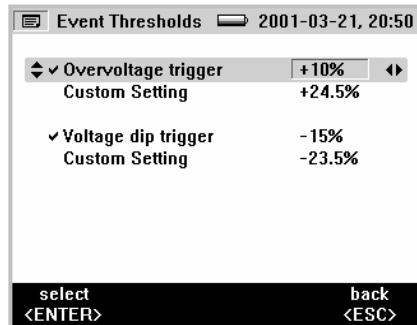

With "Custom Setting" you can choose any averaging time value. Depending upon the selected averaging time, maximum available recording time is indicated in the display at the same time. Up to 1440 averaging intervals can be recorded with the record function.

By selecting the menu "Event Thresholds" you can select the threshold voltage at which the recording is to be started (see also chapter 3.6).

- View/Delete Screenshots

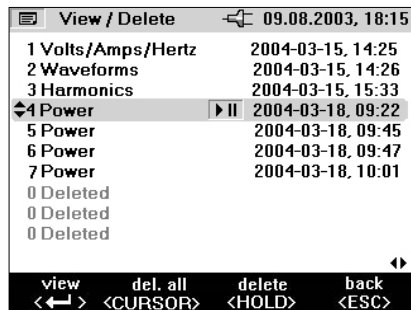

Select one of the saved screenshots. Press ENTER to view it. All screenshots include the date and time and the measuring mode, in which they were saved. Each page lists 10 events.

Use the ⇐ to change the page.

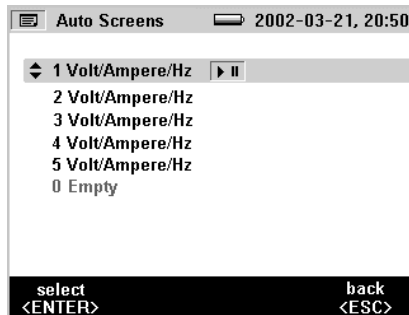
- View Auto Screenshots

With this menu item, you can view the screenshots of a recording session, which have been automatically saved in the Save mode. 6 screenshots are available (01...06).

Select one of the pictures with the cursor key and press ENTER to view it.

Note: Saved Auto Screenshots always show the currently displayed parameters.

Example: If you selected phase L2 in the Volt/Ampere/Hertz function and the recording reaches the margin of the picture, a screenshot of the current picture, i.e., phase L2, is saved.

- Display Contrast

Select the display contrast optimal for you with \uparrow \downarrow .

- Instrument Set-Up

In this menu option you can make adjustments in the submenu for:

- Current probes
- Voltage probes
- Version number
- Background lighting

These are described individually in the following:

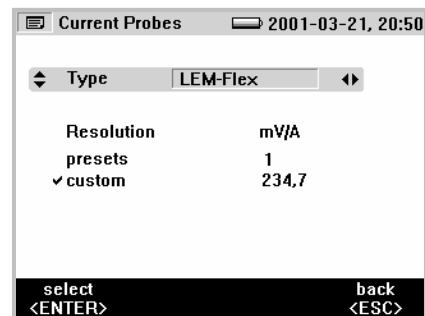
Current Probes

If you do not use standard accessories, which are automatically detected during start-up, you can make the necessary adjustments here. Select one of the given transducer types with "Type". Enter the transducer factor, through selection of a given value or by input of a customized value, e.g.: for a current probe displaying 0.5V per 5A this equals 100mV/1A.

Therefore, 100 should be entered.

Note: We recommend the use of standard accessories since it makes the operation easier and clearer.

Voltage Transformers

If you use voltage transformers, select transducer factors with ENTER. Press the \leftrightarrow key and enter any transformer factor with \updownarrow .
For transducer factor details see information on the voltage transformer.

Backlight

Here, you have the possibility to select whether the background lighting is to deactivate itself automatically after 30 seconds or whether you want to always deactivate it manually after switching it on with the  key.

Note:

If the battery is in use, use the background lighting only if necessary. This will ensure a longer battery life time.

Version & Calibration

This menu serves for your information. No adjustments can be made. The displayed data give information of type and version of the device.

- Power Network

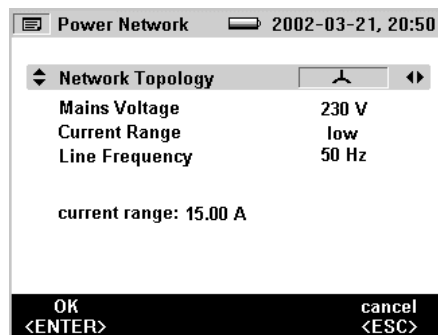

Select the used power network topology (Y or Δ) here. Likewise you can determine the nominal phase voltage of the power network, its nominal frequency and the current range.

- Date & Time

Here you can enter the current date and the current time.

- Language

Here you can select the language with which you want to operate.

3. Measuring Functions

3.1 Overview

Now we will give you a short overview of the different measuring procedures for the exact analysis of the power system, which is to be examined.

Volts / Amps / Hertz

This function displays the voltage and current values at the same time, as well as their frequency and the neutral-conductor current. You can also use this measuring function to get an overview of these values, before you analyse the signal in detail by means of the remaining functions.

Waveforms

This measuring function shows the voltages, currents and the φ angle in "oscilloscope representation" as well as their instantaneous values at the cursor position. With this function you get a clear representation of current and voltage waveforms and their distortions.

Harmonics

Harmonics are sinusoidal voltages with a frequency, which corresponds to an integer multiple of the fundamental of the mains voltage. Every signal can be split into an infinite number of sine waves of different frequency and amplitude. The contribution of each of these individual sine waves is represented in a bar chart up to the 40th harmonic. The smaller the harmonics are (starting from the 2nd harmonic, the 1st is the fundamental) the better is the power network quality.

Power

This function indicates the values of the transferred power. At the same time you can measure active power, reactive power, apparent power, distortion power and the appropriate power factor. You can also view the active and reactive power energy.

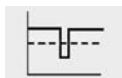

Events

Events are voltage dips, swells and interruptions. This measuring mode automatically records all events for later evaluation. The threshold values for starting the recording are freely configurable in the menu.

3.2 Connecting the Analyser

When connecting current circuits, the corresponding measuring lines must first be connected to the base unit and then to the current sensor to prevent the risk of electric shock in case of false connection.

Use the original cables only for connecting the current probes and the voltages to the analyser. If these are damaged do not use them anymore. Make sure that all plugs are connected correctly and locked, in order to prevent contact with live sections.

Measurement in a Single-Phase Power Network

In order to measure in a single-phase power network, connect your device to the power network according to the following figure .

In order to analyse the measured values correctly, you must pay attention to the colour code or the labels of the measuring wires:

Voltage:

Mains line	Test leads
L	L1
L	L2
L	L3
N	N

Current:

Mains line	Test leads
L1	L1
not connected	L2
not connected	L3
not connected	N

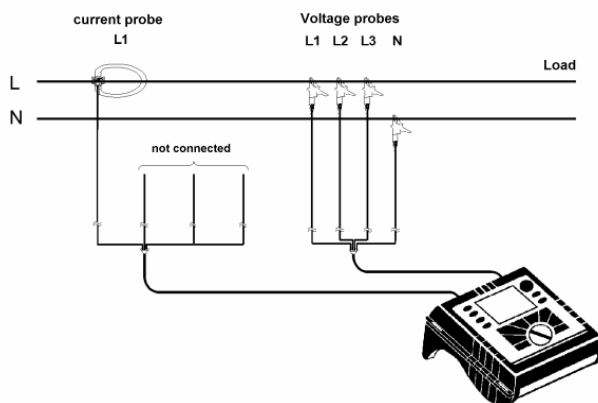

Measurement in a Three-Phase Power Network

In order to measure all phases in the three-phase power network with the Analyser you attach your device to the measuring power network according to the following figure. If you switch the network topology to Δ under supply networks in the menu, the measurement is conducted in an Aron measuring circuit (2-wattmeter method).

See section **3.4 Power** for further details.

The following wiring diagram applies to star connections and delta connections. In order to analyse the measured values correctly, you must pay attention to the colour code or the labels on the measuring wires:

Voltage:

Mains line	Test leads
L1	L1
L2	L2
L3	L3
N	N

Current:

Mains line	Test leads
L1	L1
L2	L2
L3	L3
N	N

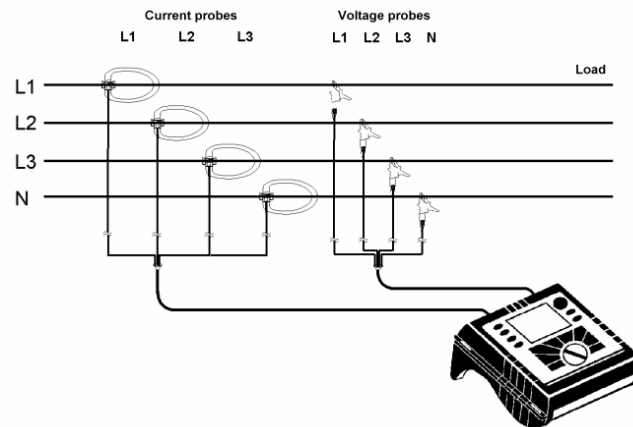

3.3 Volts / Amps / Hertz

Select  with the rotary switch.

In this mode you can measure values for each phase (L1, L2, L3) of

- Voltage (U)
- Current (I)
- Frequency (F)
- Neutral-conductor current (In)

You can determine and store the values. It is also possible to record the values with the recorder function.

Measurement or calculation of the neutral-conductor current is optional.

Recording

In Record mode, the following values are recorded for every phase (L1, L2, L3)

- Voltage (U) and
- Current (I) and the value of the
- Frequency (F)

These values can be analysed reported and exported with the PQLogView software.

Measurement

If you select this measuring mode you will see the following display:

▶ II Volt/Ampere/Hz		← 2002-10-21, 06:35	
↕ L123	In	0.5 A	49.99 Hz
	V rms	A rms	
L1	231.3	19.5	
L2	231.2	20.2	
L3	231.4	20.1	

⇕ Use this switch to get the following values

- minimum of values
- maximum of values and
- frequency or neutral-conductor current

⇔

With <Hold/Run> the actual values “freeze” and the measurement is stopped or started again.

Save:

With <Save/Enter> you will get a screenshot and thus store the actual picture of the display in the memory location subsequently shown.

Recorder Function:

With <Record/Measure> you can start the recorder function or you can get back into the measuring mode. Before the start, the maximum recording time is indicated and you can change this value with <Esc> followed by entering using the <Cursor> key.

Changes in the averaging time, cause corresponding changes in the recording time of the measurement (double averaging time = double recording time).

When the recorder graphics reach the screen margin during recording, a picture of this screen is saved.

The display is then deleted and the recording is continued. Up to 6 auto screens are saved in the course of a recording. The saved screenshots can be retrieved via the "View Auto Screenshots" menu.

Note:

Do not forget to operate the device with the DC adapter during recording in order to prevent shutdown caused by low battery.

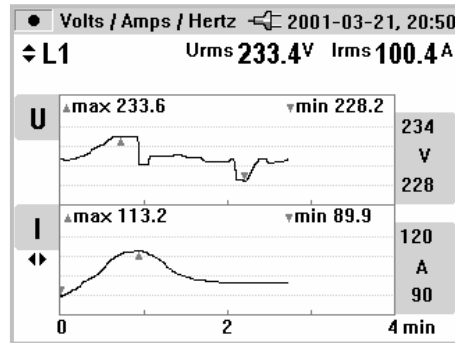

- ⇕ Select between the individual phases
- ⇔ Select between the two representation modes:
 - U and I (see fig.)
 - U and F
 - U and In

Analysing the measured values of the recorder function:

Use of the key <cursor>. When you invoke the cursors you can probe the graphs and display the associated values. With '⇕' you can select the individual phases again.

Note:

The Cursor functions are only available in the "Hold" mode.

3.4 Power

Select **W** with the rotary switch.

In this measuring mode you can get the following values for each phase (L1, L2, L3):

- Power (P) in *W* (for each phase and its sum P_{tot})
- Reactive power (Q) in *var*
- Apparent power (S) in *VA*
- Distortion power (D) in *VA*
- Power factor (PF)
- $\cos\varphi$
- Active energy (EP) in kWh
- Reactive energy (EQ) in kvarh

Measurement:

You can determine the instantaneous values and store them. Further it is also possible to record the values with the recorder function.

If you select this measurement mode you will get the following display:

Power			
L 123		Ptot 0.171 kW	49.78 Hz
	kW	kVA	PF
L1	0.305	0.476	0.642
L2	-0.399	0.503	-0.791
L3	0.265	0.379	0.700

↑ Switch between the individual phases (detailed view: min- max- values and distorted power)

↔ Switch between the representation modes:
 - P, S and PF
 - P, S and Q
 - P, S and D
 - P, S and EP
 - P, S and EQ
 - P, S and $\cos\varphi$

This function is also active in the detail view of the individual phases.

Capacitor or inductance symbols issue information about capacitive or inductive reactive power.

With <Hold/Run> the values displayed at the moment “freeze” and the measurement is stopped or started again.

Note: In the individual representation of L1 or L2 or L3, the active and reactive energy cannot be selected.

Δ - Topology:

By switching the network topology from star to delta, the voltages and currents I_{L1} , I_{L3} , I_{L2} are calculated, measured and displayed.

When calculating the power, selecting the delta connection will use the Aron measuring circuit for the calculation.

The neutral conductor may be connected, however, it does not influence the measurement even in open state. If no neutral conductor is connected, a virtual star point is formed via symmetrization resistors.

In the Aron circuit, phase L2 becomes the return line for L1 and L3 causing the current I_{L2} to be obtained as the sum of the two negative currents I_{L1} I_{L3} .

$$i_2(t) = -[i_1(t) + i_3(t)]$$

In general, the instantaneous total power is:

$$\rightarrow P_{tot}(t) = u_1(t) i_1(t) + u_2(t) i_2(t) + u_3(t) i_3(t)$$

$$\rightarrow P_{tot}(t) = u_1(t) i_1(t) - u_2 [i_1(t) + i_3(t)] + u_3(t) i_3(t) = \\ = [u_1(t) - u_2(t)] i_1(t) + [u_3(t) - u_2(t)] i_3(t)$$

However, since the voltages between the lines of a poly-phase are measured in the delta connection, the following formula results for the total power:

$$P_{tot}(t) = u_{12}(t) i_1(t) + u_{32}(t) i_3(t)$$

Integration via a period results in:

$$P_{tot} = U_{12} I_1 \cos(U_{12}, I_1) + U_{32} I_3 \cos(U_{32}, I_3)$$

Therefore, the total power corresponds to the total power of the star connection. For control purposes, it can be derived from the sum of the powers P_{12} and P_{31} .

Since I_{L2} is only calculated as an auxiliary value and is not measured, P_{23} must be set to zero (as per definition), because it does not exist in the Aron circuit.

The power factor PF has no physical meaning in the Aron circuit, because one would compare the current to the voltage between the lines of a poly-phase system. Reactive and apparent power should be understood as pure computing values and have no physical meaning.

The exact formulae for calculating the active power are given in the section Formulae.

Save:

With <Save/Enter> you will get a screenshot and thus store the actual display in the memory location shown subsequently.

Recorder Function:

With <Record/Measure> you can start the recorder function or you can get back into the measuring mode. Before the start, maximum recording time is indicated and you can change this value with <cursor>.

Changes in the averaging time, cause corresponding changes in the recording time of the measurement (double averaging time = double recording time).

When the recorder graphics reach the screen margin during recording, a picture of this screen is saved.

The display is then deleted and the recording is continued. Up to 6 auto screens are saved in the course of a recording. The saved screenshots can be retrieved via the "View Auto Screenshots" menu.

Note:

Do not forget to operate the device with the DC adapter during recording in order to prevent shutdown caused by low battery.

Active and reactive energy are not shown in the recorder function.

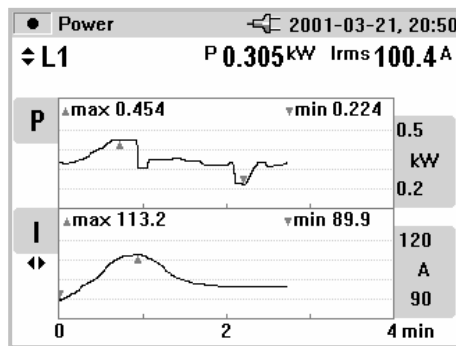

- ⇕ Switch between the individual phases
- ⇔ Switch between the representation modes:
 - P and Q
 - P and S
 - P and PF
 - P and $\cos\varphi$
 - P and D

Analysing the measured values of the recorder function:

Use of the key <cursor>. When you invoke the cursors you can probe the graphs and display the associated values. With '⇕' you can select the individual phases again.

Recording

In Record mode, the following values are recorded for every phase (L1, L2, L3)

- Active power (P)
- Apparent power (S)
- Reactive power (Q)
- Power factor (PF)
- Cosine ($\cos\varphi$)
- Power of distortion (D)

These values can be analysed reported and exported with the PQLogView software.

Note:

The cursor functions are only available in the "Hold" mode.

3.5 Events

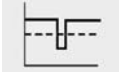
Select  with the rotary switch.

This measuring mode records the voltage of every phase (L₁, L₂, L₃) in case of voltage dips, swells or interruptions (recorder function).

Measurement:

This function exclusively works with the recorder function.

Before you start the measurement, select the desired threshold value with <Menu/Esc> (under recording adjustments). After the measurement has started the following message appears on the display.

. . . waiting for events

The device is now in the trigger mode. If an event on one of the phases occurs, the recording is started automatically and lasts for 4 minutes. The MIN and MAX values of the half-cycle effective values are shown as waves. The screenshots recorded by this method are saved as individual pictures and can be viewed later, or the data can be displayed with the PQLogView software. A total of 999 events can be recorded. In the LC display the phase and the number of recordings are displayed.

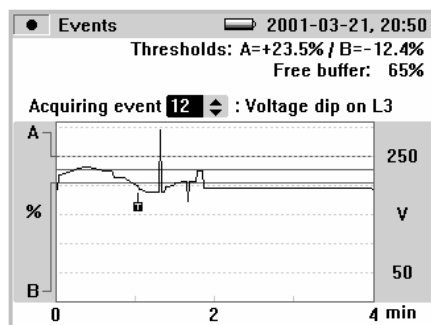

Switch between the individual events (if there is more than one)

This is also possible if the recording has been stopped and you want to evaluate the stored events.

With <Hold/Run> you can stop/start the measurement or you can also start a new measurement.

Save:

With <Save/Enter> you will get a screenshot and thus store the actual display in the memory location shown subsequently.

Recording:

Events recordings may be downloaded with the PQLogView software.

The PQLogView software presents the event data in a variety of formats:

- graphs similar to those displayed on the instrument
- statistical format with number of events, range of duration and range of voltage
- spreadsheet format with date/time stamp, event type and duration

3.6 Harmonics

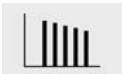
Select  with the rotary switch.

In this measuring mode you can determine the Harmonics H1 to H40 for all phases (L1, L2, L3) of:

- Voltage (U)
- Current (I)

Measurement

When selecting this measuring mode with the rotary switch the harmonics are immediately and clearly represented on the LC display as follows.

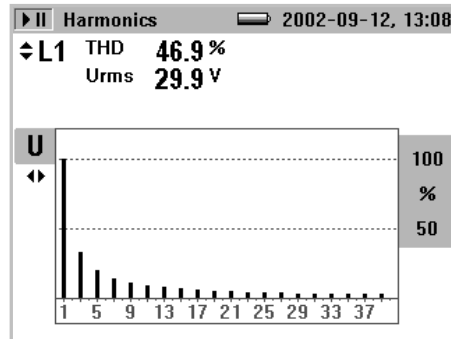

⇕ Switch between the individual phases

⇔ Switch between U and I

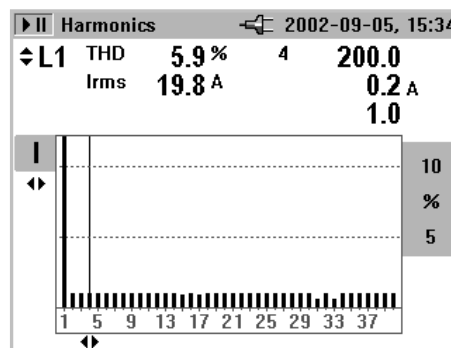

With <Hold/Run> the values displayed at the moment “freeze” and the measurement is stopped or started again. By pressing the <cursor> key, you will go into cursor mode, where you can read additional values of the individual harmonics. With ‘⇕’ you can select the individual harmonics. Once the cursor mode is activated, the scale can be changed with the ‘⇔’ from 100%-50% to 50%-25% or 10%-5%.

Recorder function:

<Record/Measure> starts the recorder function or goes from the recorder function back to the measurement mode, respectively.

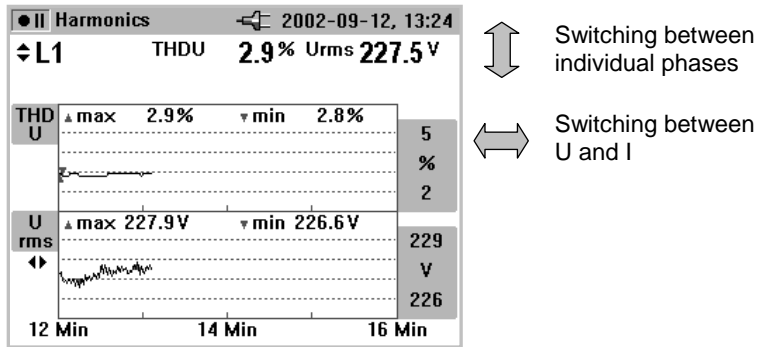

When the recorder graphics reach the screenmargin during recording, a picture of this screen is saved.

The display is then deleted and the recording is continued. Up to 6 auto screens are saved in the course of a recording. The saved screenshots can be retrieved via the "View Auto Screenshots" menu.

You can exit a measurement with HOLD, however, the measurement cannot be continued afterwards in order to evaluate the measurement values of the recorder function:

Use the <Cursor> key. Using the cursors keys, select the respective time and read the corresponding measurement value. Repeated pressing of the cursor keys sets a reference cursor.

Recording:

In Record mode, the following values are recorded for every phase (L1, L2, L3)

- Voltages (U) and
- Currents (I)
- THD U
- THD I
- Values of uneven harmonics from 1-25 for U and I
- Frequency

These values can be analysed reported and exported with the PQLogView software.

Save:

With <Save/Enter> you will get a screenshot and thus store the actual display in the memory location shown subsequently.

3.7 Waveforms

Select  with the rotary switch.

In this measuring mode you get an overview of the waveforms of

- Voltage (U)
- Current (I)
- Angle (φ)

for all three phases (L1, L2, L3).

Measurement

If you select the measuring mode with the rotary switch the following figure appears on the display. The three phase voltages and current values are plotted for the time of one period.

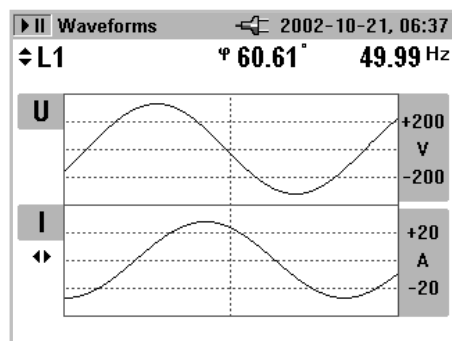

Switch between the individual phases or total view of all phases (as shown in figure)



While viewing the individual phases, the cursor can be shifted and the value at this location is displayed. In the individual view, the φ angle is also shown.

With <Hold/Run> the momentary values “freeze” and the measurement is stopped or started again.

Save:

With <Save/Enter> you will get a screenshot and thus store the actual display in the memory location shown subsequently.

Note:

In this mode the recorder function is not available.

The angle (φ) describes the phase shift between first harmonic active power and first harmonic reactive power. See formula in the formula section for more details.

4. Analyst 3P Software

Automated Download, Analysis and Reporting in one simple to use package.

4.1 Installing Analyst 3P Software

Insert the supplied CD-Rom, the main menu starts automatically (if it doesn't double-click on "setup.exe" and execute the program). Please follow the instructions appearing on the screen (menu):

PQLog View is a powerful application designed to help the user get the most from the Analyst 3P Power Quality Monitor.

4.2 Starting PQLog View

Click the Start button

From the start menu, point to programs, point to PQLog, then click on PQLog View.

Your screen will look like this:

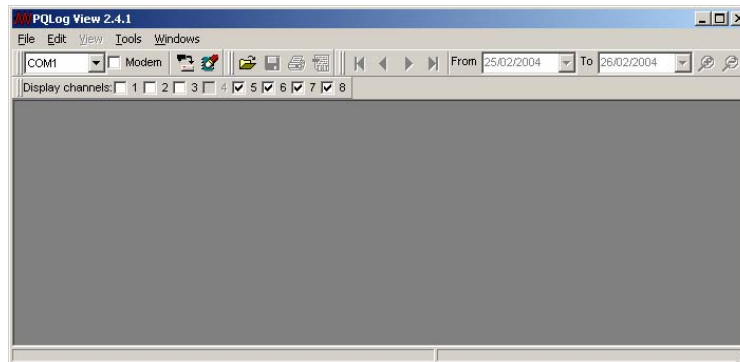

Fig. 1: PQLog View Screen

PQLog View incorporates several toolbars which provide quick access to commonly used functions. These functions are also accessible from the Menu Bar. All toolbars can be re-arranged by dragging them, or make them 'float' over the application. It is also possible to hide them by clicking the 'x' button when 'floating'.

The "Comms toolbar" comprises of 4 items: A serial port selector. To choose which port is used for communication with Analyst.

4.3 Using PQLogView

The supplied CD contains a presentation explaining the operation of the software, this presentation can be run directly from the item PQLogView Demonstration from the menu.

- The Download data button. A connection will be established with VLog, and all VLog recordings will be downloaded.
- The “Main Toolbar” also comprises of 4 items, but only 1 is active at start-up:
- Open data from File: To retrieve previously saved data files from the PC hard drive.
- The other 3 buttons are active when PQLog View has data stored in memory:
- Save data to File.
- Print Current Screen.
- Print report. This produces a printed report of the information on screen. It is possible to adjust the report parameters to avoid the printing of data not required and the generation of large reports.

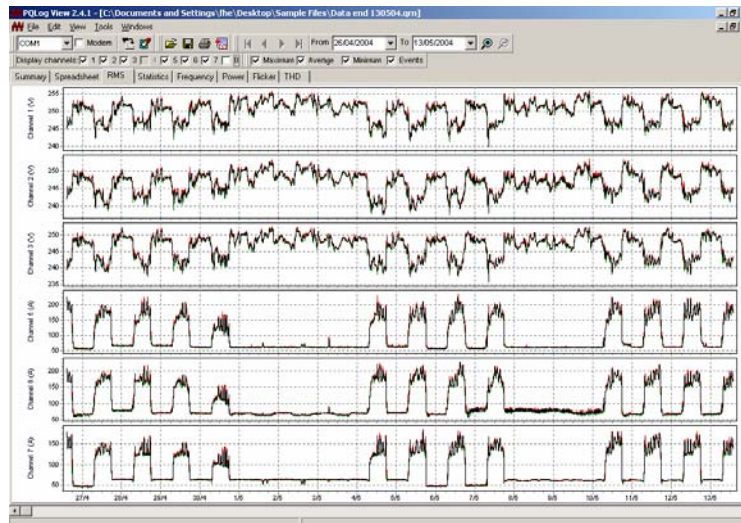

Fig. 2: PQLogView Displaying three phases of voltage and current downloaded from Analyst 3P

In PQLog View, every file has its own window within the main one. This allows files to be open simultaneously for comparison. Each of these windows has tab markers, which are used to select different viewing modes of the recorded data.

4.4 Recording measurement data with ANALYST 3P

This section describes the recording with 'Record' using a PQ measurement. However, this is only an example, which can be run analogous to every Record measurement.

The export of events is an exception, which is described separately under 4.3.

- Connect **ANALYST 3P** to the lines at the measurement location; set up for power measurement for example.
- Start the measurement by pressing "Record".
- In the W function, **ANALYST 3P** can record up to 1440 intervals based on the preset interval time. The process can be cancelled by pressing "Record" at any time.

Maximum possible measuring periods:

Measurement Function	Average Interval	Recording Time
V/A/Hz (including harmonics)	1s	24min
	2s	48min
	5s	2h
	10s	4h
	30s	12h
	60s	1d
	300s	5d
	600s	10d
	900s	15d
	10000s	166d 16h
W	1s	24min
	2s	48min
	5s	2h
	10s	4h
	30s	12h
	60s	1d
	300s	5d
	600s	10d
	900s	15d
	10000s	166d 16h

ANALYST 3P records the following parameters for each interval

Measurement function	Saved parameters
Volts/Amps/Hertz	
	Voltages UL1, UL2, UL3, AVG, MIN, MAX rms values
	Currents I1, I2, I3, AVG, MIN, MAX rms values
	Frequency, AVG, MIN, MAX values
W - Power	
	Currents I1, I2, I3, In AVG, MIN, MAX rms values
	Real powers P1, P2, P3, AVG, MIN, MAX values
	Voltages UL1, UL2, UL3, AVG, MIN, MAX rms values
	Apparent powers S1, S2, S3, AVG, MIN, MAX values
	Reactive powers Q1, Q2, Q3, AVG, MIN, MAX values
	Distortion powers D1, D2, D3, AVG, MIN, MAX values
	Frequency, AVG, MIN, MAX values
	Cos ϕ L1, L2, L3
	Power factors PF1, PF2, PF3, AVG, MIN, MAX values
	Reactive energy EQ1, EQ2, EQ3 Averages only
	Real energy EP1, EP2, EP3 Averages only
Events	
	Voltages UL1, UL2, UL3, MIN, MAX of 10-ms RMS values
	Number of events per phase

Harmonics	
	Voltages UL1, UL2, UL3, AVG, MIN, MAX rms values
	Currents I1, I2, I3, In AVG, MIN, MAX rms values
	THD I L1, L2, L3, In, AVG, MIN, MAX rms values
	THD U L1, L2, L3, AVG, MIN, MAX rms values
	Values of uneven harmonics from the 1st -25th order for U1, U2, U3, I1, I2, I3 ,In, AVG, MIN, MAX rms values
	Frequency, AVG, MIN, MAX values

5. Specific Data of the Analyser

5.1 Power Supply and Replacing the Battery Pack

Power-line or Battery Mode

Your Power Analyser can be operated with the provided charging adapter or with the built in battery.

If you operate your device with the charging adapter, the battery is charged automatically. On the LC display the symbol for the operating mode is displayed accordingly (see Chapter 2.2).

If the battery is completely discharged, it takes about 4 hours to charge it completely. It is impossible to overcharge the battery as the analyser has an automatic load regulation.

When "LO-BAT" is indicated, replace the batteries or recharge the accumulator.

Replacing the accumulator pack

If the accumulator capacity is noticeably low (see technical specification), then the accumulator pack has to be replaced. Please consider the following steps, which are described in the following figures:

1. Turn off the device
2. **Disconnect all measuring leads**
3. Open the battery compartment (two cross-notched screws)
4. Unplug and replace the battery pack. Close the battery compartment again.

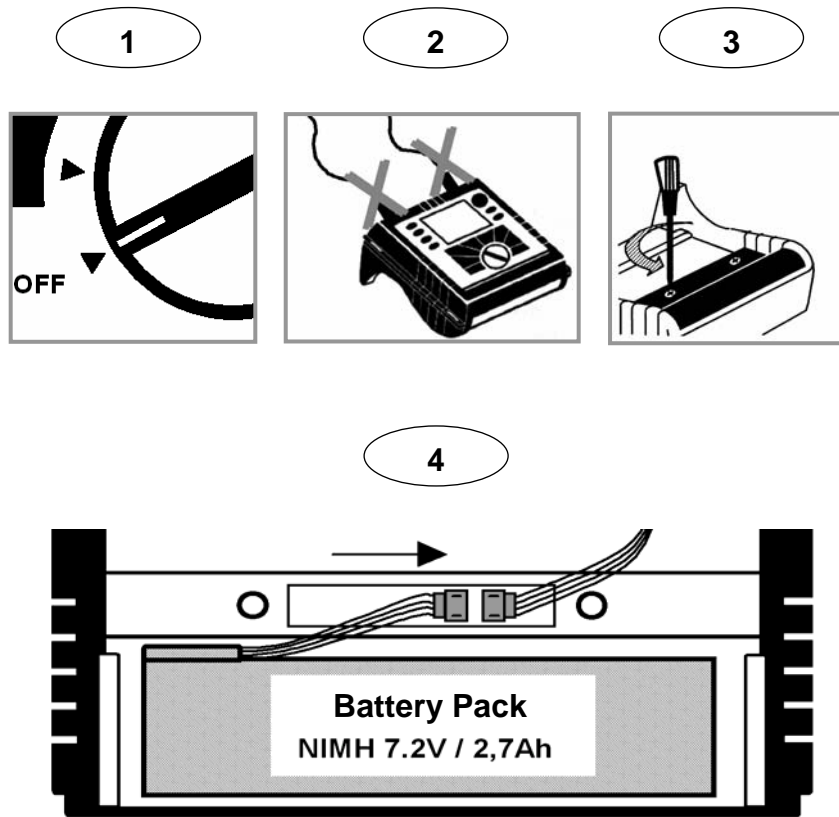

Note:

If you replace the battery please use original spare parts only – see section “Standard and Optional Accessories”.

5.2 Maintenance and Warranty

Maintenance

If the Analyser is used appropriately it does not require special maintenance or repair. If the device gets dirty wipe it off carefully with a damp cloth (without cleaning agents). Maintenance work may be executed only by trained and qualified personnel. This work may only be done at a company related workshop within the guarantee period.

Calibration

As an additional service we offer the regular examination and calibration of your device. On request we also issue company-owned test certificates (traceable to national standards) or test certificates of the UK calibration service (UKAS).

Storage

If the device is stored for longer time or is not in use for longer time, you should charge the battery at least once in six months.

Warranty

2 Years:

- Warranty on the accuracy of the device
- Free repair, if the device shows a functional fault although it is used appropriately.

This warranty does not apply, if damages are due to false handling of the device or to excessive overload.

Note:

This manual does not contain all the detail information concerning your Analyser. In order to keep the manual short and clear, not every case of application, operation or maintenance imaginable could be included.

5.3 Calculation of the Measured Variables

The following formulas are the basics of the measuring values:

Voltage and current measurement

$$U_{RMS} = \sqrt{\frac{1}{T} \int u^2 dt} \quad \text{rms value of voltages}$$

$$I_{RMS} = \sqrt{\frac{1}{T} \int i^2 dt} \quad \text{rms value of currents}$$

$$I_N = I_1 + I_2 + I_3 \quad \text{rms value of neutral-conductor current}$$

* Is calculated when not measured, i.e., no 4-phase LEM-flex is connected.

Wave form

The angle given in the waveform function is based on the following formula.

$$\varphi = \arctan \left(\frac{P_1}{\sqrt{P_1^2 + Q_1^2}} \right) \quad \begin{array}{l} \text{Angle between} \\ Q_1 \dots \text{reactive power of first harmonic} \\ P_1 \dots \text{active power of first harmonic} \end{array}$$

Power measurements

$P = \sum_{k=1}^{40} U_k \times I_k \times \cos(\varphi_k)$	active power (200ms average values) U _k , I _k , φ _k .. values of harmonics
$P_M = \frac{1}{M} \sum_{i=1}^M P_i$	active power over average interval P _i ...single 200ms values M...number of values
$P_{tot} = P_1 + P_2 + P_3$	total active power
$P_{tot} = P_1 + P_2 + P_3$	total active power Aron
$Q = \sum_{k=1}^{40} U_k \times I_k \times \sin(\varphi_k)$	reactive power (200ms average values) U _k , I _k , φ _k .. values of harmonics
$Q = \frac{1}{M} \sum_{i=1}^M Q_i$	reactive power over average time
$S = U \times I$	apparent power
$PF = \lambda = \frac{P}{S}$	power factor
$D = \sqrt{S^2 - P^2 - Q^2}$	distortion power
$\cos \varphi = \frac{P_1}{\sqrt{P_1^2 + Q_1^2}}$	cosine cosφ

Note:

The distortion power is > zero if the waveform of current is different from the voltage waveform.

Total harmonic distortion

$THD = \frac{\sqrt{\sum_{h=2}^{40} (U_h)^2}}{U_1} \times 100\%$	Total Harmonic Distortion U ₁ . . . RMS of the fundamental U _h . . . RMS of the h-th harmonic
---	---

5.4 Technical Specification

General Information:

Display:	¼ VGA Graphic Colour transmissive display 320 x 240 Pixel with additional background lighting and adjustable contrast, text and graphics in colour.
Quality:	Developed, designed and manufactured according to DIN ISO 9001
Memory:	2 MB Flash memory, from this 1.5 MB for measuring data;
Interface:	RS 232 SUB-D socket; 115,2 kBaud, 8 data bits, no parity, 1 stop bit, firmware updates are possible with the RS 232 interface (9-pole extension cable)
Sample rate:	10.24 kHz
Mains frequency:	50 Hz or 60 Hz with automatic synchronisation
Temperature ranges:	
Working temperature range:	-10° C...+50° C
Storage temperature range:	-20° C...+60° C
Operating temperature range:	0° C...+40° C
Reference temperature range:	+23° C ± 2K
Temperature coefficient:	± 0.1 % of the measured value per K.
Intrinsic error:	Refers to reference temperature, max. deviation is guaranteed for 2 years.
Operating error:	Refers to operating temperature range, max. deviation is guaranteed for 2 years.
Climatic class:	C1 (IEC 654-1) -5°C...+45°C, 5%...95% RH, no dew
Housing:	Cycloy shock and scratch proof thermoplast V0-type (not inflammable) with rubber protection holster
EMC	
Emission:	IEC/EN 61326-1:1997 class B
Immission:	IEC/EN 61326-1:1997 IEC/EN 61326-1, amendment 1: 1998
Power supply :	NiMH battery-pack, with mains adapter (15 V / 0.8 A)
Operation time with battery:	Typical > 24h without back light > 12h with back light
Dimensions:	240 x 180 x 110 mm
Weight:	1.7 kg (incl. battery)

Safety:

Safety: IEC 61010-1 600V CAT III, double or enforced insulation, pollution degree 2

Protection: IP65; EN60529 (refers only to the main housing without the accumulator compartment)

Specifications:

Rms values are measured with a 20-ms resolution.

V-rms Υ measurement

Measuring range: 57 / 66 / 110 / 120 / 127 / 220 / 230 / 240 / 260 / 277 / 347 / 380 / 400 / 417 / 480 V AC

Intrinsic error : $\pm(0.2\%$ of m. v. + 5 digit)

Operating error : $\pm(0.5\%$ of m. v.+ 10 digit)

Resolution: 0.1 V

V-rms Δ measurement

Measuring range: 100 / 115 / 190 / 208 / 220 / 380 / 400 / 415 / 450 / 480 / 600 / 660 / 690 / 720 / 830 V AC

Intrinsic error : $\pm(0.2\%$ of m. v. + 5 digit)

Operating error : $\pm(0.5\%$ of m. v.+ 10 digit)

Resolution: 0.1 V

A-rms measurement

LEM-flex and current probes with voltage output are supported. All current probes must correspond to 600V / CAT III

LEM-flex I_N ranges: 15 / 150 / 3000 A rms (at sine)

Current clamp ranges: 50 / 500 mV AC

Resolution: 0.01 A

Ranges 150 / 3000 A and 50 / 500 mV

Intrinsic error : $\pm(0.5\%$ of m. v. + 10 digit)

Operating error : $\pm(1\%$ of m. v.+ 10 digit)

Range 15 A

Ranges 15 A and 5 mV

Intrinsic error : $\pm(0.5\%$ of m. v. + 20 digit)

Operating error : $\pm(1\%$ of m. v.+ 20 digit)

The errors of the current probes are not considered.

By using LEM-flex:

LEM-flex measuring error: $\pm(2\%$ of m. v. + 10 digit)

Position influence: $\pm(3\%$ of m. v. + 10 digit)

CF (typical): 2.83

Power measurement (P, Q, S, D)

Measuring range: see Vrms and Arms measurement

Power errors are calculated by adding the errors of voltage and current.

Additional error due to power factor PF:

Specified error x (1-IPFI)

Maximum Range with Voltage range 830V delta-connection and 3000A current range is 2.490MW

Intrinsic error: $\pm (0,7 \% \text{ of m.v.} + 15 \text{ dig})$
 Resolution: 1 kW
 Operating error: $\pm (1,5 \% \text{ of m.v.} + 20 \text{ dig})$

Typical Range with Voltage range 230V star-connection and 150A current range is 34,50kW

Intrinsic error: $\pm (0,7 \% \text{ of m.v.} + 15 \text{ dig})$
 Resolution: 1W...10W
 Operating error: $\pm (1,5 \% \text{ of m.v.} + 20 \text{ dig})$

The errors of the current sensors themselves have not been considered.

PF Power Factor

Range: 0,000 to 1,000
 Resolution: 0,001
 Accuracy: $\pm 1\%$ of full scale

Frequency measurement

Measuring range: 46 Hz – 54 Hz and 56 Hz – 64 Hz
 Intrinsic error : $\pm(0.2\% \text{ of m. v.} + 5 \text{ digit})$
 Operating error : $\pm(0.5\% \text{ of m. v.} + 10 \text{ digit})$
 Resolution: 0.01 Hz

Harmonics

Measuring range: 1...40th harmonic (< 50% von U_m)
 Accuracy:
 $U_m, I_m, THDU, THDI$: according IEC 1000-4-7, class B
 $U_m, I_m, THDU, THDI$: according IEC 1000-4-7, class B
 $U_m \geq 3\% U_N$ 5% U_m
 $U_m < 3\% U_N$ 0.15% U_N
 $I_m \geq 10\% I_N$ 5% I_m
 $I_m < 10\% I_N$ 0,5% I_N
 THDU for THD <3%: < 0.15% at U_N
 for THD $\geq 3\%$: < 5% at U_N
 THDI for THD <10%: < 0.5 % at I_N
 for THD $\geq 10\%$: < 5% at I_N

Events

Detection of voltage dips, voltage swells and voltage interruptions with a 10-ms resolution. Due to storage reasons, the maximum number of event recordings is 999. Measuring error of the half-period sine wave of RMS:
 Intrinsic error : $\pm(1\% \text{ of m. v.} + 10 \text{ digit})$
 Operating error : $\pm(2\% \text{ of m. v.} + 10 \text{ digit})$
 Resolution: 0.1 V

Unbalance

rms errors see V-rms specification

Phase angle errors:

Intrinsic error : $\pm(0,5\%$ of m. v. + 5 digit)

Operating error : $\pm(1\%$ of m. v.+ 10 digit)

Resolution: 0.1 °

Note:

When using LEM-flexes please make sure to position the conductor opposite to the LEM-flex-lock (see right).

