

# SC-FI Series

*Frequency to Current Signal Conditioner*

**KEP**  
KESSLER-ELLIS PRODUCTS

**Description:**

The SC-FI is a two wire frequency to analog converter that converts a pulse rate input into a 4-20 mA output signal proportional to frequency or rate.

The input pulse rate is amplified and filtered by the input signal conditioning circuitry. Two forms of input signal conditioning are provided, one for magnetic pickups and the other being an isolated pulse input.

The amplified frequency signal is then converted to an analog signal using a precision frequency to analog converter.

The output stage derives its power from the output current loop. The output stage converts the input signal into the desired output range. Multi-turn potentiometers provide for the necessary trimming of span and zero.

**SPECIFICATIONS:**

**Operating Temperature**

32° F (0°C) to 158°F (70°C)

**High Level Pulse Input**

- Type: Opto-Isolated
- Logic 1: 4-30 VDC
- Logic 0: 0-1 VDC
- Frequency Range: 0-10 kHz
- Fault Protection: Reverse Polarity Protection  
Over Voltage Protection

- Isolation Voltage: 500 V
- Fast Transient Immunity: 500 V
- Maximum Rise Time: No Limit
- Maximum Fall Time: No Limit

**Magnetic Pickup Input**

- Differential Input
- Input Impedance: 10 kΩ
- Frequency Response: 0-3500 Hz
- Trigger Sensitivity: 30 mV p-p
- Over Voltage Protection: ± 30 VDC

**Frequency to Current Conversion**

- Range Selection: DIP Switch Selectable
- Available Ranges: 150 Hz, 300 Hz, 600 Hz, 1200 Hz,  
2500 Hz, 5000 Hz, 10,000 Hz
- Factory Default: 1000 Hz

**Simplified Block Diagram**

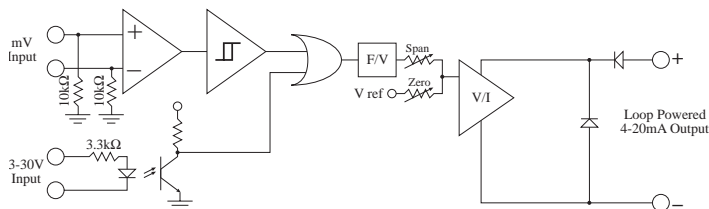

**Analog Output**

- Accuracy: ± 0.1% Span (@ 20° C)
- Output Type: Two Wire, Loop Powered
- Range: 4-20 mA (10 - 50 mA optional)
- Compliance Voltage: 10 to 40 VDC
- Loop Burden: < 10 VDC (less than 500 Ω)
- Trim Controls: Zero & Span, non-interacting
- Span (20 mA) Trim Range: 50% to 100% of full scale
- Linearity: < ±0.1% Span
- Output Voltage Effect: < ± 0.002% Span/Volt
- Temperature Effect: < 200 PPM/C°
- Reverse Polarity Protected
- Noise Content: < 0.2% Span
- Response Time: 0.1 second (1 sec. jumper selectable)
- Over-current Limiting: 35 mA
- Output Loop Indicator: LED illuminates when output loop is powered by proper polarity and blinks proportionally to the input frequency.

**Mounting Styles**

- DIN Rail Mount: Plastic enclosure with a snap fastener for fitting to DIN 46 277 and DIN EN 50 022 assembly rails.
- NEMA 4X: 4.92" x 4.92" NEMA 4X Enclosure for wall mounting.
- Explosion Proof: Aluminum enclosure for:  
Class I, Division 1, Groups B, C & D  
Class II, Division I, Groups E, F & G.

**Typical Wiring Hookup**

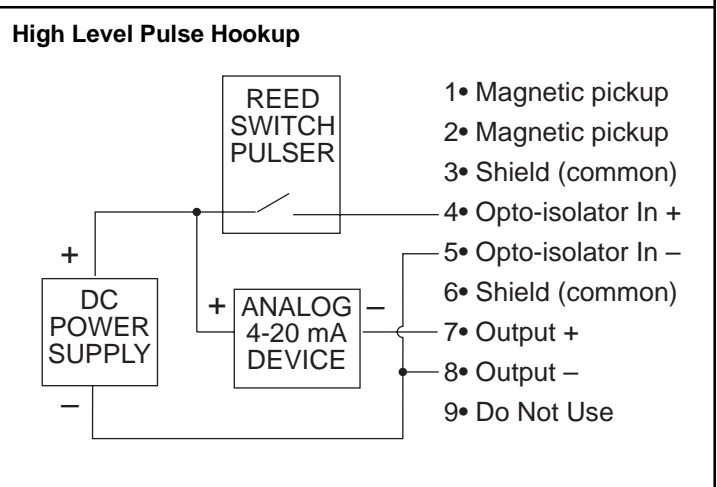
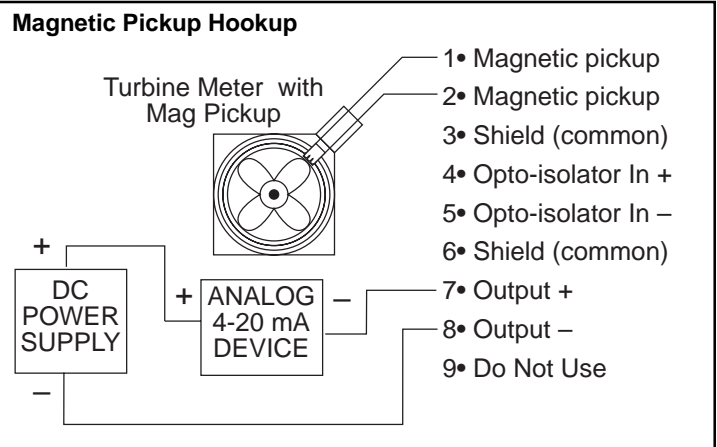

## INPUT & OUTPUT SETTINGS

**REMOVING THE CASE:**

The case must be removed to change switch settings. To remove the case proceed as follows:

Refer to FIGURE 1. Using finger tips, carefully pry the case away from the terminal blocks (as shown with dotted lines).

Pry far enough to release the restraining clips on both sides of the case.

Press up on terminal block with thumbs. The assembly will pop out allowing it to be removed from case.

**FIGURE 1:**

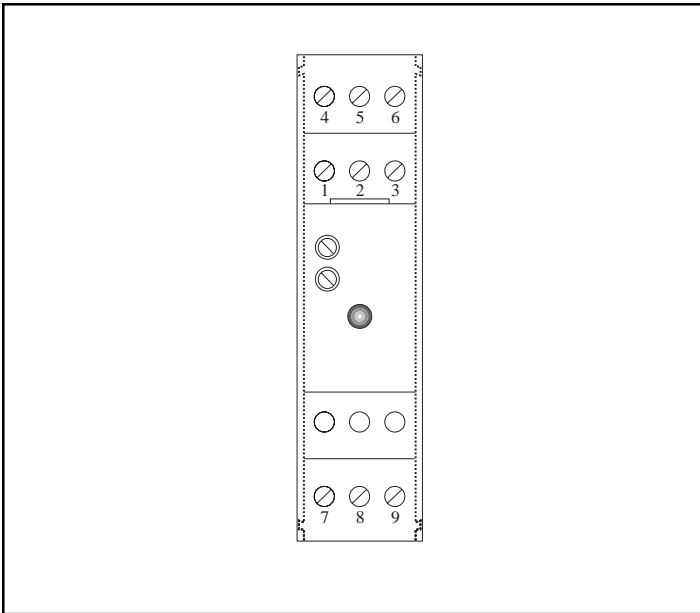

**INPUT FREQUENCY RANGE SETTINGS:**

The appropriate range is selected by turning "ON" the corresponding switch.

Range:	Switch # "ON"
0-150Hz	1
0-300Hz	2
0-600Hz	3
0-1200Hz	4*
0-2500Hz	5
0-5000Hz	6
0-10000Hz	7

\* Factory Default. The unit is setup at the factory for the range 0-1000Hz.

**OUTPUT ADJUSTMENTS:**

The unit has two potentiometers for adjustment. The upper potentiometer controls the 20mA setpoint and the lower potentiometer controls the 4mA setpoint (see Figure 2). The 4mA output range can be adjusted from 3mA to 5mA. The 20mA output range can be trimmed from 50% to 100% of the selected range. To adjust the output, initially turn the 20ma adjust 20 turns CW for starting position. Input 0 frequency and adjust the 4 mA pot. Connect your maximum frequency and adjust the 20 mA pot.

**FIGURE 2:**

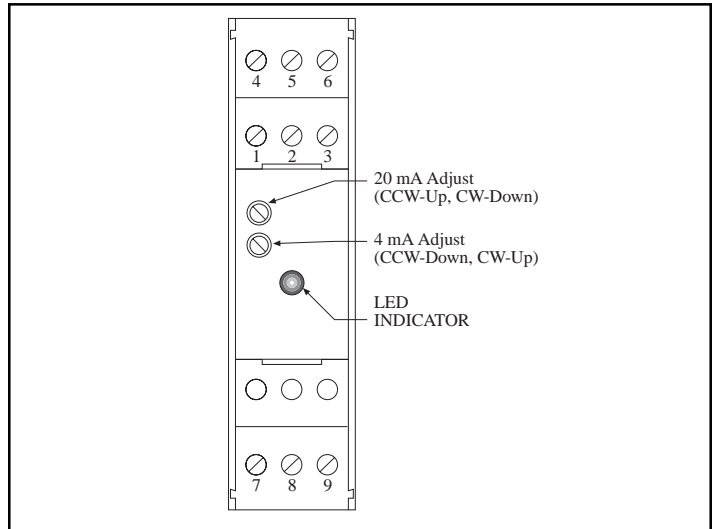

**RESPONSE TIME SETTING:**

Switch #8 controls the output response time.

Switch #8	Response Time
OFF	0.1 second
ON	1 second

Turn switch #8 ON to provide damping of the output resulting in a 1 second response time.

**LED INDICATOR:**

The SC-FI has a LED which indicates the status of the unit. The table below describes the 3 states for the LED.

LED STATUS:	MEANING:
OFF	The unit is off.
ON (constant)	The unit is loop powered.

**BLINKING** The unit is receiving an input frequency. The LED will blink at a rate proportional to the input frequency. (The LED may appear to be constant at high input frequencies)

# "L" Option SPECIFICATIONS

## Description:

The SC-FI with option "L" is a two wire frequency to analog converter that converts a pulse rate input into a 4-20 mA output signal proportional to frequency or rate.

The SC-FI with option "L" is intended for use with lower full scale input frequencies. Full scale frequencies of 15 Hz to 2000 Hz are possible. The unit includes both a contact closure input and an opto-isolated input. Output response time is selectable 1 or 10 seconds.

The amplified frequency signal is then converted to an analog signal using a precision frequency to analog converter.

The output stage derives it's power from the output current loop. The output stage converts the input signal into the desired output range. Multi-turn potentiometers provide for the necessary trimming of span and zero.

## SPECIFICATIONS:

### Operating Temperature

32° F (0°C) to 158°F (70°C)

### High Level Pulse Input

- Type: Opto-Isolated
- Logic 1: 4-30 VDC
- Logic 0: 0-1 VDC
- Frequency Range: 0-10 kHz
- Fault Protection: Reverse Polarity Protection  
Over Voltage Protection
- Isolation Voltage: 500 V
- Fast Transient Immunity: 500 V
- Maximum Rise Time: No Limit
- Maximum Fall Time: No Limit

### Contact Closure Input

- Sensor Compatibility- Requires an isolated, contact closure
- Maximum Contact Voltage- 5 V
- Maximum Contact Current- 0.12 mA
- Nominal Pullup Resistance - 47 Kohm to 5 Vdc
- Frequency Range - 0-100 Hz

### Frequency to Current Conversion

- Range Selection: DIP Switch Selectable
- Available Ranges: 30 Hz, 60 Hz, 120 Hz, 240 Hz,  
480 Hz, 960 Hz, 1920 Hz
- Factory Default: 100 Hz

### Simplified Block Diagram

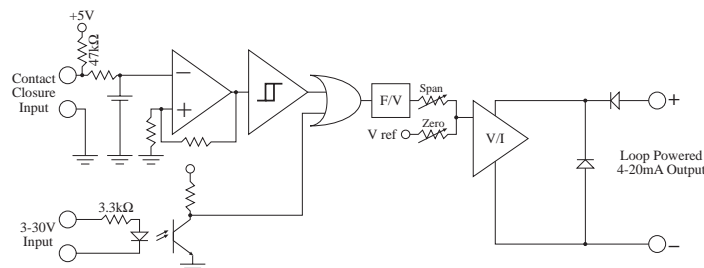

## Analog Output

- Accuracy:  $\pm 0.1\%$  Span (@ 20° C)
- Output Type: Two Wire, Loop Powered
- Range: 4-20 mA (10 - 50 mA optional)
- Compliance Voltage: 10 to 40 VDC
- Loop Burden: < 10 VDC (less than 500  $\Omega$ )
- Trim Controls: Zero & Span, non-interacting
- Span (20 mA) Trim Range: 50% to 100% of full scale
- Linearity: <  $\pm 0.1\%$  Span
- Output Voltage Effect: <  $\pm 0.002\%$  Span/Volt
- Temperature Effect: < 200 PPM/C°
- Reverse Polarity Protected
- Noise Content: < 0.2% Span
- Response Time: 1 second (10 sec. jumper selectable)
- Over-current Limiting: 35 mA
- Output Loop Indicator: LED illuminates when output loop is powered by proper polarity and blinks proportionally to the input frequency.

## Mounting Styles

- DIN Rail Mount: Plastic enclosure with a snap fastener for fitting to DIN 46 277 and DIN EN 50 022 assembly rails.
- NEMA 4X: 4.92" x 4.92" NEMA 4X Enclosure for wall mounting.
- Explosion Proof: Aluminum enclosure for:  
Class I, Division 1, Groups B, C & D  
Class II, Division I, Groups E, F & G.

## Typical Wiring Hookup (option "L")

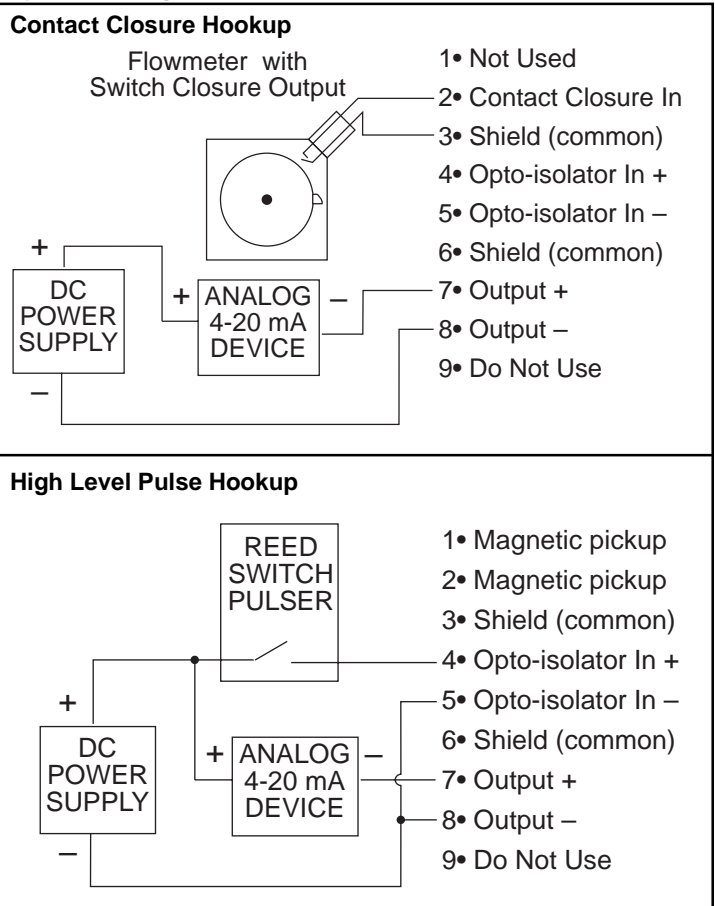

## "L" Option INPUT & OUTPUT SETTINGS

**REMOVING THE CASE:**

The case must be removed to change switch settings. To remove the case proceed as follows:

Refer to FIGURE 1. Using finger tips, carefully pry the case away from the terminal blocks (as shown with dotted lines).

Pry far enough to release the restraining clips on both sides of the case.

Press up on terminal block with thumbs. The assembly will pop out allowing it to be removed from case.

**FIGURE 1:**

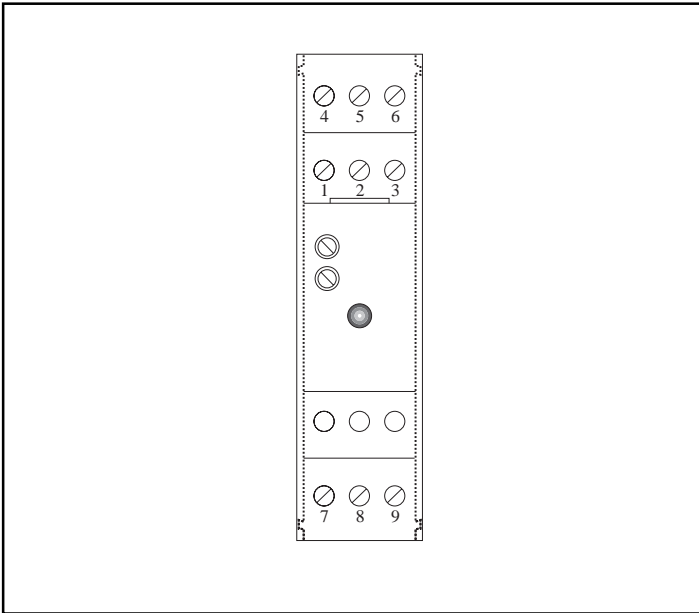

**OUTPUT ADJUSTMENTS:**

The unit has two potentiometers for adjustment. The upper potentiometer controls the 20mA setpoint and the lower potentiometer controls the 4mA setpoint (see Figure 2). The 4mA output range can be adjusted from 3mA to 5mA. The 20mA output range can be trimmed from 50% to 100% of the selected range. To adjust the output, initially turn the 20mA adjust 20 turns CW for starting position. Input 0 frequency and adjust the 4 mA pot. Connect your maximum frequency and adjust the 20 mA pot.

**FIGURE 2:**

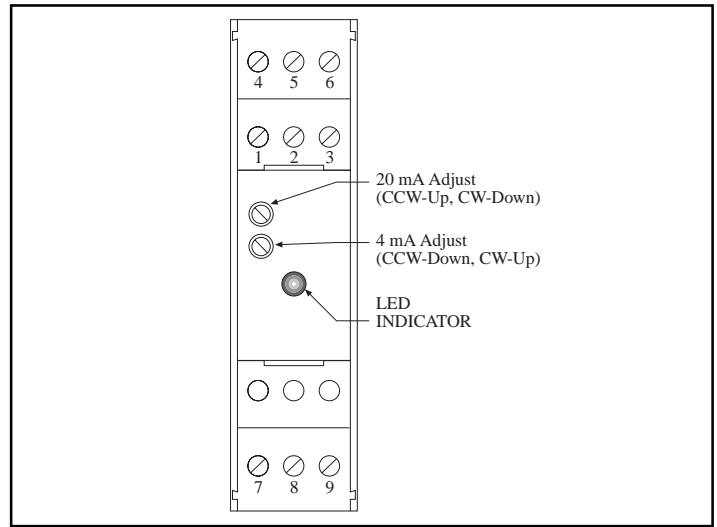

**RESPONSE TIME SETTING:**

Switch #8 controls the output response time.

<u>Switch #8</u>	<u>Response Time</u>
OFF	1 second
ON	10 second

Turn switch #8 ON to provide damping of the output resulting in a 10 second response time.

**INPUT FREQUENCY RANGE SETTINGS:**

The appropriate range is selected by turning "ON" the corresponding switch.

<u>Range:</u>	<u>Switch # "ON"</u>
0-30Hz	1
0-60Hz	2
0-120Hz	3*
0-240Hz	4
0-480Hz	5
0-960Hz	6
0-1920Hz	7

\* Factory Default. The unit is setup at the factory for the range 0-100Hz.

**LED INDICATOR:**

The MS660 has a LED which indicates the status of the unit. The table below describes the 3 states for the LED.

<u>LED STATUS:</u>	<u>MEANING:</u>
OFF	The unit is off.
ON (constant)	The unit is loop powered.

**BLINKING** The unit is receiving an input frequency. The LED will blink at a rate proportional to the input frequency. (The LED may appear to be constant at high input frequencies)

**Dimensions**

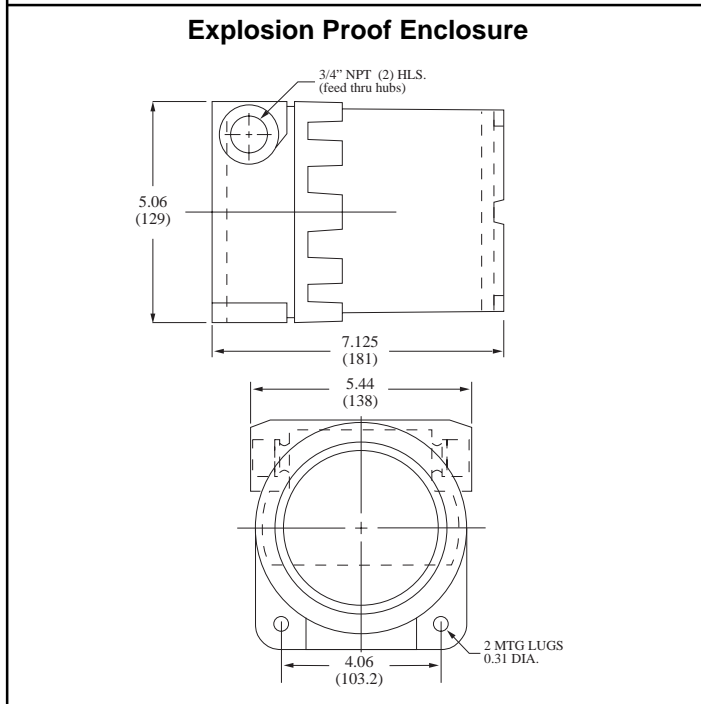
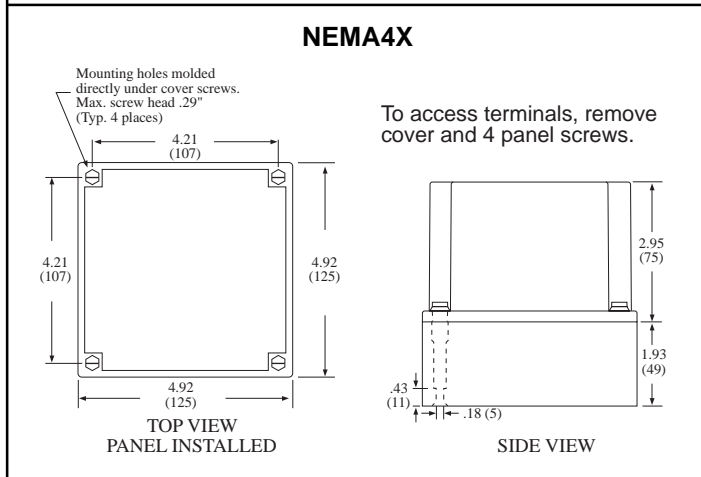
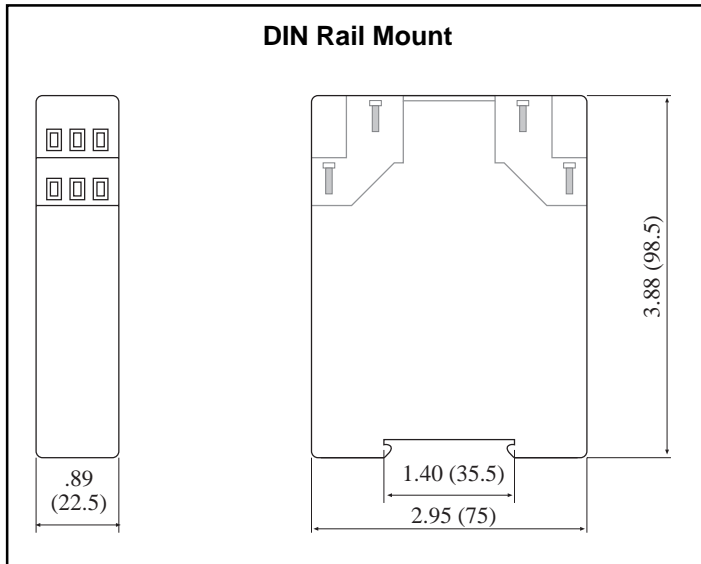

**WARRANTY**

This product is warranted against defects in materials and workmanship for a period of two (2) years from the date of shipment to Buyer.

The Warranty is limited to repair or replacement of the defective unit at the option of the manufacturer. This warranty is void if the product has been altered, misused, dismantled, or otherwise abused.

ALL OTHER WARRANTIES, EXPRESSED OR IMPLIED, ARE EXCLUDED, INCLUDING BUT NOT LIMITED TO THE IMPLIED WARRANTIES OF MERCHANTABILITY AND FITNESS FOR A PARTICULAR PURPOSE.

**Decoding Part Number**

<b>Example</b>	<b>SC-FI</b>	<b>D</b>	<b>ET</b>
<b>Series</b>	_____	_____	_____
FI= Frequency to Current			
<b>Mounting:</b>	_____	_____	_____
B= Nema 4X			
C= Explosion Proof			
D= DIN Rail			
<b>Options:</b>	_____	_____	_____
ET= Extended Temp (-20° to 85° C)			
L = Low Count Speed for Contact Closure Inputs			
50 = 10-50 mA output			

**Accessories:** (add to end of part number)  
DR-4= 4" DIN Rail