

MODELS

NRT

NC2

NR2

NRT SERIES

Ratemeter/Totalizer for NAMUR Sensors INSTALLATION & OPERATING INSTRUCTIONS

TABLE OF CONTENTS

SPECIFICATIONS.....	1
DECODING PART NUMBER	2
HOW TO MOUNT THE UNIT	3
WIRING	4
UP/DOWN CONTROL AND QUADRATURE INPUTS	4
WHAT CAN YOU VIEW.....	6
OUTPUT JUMPER SELECTIONS	6
MILLIVOLT INPUT OPTION JUMPER SELECTIONS	6
OPERATING FRONT PANEL.....	7
PROGRAMMING FLOW CHART	7
PROGRAM CODES & DESCRIPTIONS.....	8
TERMINATIONS.....	9
CALCULATING SCALE FACTORS.....	10
PROGRAMMING PROCEDURE.....	11
SETTING SCALING FACTORS	11
SETTING THE COUNTER.....	12
SETTING THE RATE	13
SETTING THE LOCK CODE & LOCKING THE UNIT.....	14
SETTING THE RELAYS & PRESETS.....	15
OUTPUT WIRING	16
ANALOG OUTPUT OPTION	17
RS232/RS422 SERIAL COMMUNICATIONS.....	18
TROUBLESHOOTING GUIDE	21

DESCRIPTION & SPECIFICATIONS

Application:

Any rate, total or blending application where 2 preset alarms and scaling are required for a NAMUR sensor.

Description:

The NAMUR R/T (NRT) is a 6 digit totalizer / ratemeter with two level, 5 digit preset alarm control of total or rate. Inputs A & B have separate scaling K-factors. The totalizer can be programmed for "A" subtract "B", "A" add "B" or A & B as separate totalizers, with display and control of the "net" total and rate of "A". The NAMUR R/T is also available in 2 other versions. NC2: a two preset totalizer with scaling, NR2: a high/low alarm ratemeter with scaling. If only one input is required, the unit will display the total and rate from that one channel. The NAMUR R/T can accept up to 10,000 pulses per second. It has a 5 digit floating decimal scale factor allowing total readout in true engineering units and rate per second, minute or hour.

Input "A" simultaneously drives a ratemeter which can be programmed to display the basic frequency (rate per second) or factored to show rate per minute or rate per hour. Simply push the "VIEW" button to see either total or rate without losing a count. Two separate 5 A relay contacts can be set to operate at either rate or total presets in a latch or auto-recycle mode with output timing from 0.1 to 99.9 seconds.

Two control outputs can be assigned to either the totalizer or ratemeter and can automatically recycle at the preset total or stay latched until reset.

Several units can communicate to a host computer on a single RS232 or RS422 loop. Each unit can be assigned it's own I.D. number.

When two inputs are received (A & B), the unit can either add or subtract the two inputs or display the two inputs as separate totalizers.

Specifications:

Display: 6 digit, 0.55" High LED

Input Power:

110 VAC \pm 15% or 12 to 15 VDC

220 VAC \pm 15% or 12 to 15 VDC

24VAC \pm 15% or 12 to 15 VDC

Current: 250 mA DC max. or 6.5 VA AC

Output Power: (AC powered units only)

Terminal 7: +12 VDC @ 50 mA, unregulated -10 + 50%

Terminal 10: +8VDC @ 50mA

Temperature:

Operating:

+32°F (0°C) to +130 F (+54°C)

Storage:

-40 F (-40°C) to +200°F (93°C)

Humidity: 0-90% Noncondensing

Memory: EEPROM stores data for 10 years if power is lost.

Inputs:

NAMUR Input:

Logic 0 < 1 mA; Logic 1 > 3 mA

Input Resistance 1000 ohms (typ.)

4-30VDC Input:

Logic 0 open or < 1V, Logic 1 > 4V

Input Resistance 10K ohms (typ.)

3N: NAMUR input on Input A

4-30 VDC input on Input B

3NB: NAMUR input on Input A and Input B

5N: NAMUR input on Input A

4-30 V Direction Control input on Input B.

5NB: NAMUR input on Input A and Input B

Direction Control input on Input B

9NB: Quadrature, accepts NAMUR inputs on Input A and

Input B with 90° phase shift for direction detection

Approvals: CSA File# LR91109-7, CE Compliant

Reset:

Front Panel:

Resets displayed value and control output

Remote:

4-30 VDC negative edge resets Totalizer "A"

and control output

Control Outputs:

Relays:

2 each N.O. Relay; 5 Amps 120/240 VAC or 28 VDC.

(N.C. relay contacts available with solder jumpers.)

Analog Output:

An optional 4-20mA (0-20mA) output is available for the NAMUR R/T series. The output can be programmed to track rate or total. This feature is available by adding suffix A to the part number. Connections are via a 2 terminal pluggable screw connector.

Programming is accomplished by using the front panel in conjunction with rear dip switches.

Accuracy: \pm .25% FS worst case.

Compliance Voltage: 3 to 30 VDC non inductive.

Scaling Factor (K-Factor): In the standard unit, a user programmable K-Factor is used to convert the input pulses to engineering units. The 5 digit K-Factor dividers, with decimal keyed into any position, allow easy direct entry of any K-Factor from 0.0001 to 99999. Separate factors may be entered for the 2 separate input channels.

Presets: Two control outputs are provided. To set relay values, press "menu" button until "Relay" appears on the display, the A and B outputs can be assigned to the ratemeter (high/low), one preset for rate and one for total, or two presets on the A and B totalizers. A 5 digit value can be entered for both presets and the decimal point location is the same as the counter. The outputs can be set to energize from 0.1 to 99.9 seconds or latch (0.0). If a value other than 0.0 is entered, the totalizers will auto reset at the preset. In the A-B or A+B versions, the relays will be assigned to either net total or A rate.

Lockout: Unauthorized front panel changes can be prevented by entering a user selected 5 digit code in the "LOC" mode. The front panel can be completely locked out or the presets can remain accessible.

SPECIFICATIONS

(continued)

DECODING PART NUMBER

Ratemeter: Accuracy: 0.01% FS (± 1 display digit).

The rate display updates once per second. The rate meter can be programmed to accept almost any number of pulses per unit of measurement, sample from 2 to 24 seconds maximum, and auto-range up to 5 digits of significant information. In the "RPS" mode, the ratemeter displays in units per second, and in the "scale" mode, units per hour or per minute. The unit will display the rate of the A Input only.

Totalizer: The two 6-digit totalizers can count at 10 kHz max. Each can have a 5-digit dividing scale factor. The totalizer advances on the positive edge of each pulse. Count up or down modes available, as are quadrature inputs from encoders for position or flow measurement. The unit can be programmed to view the net value of "A+B" or "A-B", or A and B as separate totalizers.

RS232/RS422 with KEP Protocol:

If the serial interface option is supplied, multiple units can be linked together. (The terminal addressing the unit must be capable of driving all loads in the loop.) Unit status and new set points can be communicated by serial communication. Mode changes, however, must always be made on the front panel.

Data is received and transmitted over standard EIA RS232 or RS422 levels. Unit number, baud rate and parity are entered in the "Program Setting" set up mode and remain in memory even if power is off.

RS232/RS422/RS485 with Modbus RTU Protocol:

The serial port can be used for serial printing or also for data acquisition. The unit can assign addresses up to 247 units (The terminal addressing the unit must be capable of driving all loads in the loop.) The unit can communicate with a master device through a Modbus-RTU protocol. The data given for each parameter is in IEEE float format comprising of 2 words.

The unit can be connected in a network.

Device ID: 01-247

Baud Rates: 300, 600, 1200, 2400, 4800, 9600

Parity: None, Odd, Even

Protocol: Modbus RTU (Half Duplex)

Ordering Information

Example:	NRT	A	3	1
Series:				
NRT=	6 digits, ratemeter/totalizer with presets and scaling.			
NC2=	6 digits, totalizer only with presets and scaling.			
NR2=	5 digits, rate only with presets and scaling.			
Operating Voltage:				
A=	110 VAC \pm 15% or 12 to 15 VDC			
B=	220 VAC \pm 15% or 12 to 15 VDC			
C=	24 VAC \pm 15% or 12 to 15 VDC			
Count Inputs:				
3N =	NAMUR input on Input A, 4-30 VDC input on Input B.			
3NB =	NAMUR input on Input A and Input B			
5N =	NAMUR input on Input A, 4-30 V Direction Control input on Input B.			
5NB =	NAMUR input on Input A and Input B Direction Control input on Input B			
9NB =	Quadrature, accepts NAMUR inputs on Input A and Input B with 90° phase shift for direction detection.			
Options				
1=	RS232 Communications			
2=	RS422 Communications			
3=	Modbus RTU RS232			
4=	Modbus RTU RS422/RS485			
A=	Analog Output (4-20/0-20 mA)			

NOTE: RS232/RS422/RS485 & Analog Output options can not be combined

Accessories

Separate keyboard panel - order #34242

NEMA4 wall mount enclosure available, see NEMAtr0l

Explosion proof enclosure available, see XHV

Serial printer available, see P1000, P295

Ethernet Port Server available, see IEPS

RS-422/485 to RS-232 Communication Adaptor available, see CA285

Modbus DDE/OPC Server available, see KEPServer

HOW TO MOUNT THE UNIT

The unit is designed to be mounted with a gasket providing a water tight seal. Two mounting brackets are provided to secure the unit to the panel. A panel less than .1" may distort if the clamps are screwed too tightly.

Slide the body of the unit through the rubber gasket. Insert the unit into the panel. As shown in "FIG. A", slide the brackets up the groove to press against the back of the panel. Insert screws into rear of brackets and tighten them evenly and alternately. Do not over tighten! A normal level of torque is required. Maximum torque should be 3" pounds.

This product is designed to be panel mounted and is NEMA 4 rated if proper mounting procedures are followed and the required and supplied hardware is correctly used.

If the panel in which the unit is mounted is less than .125 of an inch thick, the possibility exists that there will be some flexing. Should this flexing occur, the resulting deformation of the panel could cause a loss of the water tight seal. In case this should occur, the use of silicone or other sealant would be recommended.

This product is designed to the NEMA 4 rated. However, the fact that we are unable to control either the location in which the device is installed or the actual installation itself requires that the company's liability shall extend only to the repair or replacement of a defective product.

We are prepared to offer additional assistance in those special situations where normal mounting methods do not seem to satisfy the customers needs. This assistance may be obtained by calling the factory and asking for Application Engineering.

FIG. A

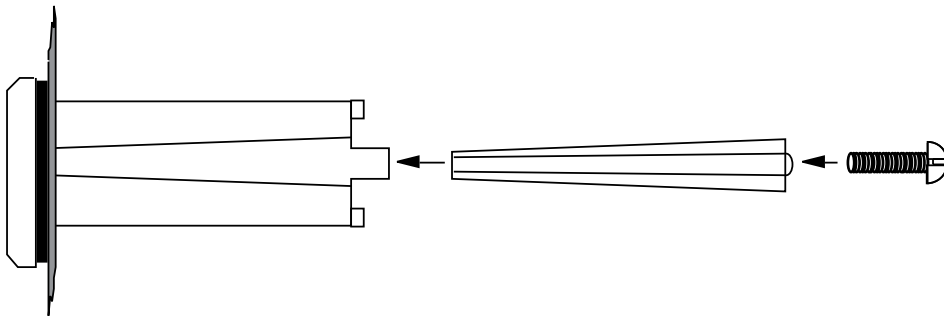

DIMENSIONS

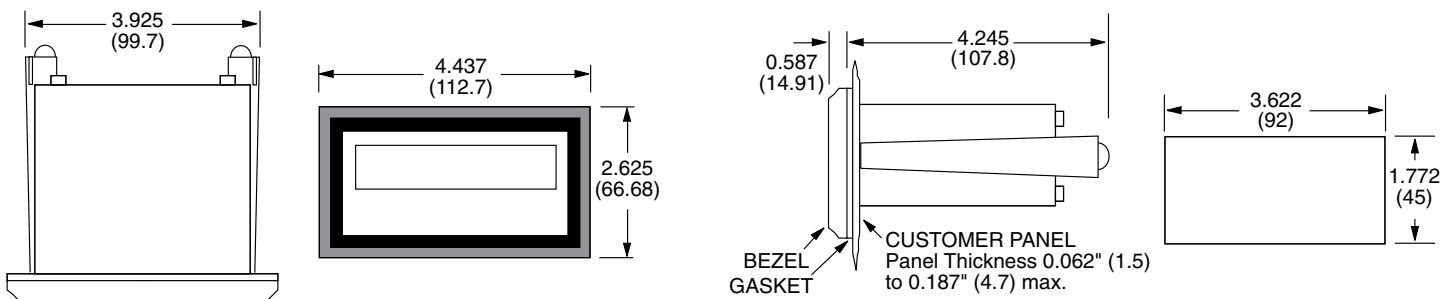

WIRING

The rear terminal contains 12 screw terminals for connecting #14 to #28 gauge wire.

The unit is controlled by a microprocessor and, therefore, an electrically "noisy" environment could cause operating problems. The input power line should not be common to power lines for motors, pumps, contactors, etc.

The unit is designed to be immune from line or RF voltage interference. In some environments voltage spikes of over 100 volts, even 1000 volts, can occur. When common to a power line driving motors voltage fluctuations can be extreme and rapid. Lines driving DC or AC solenoids, relays, or actuators can also cause problems.

Four sources of noise can occur:

- 1) AC power line noise - If the unit cannot be connected to a clean power source, an inductive load suppressing device (MOV as GE # V130LA1 or Resistor Capacitor as Paktron # .2 uf/220 ohm @ 400V) can be installed. Although locating the suppressor across the AC supply at the unit should help, best results are obtained by connecting the suppressor across the leads of the "load" at the device causing the spike.
- 2) Input line noise -The noise is carried on the input and D.C. ground lines. Make sure the input wires are never run into the unit in a bundle with power input lines. Also, keep these input lines isolated from inductive lines from devices drawing heavy loads. If there is a possibility of electrical noise, we recommend using shielded cable, with the shield being hooked to the D.C. ground terminal on the instrument, and to "earth" at one point in the circuit, preferably at the D.C. ground terminal of the unit.
- 3) Output lines - The unit has two relay outputs. When these outputs are used to run external relays or solenoids, spikes can be generated upon activation. This noise can spread through the instrument causing operating problems. If the source is a D.C. operated device, a general purpose diode (IN4004) placed across the solenoid prevents electrical noise spikes. Connect the cathode (banded side) to the more positive side of the coil. If the source is an A.C. operated device, use a MOV or Resistor Capacitor across the coil.
- 4) 12 VDC output supply - Noise can be generated on the 12 VDC output supply if it is used to drive inductive loads or if the current draw exceeds 50 mA. Insure that all inductive loads have a diode (such as IN4004) across the coil and that the current does not exceed 50 mA.

UP/DOWN CONTROL AND QUADRATURE INPUTS

QUADRATURE INPUT:

When programming the counter section for quadrature input, you must set the unit for A net B and A sub B (see step 2 in programming section). This insures proper operation. The rate can only be viewed in one direction. If the unit is a ratemeter only (NR2), connect only one of the quadrature channels to Input A (pin 5).

UP/DOWN CONTROL:

When using the up/down control option, Input A (pin 5) is the count input and Input B (pin 6) is the up/down control (direction) input. The counter must be set for A net B and A sub B (see step 2 in programming section).

When the direction input is high (4-30VDC (Input typr 5N) or >3mA (input type 5NB)) the count inputs will count up, when the direction input is low (open, <1VDC (input type 5N) or <1mA (input type 5NB)) the count inputs will count down. The direction input must precede the count input by 1 msec when the unit is set for low CPS and 1 usec when set for high CPS.

CONNECTING AC / DC POWER

NOTE: Connect power only after other connections are finished. Do not touch the live AC power terminals! The unit has been designed with an isolated AC input. Thus, polarity is not a concern for the AC input. The chassis is plastic, therefore earth ground is not used. For D.C. operation, connect + 12V to pin 7 and - D.C. to pin 8.

CONNECTING NAMUR SENSOR INPUTS

A NAMUR sensor is an electronic switch activated by a piece of metal moved close to the activation point. The sensor is a 2-wire proximity switch between two currents of <1 mA and > 3 mA. The switch is "off" if current is <1 mA, and "on" if the current is >3 mA.

TYPICAL HOOKUP

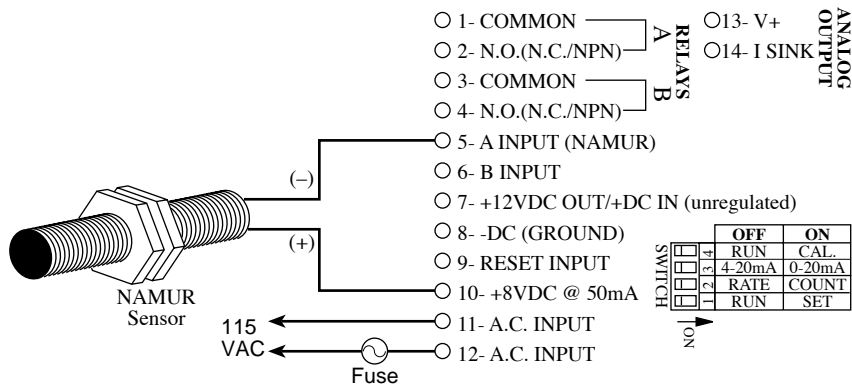

WHAT CAN YOU VIEW?

- 1) "A sub B" - If you have selected the "A sub B" mode, pressing "view" shows:
 - A) The net Total result of subtracting input B from input A. Pulses on input B will subtract (count down). Pulses on input A will add (count up) if "reset to 0" is selected, if "set to preset" is selected, input A will subtract (count down).
 - B) The rate of input A.

- 2) "A add B" - If you have selected "A add B" mode, pressing "view" shows:
 - A) The net Total result of adding "A" and "B" inputs. Pulses on input B will add (count up). Pulses on input A will add (count up) if "reset to 0" is selected, if "set to preset" is selected input A will subtract (count down).
 - B) The rate of input A.

- 3) "A sep B" - If you have selected "A sep B" mode, pressing "view" shows:
 - A) The total counts of input A. If "reset to 0" is selected A counts up, if "set to preset" is selected A will count down.
 - B) The rate of input A.
 - C)* The total counts of input B. B will always count up.

NOTE: In "A sep B" mode, B can be used in 3 ways:

- 1) As a separate totalizing counter
- 2)** As a Batch Total Counter for input A
- 3)** As a Grand Total Counter for input A

NOTE:

* All decimal points are inverted when "B total" is being displayed.

** See below on how to modify for Batch Count and "B" as a Grand Total Counter.

OUTPUT JUMPER SELECTIONS

FUNCTION	MODIFICATION	
"A" RELAY N.C. OUTPUT	CUT AT "A"	JUMPER "B" TO "2"
"B" RELAY N.C. OUTPUT	CUT AT "D"	JUMPER "E" TO "4"
* "A" PRESET TRANSISTOR (NPN)	CUT AT "A"	JUMPER "C" TO "2"
* "B" PRESET TRANSISTOR (NPN)	CUT AT "D"	JUMPER "F" TO "4"
"B" AS BATCH COUNTER	SELECT "A SEP B"	JUMPER "H" TO "G"
"B" AS GRAND TOTAL COUNTER	SELECT "A SEP B"	CONNECT PULSES TO "A" & "B"

BOTTOM VIEW AT TERMINAL

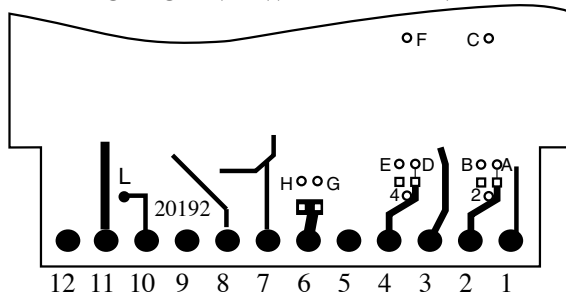

* The unit must be removed from the case to access jumpers C & F, all other jumpers can be accessed by removing the plastic extender.

NOTE: All three pads at jumpers 2 and 4 are connected.

OPERATING THE FRONT PANEL

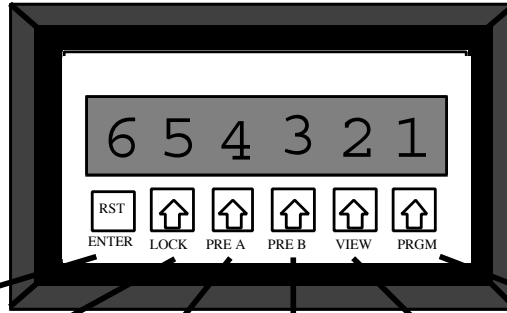

Press to "reset" in operating mode. Press to "enter" in programming mode.

Press to enter lock code for panel lock.

Press to view or change preset A.

Press to view or change preset B.

Press to alternately view A rate & net total or A rate, A total & B total.

Press to cycle through PROGRAM choices. Press to toggle between choices in program mode.

PROGRAMMING FLOWCHART

NOTE: Several programming selections will not appear with NC2 and NR2 units.

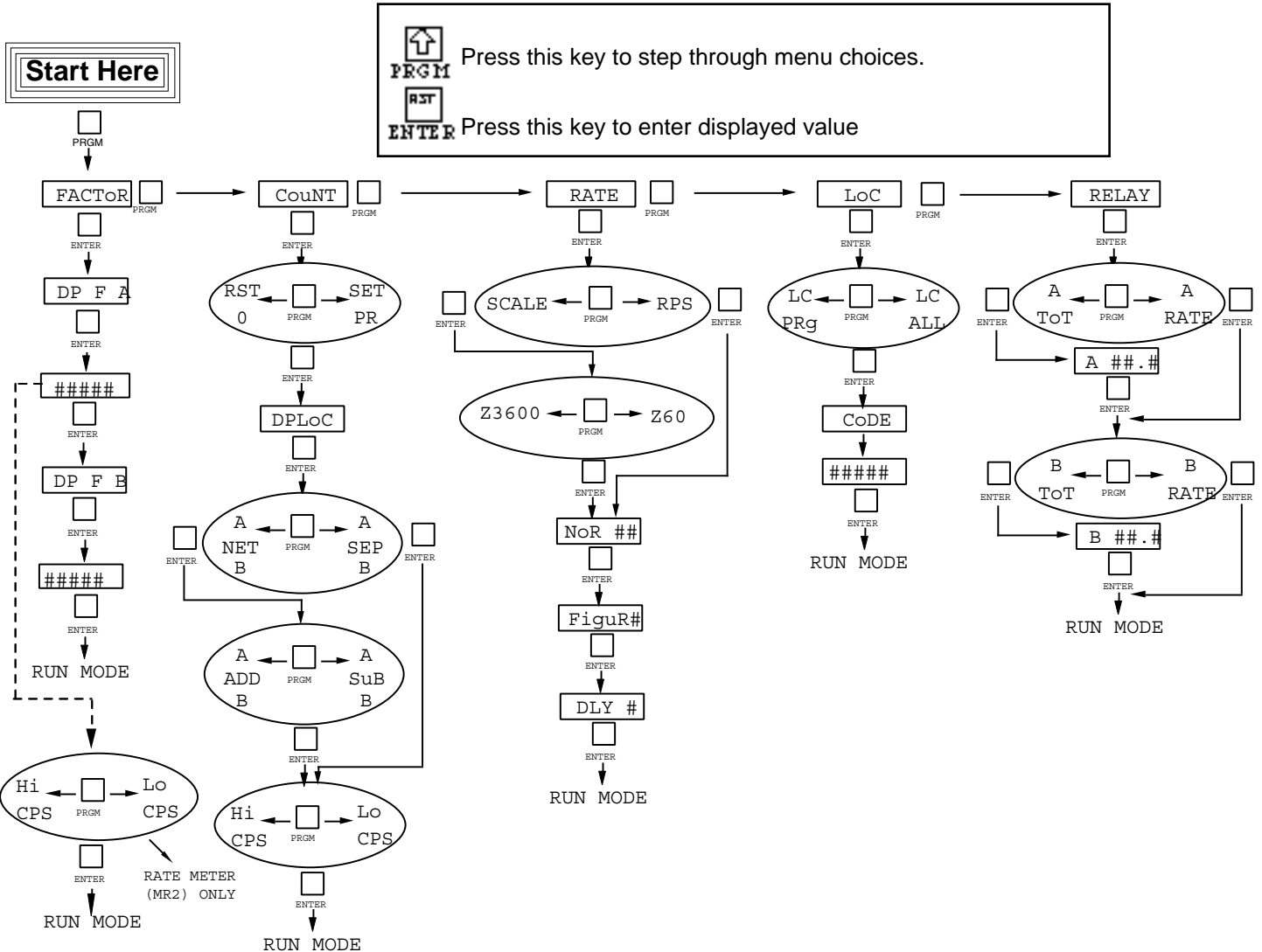

The following is a list of abbreviations as they appear on the display and front panel of the unit.

ABBREVIATION	DESCRIPTION
FRCtor	SCALING FACTOR - For A and B Inputs. Each input has a separate 5 digit dividing scale factor.
dP F A	DECIMAL POINT FOR FACTOR A - Enter location of decimal point for scaling Factor A by pressing the button under the digit where the decimal is desired.
dP F b	DECIMAL POINT FOR FACTOR B - Enter location of decimal point for scaling Factor B by pressing the button under the digit where the decimal is desired.
COUNT	PORTION OF MENU FOR SETTING COUNTER VARIABLES
rSt 0	RESET TO 0 - Counter will reset to 0. Input A will count up from 0. Input B will subtract (count down) in A Sub B mode. Input B will add (count up) in A Add B mode.
SEt Pr	SET TO PRESET - Counter will reset to preset A. Input A will count down from preset A. Input B will count up (add) in "A add B" mode and input B will count down (subtract) in "A sub B" mode.
dP Loc	DECIMAL POINT LOCATION - Enter desired location of decimal by pushing the button under the digit where the decimal is desired. Changing the decimal will change the decimal location in the A & B counters as well as the rate display.
RnEt b	NET RESULT OF ADDING OR SUBTRACTING A & B INPUTS
RSEp b	A & B INPUTS ARE SEPARATE - A & B are not added or subtracted.
RSub b	A SUBTRACT B - The number of scaled pulses from Input B are subtracted from the number of scaled pulses from Input A. (-99999 TO 999999)
RAdd b	A ADD B - The number of scaled pulses from the A Input are added to the number of scaled pulses from the B Input.
HicPS	HIGH COUNTS PER SECOND - This sets the unit for high count speeds (0-9.99KHz)
LoCPs	LOW COUNTS PER SECOND - This sets the unit for contact debounce filtering (0-40Hz)
rRtE	PORTION OF MENU FOR SETTING RATE VARIABLES
rPS	RATE PER SECOND - The display will read in rate per second.
SCALE	SCALING - Allows unit to display rate per minute or rate per hour.
≡ 60	DIVIDE K FACTOR BY 60 - This sets the unit for rate per minute; equal to 60 times rate per second.
≡ 3600	DIVIDE K FACTOR BY 3600 - This sets the unit for rate per hour; equal to 3600 times rate per second.
nOr ##	NORMALIZING FACTOR - Normalizes (averages) the data being received. Higher settings provide more normalizing (averaging) for a more stable display. Derived from the equation: $\frac{\text{Old Data} \times \text{"NOR"} + \text{New Data}}{\text{"NOR"} + 1}$
Figur ##	SIGNIFICANT FIGURE - This sets the amount (1-5) of meaningful figures the unit will display. (RATE DISPLAY ONLY). FOR EXAMPLE: If "2" is set as the figure, a rate of 273.45 will be displayed as 270.
dLY##	DELAY FACTOR - The amount of time (02 to 24 sec.) the unit will "look" for valid data, before the display defaults to zero. (RATE DISPLAY ONLY)

- LOCK - This portion of the menu allows you to:
 - 1) lock the program (presets are still accessible)
 - 2) lock all (presets and program are locked).
- LOCK PROGRAM - This will lock the program and allow the presets to be changed when the unit is in the lock mode.
- LOCK ALL - This will lock the program and the presets when the unit is in the locked mode. The presets can be viewed, but not changed.
- LOCK CODE - This message (code) will flash on display for approximately 3 seconds. It will be followed by a 5 digit number (xxxxx). The number you enter here will be the code to lock and unlock the unit.
- RELAY - This portion of the menu allows you to set your relay operation variables.
- RELAY A FOR TOTALIZER - When this is selected relay A will activate when the net total has reached Preset A ("A NET B" Mode). Relay A will activate when the total of input A reaches preset A ("A SEP B" Mode).
- RELAY A FOR RATE - When this is selected relay A will activate when the Rate of input A equals or exceeds preset A when in "A NET B" or "A SEP B" mode. The relay will drop out when the rate of A falls below preset A.
- RELAY A DURATION - This message will appear when "A TOT" is selected. It is the duration which the relay will remain energized (00.1 to 99.9 sec). If 00.0 is selected, the relay will latch until reset. When the duration is not at 00.0, the unit will autorecycle.
- RELAY B FOR TOTALIZER - When this is selected relay B will activate when the net total has reached preset B ("A NET B" Mode). Relay B will activate when the total of input B has reached preset B ("A SEP B" Mode).
- RELAY B FOR RATE - When this is selected relay B will activate when the rate of input A equals or exceeds preset B when in "A NET B" or "A SEP B" mode. The relay will drop out when the rate of A falls below preset B.
- RELAY B DURATION - Follow same procedure as A ###.

TERMINATIONS

- 1- COMMON
- 2- N.O.(N.C./NPN)
- 3- COMMON
- 4- N.O.(N.C./NPN)
- 5- A INPUT (NAMUR)
- 6- B INPUT
- 7- +12VDC OUT/+DC IN (unregulated)
- 8- -DC (GROUND)
- 9- RESET INPUT
- 10- +8VDC @ 50mA
- 11- A.C. INPUT
- 12- A.C. INPUT
- 13- V+
- 14- I SINK

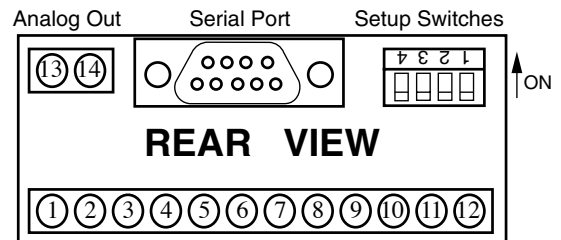
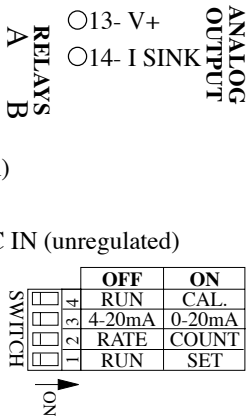

CALCULATING SCALE FACTORS

There are two separate dividing scale factors, one for input "A" and one for input "B". The factor to enter is the number of pulses per the desired unit of measurement. The factor ranges from 0.0001 to 99999. The factor is the same for rate and count on input "A". Because the "units per second", "minute", or "hour" are field programmable from the keypad, scale factor calculations for the ratemeter are easy. Here are some examples:

SCALING FACTOR EXAMPLES:

BATCHING: You want to count the number of batches (10 boxes each) being loaded onto a pallet.
Solution - Dial in a scale factor of 10.

UNIT COUNTING: You pick up a notch on a paper roll (1 pulse per shaft revolution). Each revolution equals 3 feet. To find the number of pulses per foot, simply divide "1 pulse" by "3 feet" ($1 \div 3 = .3333$).
Solution - One foot equals 0.3333 pulses, enter this as the scale factor and the display will read in feet.

RATE: The shaft of a motor has a flywheel with 10 spokes. The KEP DO series prox switch is mounted to sense 10 pulses per revolution. RPM of the shaft is the desired readout.
Solution: Enter a Factor of 10 and for every 10 pulses, "1" will appear on the display. Set rate per second, minute or hour as desired.

A conveyor carrying bottles must be controlled for bottle speed. For each revolution of the front roller, three bottles travel by. Thus, one revolution equals 3 bottles. A wheel with seven spokes is mounted on the roller. The user can't sense bottles because they are traveling through a washer, so a sensor is placed at the roller, sensing seven pulse per revolution of the shaft, which equals 3 bottles per revolution.
To calculate the scale factor ($7 \text{ ppr} \div 3 \text{ bottles}$) = 2.3333 scale divider. Set rate per second, minute or hour as desired.

A flow meter is generating 52.6 pulses per gallon. The desired readout is in liters. Since there are 3.785 liters per gallon, divide 52.6 by 3.785 to find the number of pulses per liter ($52.6 \div 3.785 = 13.897$).
Enter 13.789 as the scale factor so the display will read in liters.

An aluminum sheeting plant has a cut to length application to customer specification. A ten pulse per revolution encoder with a 12" wheel is used to sense. The travel of aluminum sheets is in inches. Thus, after 10 pulses, you want 12 to appear on the display. Thus, $10 \div 12 = .8333$. Enter .8333 as your scale factor.

PROGRAMMING

STEP
1
SETTING
SCALING
FACTORS

*THIS SECTION
WILL ONLY AP-
PEAR IN THE
RATE METER
ONLY (NR2)
VERSION*

<u>PRESS</u>	<u>DISPLAY</u>	<u>REMARKS</u>
<input type="checkbox"/> PRGM	FACtor	This section of the menu is used to set up the scaling factors for inputs A & B.
<input type="checkbox"/> ENTER	dP F A	This sets the decimal for factor A. Press the arrow key under the digit where the decimal is desired. To clear the decimal, press the arrow key furthest to the right (PRGM) .
<input type="checkbox"/> ENTER	#####	This is the scaling factor for input A. To change, press the arrow key under the digit(s) to change. Press ENTER to enter the displayed value.
<input type="checkbox"/> ENTER	Hi CPS or Lo CPS	This section will only appear in the RATE only version. Press the PRGM key to choose HIGH CPS (0-9.99KHz) or LOW CPS (0-40Hz). Press the ENTER key to enter the displayed choice.
<input type="checkbox"/> ENTER	dP F b	This sets the decimal for factor B. Press the arrow key under the digit where the decimal is desired. To clear the decimal, press the arrow key furthest to the right (PRGM) .
<input type="checkbox"/> ENTER	#####	This is the scaling factor for input B. To change, press the arrow key under the digit(s) to change. Press ENTER to enter the displayed value.





STEP
2
SETTING
THE
COUNTER

<u>PRESS</u>	<u>DISPLAY</u>	<u>REMARKS</u>
<input type="checkbox"/> PRGM	FACtor	This section of the menu sets up the counter information.
<input type="checkbox"/> PRGM	Count	
<input type="checkbox"/> ENTER	RSt 0 or SEt Pr	Press the PRGM key to choose RST 0 (reset to 0, count up) or SET PR (set to preset, count down), press the ENTER key to enter the displayed choice.
<input type="checkbox"/> ENTER	dP Loc	This sets the decimal location for the A & B counters. Press the arrow key under the desired digit location. To clear the decimal, press the arrow key furthest to the right. Press the ENTER key to enter the displayed location.
<input type="checkbox"/> ENTER	ANet b or ASEP b	Press the program key to choose A NET B (add or subtract A & B) or A SEP B (view A & B as separate counters). Press the ENTER key to enter the displayed choice.
<input type="checkbox"/> ENTER	ASub b or AAdd b	This section will only appear if A NET B was selected. Choose A SUB B (A subtract B) or A ADD B. Press the ENTER key to enter the displayed choice.
<input type="checkbox"/> ENTER	Hi CPS or Lo CPS	Press the PRGM key to choose HIGH CPS (0-9.99KHz) or LOW CPS (0-40Hz). Press the ENTER key to enter the displayed choice.

STEP
3
SETTING
THE RATE

<u>PRESS</u>	<u>DISPLAY</u>	<u>REMARKS</u>
<input type="checkbox"/> PRGM	FACtor	
<input type="checkbox"/> PRGM	Count	
<input type="checkbox"/> PRGM	rAtE	This section of the menu is used to set up the rate information.
<input type="checkbox"/> ENTER	rPS or SCALE	Press the PRGM key to choose RPS (rate per second) or SCALE (RPM, RPH). Press ENTER to enter displayed choice.
<input type="checkbox"/> ENTER	≡ 60 or ≡ 3600	Press PRGM to choose ÷60 (RPM) or ÷3600 (RPH). Press ENTER to enter displayed choice.
<input type="checkbox"/> ENTER	nor ##	This sets the normalizing (averaging) factor. Press the arrow keys under the desired digits to change. Press ENTER to enter displayed value.
<input type="checkbox"/> ENTER	Figur #	This sets the number of significant figures to be displayed. Press the arrow key under the digit to change. Press ENTER to enter displayed value.
<input type="checkbox"/> ENTER	dLY #.#	This sets the delay time (2 to 24 sec.) that the unit will "look" for valid input data before the display falls to 0. Press the arrow key under the digits to change. Press ENTER to enter displayed value.

**STEP
4
SETTING
LOCK**

<u>PRESS</u>	<u>DISPLAY</u>	<u>REMARKS</u>
 PRGM	FACtor	
 PRGM	Count	
 PRGM	rAtE	
 PRGM	LoC	This section of the menu is used to set up the lockout type and code.

 ENTER	LC PG or LC ALL	LC PG = Locks program but presets and re-set are accessible. LC ALL= Locks entire keypad. Press the PRGM button to toggle between choices; Press ENTER to enter displayed choice.
--	-----------------------	---









 ENTER	CoDE Flashes followed by: #####	After CODE flashes the display will show the existing lock code. To change the code press the key under each digit to be changed. Press ENTER to enter displayed value.
--	--	---

**SETTING
THE
LOCK
STATUS**



 LOCK	CoDE Flashes followed by: 0	Key in the lock code (see programming step 4) by pressing the keys under the digits to be changed. Press the ENTER key to enter the displayed code.
---	--------------------------------------	---

 ENTER	LoC or unLoC	After the code is entered the unit will display LOC (unit is locked) or UN LOC (unit is unlocked). This message will be displayed for approximately 3 seconds before the unit returns to the run mode.
--	--------------------	--

**STEP
5
SETTING
THE RE-
LAYS**

<u>PRESS</u>	<u>DISPLAY</u>	<u>REMARKS</u>
	FACTOR	
	Count	
	rATE	
	LoC	
	rELAY	This section sets up the relay information.
	A tot or A rATE	Press the PRGM key to choose A TOT (A assigned to total) or A RATE (A assigned to rate). Press enter when the desired choice is displayed.
	A ##.#	This is the duration (.1 to 99.9 sec) that relay A will remain energized. If 00.0 is selected, the relay will latch until reset
	b tot or b rATE	Press the PRGM key to choose B TOT (B assigned to total) or B RATE (B assigned to rate). Press enter when the desired choice is displayed.
	b ##.#	This is the duration (.1 to 99.9 sec) that relay B will remain energized. If 00.0 is selected, the relay will latch until reset

**SETTING
THE
PRESETS**

	PRE A Followed by last PRE A entered	PRE A = Preset A (Final Preset); The set point at which output A will trigger. If the displayed value is not the desired preset, press the key(s) under the digit to be changed.
	PRE B Followed by last PRE A entered	PRE B = Preset B (Prewarn); The set point at which output B will trigger. If the displayed value is not the desired preset, press the key(s) under the digit to be changed.

OUTPUT WIRING

The following diagrams detail the connection of the relay and analog output options. Each relay consist of a form A contact (Normally Open). NPN transistor or Normally Closed contacts are available with solder jumpers (see Jumper Options).

SOLENOID

Use Relay A (pins 1 & 2) for output to a solenoid valve. When the count or rate (selectable) reaches Preset A, Relay A will energize. When Relay A closes, current passes through the solenoid for activation. When operating AC solenoids, we recommend the use of an MOV to reduce inductive kickback (use a diode for DC solenoids).

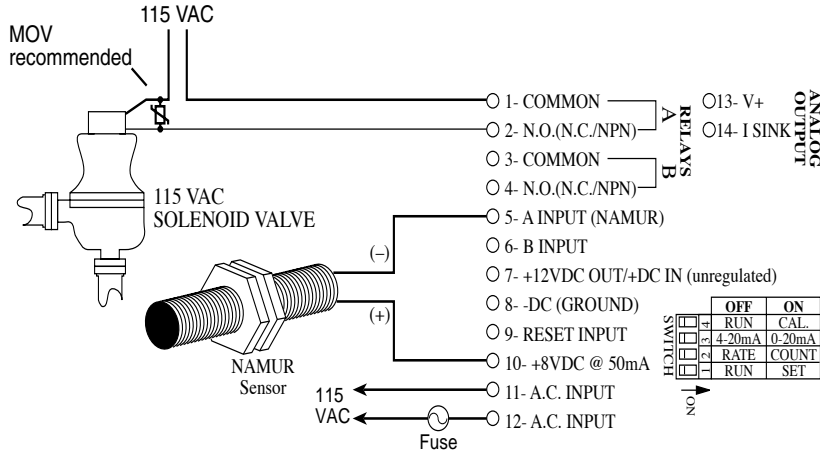

ANALOG OUTPUT

The analog output can be selected to output 4-20 mA or 0-20 mA and can be selected to track the rate or count. Pin 13 supplies 12 to 18V to power the current loop. Pin 14 supplies the current sinking driver. When connecting a strip chart recorder, make connections as follows:

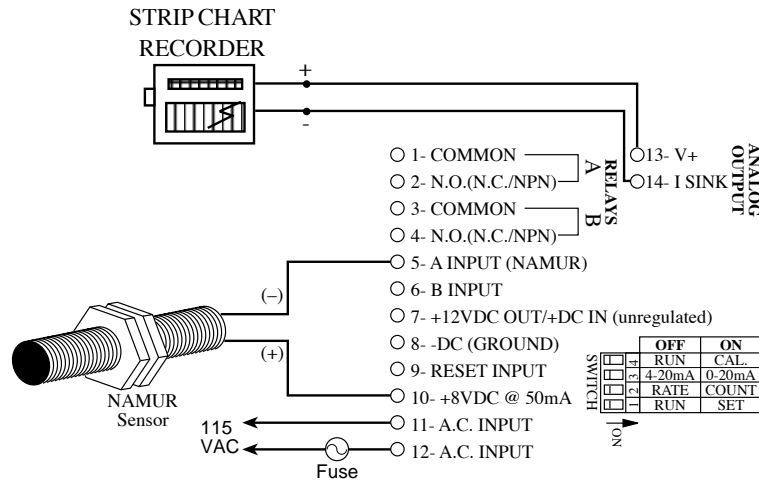

ALARMS

The relays can be used to trigger alarms which warn the operator that the preset Total amount has been reached or the rate has exceeded a set speed. The outputs are programmable to be assigned for rate or count. When assigned to the count, the relays can have a user selectable on time (duration) or can be latched until reset.

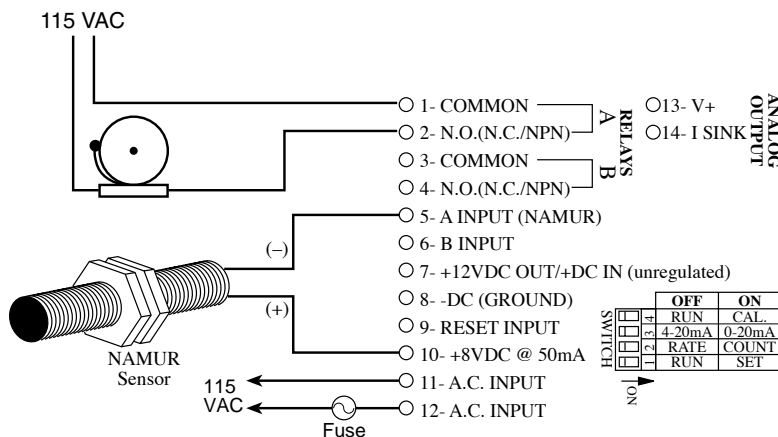

ANALOG OUTPUT OPTION

Description:

An optional 4-20mA (0-20mA) output is available. The output can be programmed to track rate or total. This feature is available by adding suffix A to the part number. Connections are via a 2 terminal pluggable screw connector.

Connections: (see FIG. 1)

PIN13 supplies the 12 to 18 VDC to power the current loop.
PIN14 is the control sink driver

Accuracy:

50uA worst case

Compliance Voltage:

3 to 30 VDC non conductive

Setup:

The optional analog output feature uses 4 dip switches on the back for setup. These switches are used as follows:

SW1 - View or change "set low" and/or "set high" values

SW2 - Select output for rate or total

SW3 - Select 4-20mA or 0-20mA

SW4 - Calibrate the unit.

After the regular parameters shown in the programming flowchart have been set, locate the 4 switches on the back of the unit. (see FIG. 1)

Switch Settings:

SWITCH 1: Enter Analog Low & High (normally off)

Switch 1 is used to load in the low (4mA or 0mA) and/or the high (20mA) output settings. With power on, set switch 1 ON (up).

LOW SETTING is viewed or changed by pressing PRE A. If the displayed value is correct, press ENTER. If not, press buttons A through E to step to the desired value and press ENTER. (disregard the display which will show the last count reading).

HIGH SETTING is viewed or changed by pressing PRE B. If the displayed value is correct, press ENTER. If not, press buttons A through E to step to desired value and press ENTER.

Return switch 1 to OFF (down) position, PRE A and PRE B buttons now function to view or change relay trip values.

SWITCH 2: Select Count or Rate

SW2 OFF (down): Analog output follows rate

SW2 ON (up): Analog output follows count

SWITCH 3: Select 4-20mA or 0-20mA

SW3 OFF (down): Selects 4-20mA output range

SW3 ON (up): Selects 0-20mA output range

SWITCH 4: Calibrate (normally off)

Switch 4 is used for calibration. Calibration is done at the factory and should not be needed (see SWITCH 1 to enter high and low values). If recalibration is desired, a calibrated 20mA ammeter with 1uA resolution is needed. Attach the "+" lead of the meter to pin 13 and the "-" lead to pin 14. Set switch 4 ON (up). The unit will output approximately 20.000mA and a decimal will light in the third position. Read the output using the ammeter. Press PRE A. If the display is the same as the ammeter reading, press ENTER. If not, press buttons A through E to step to ammeter reading and ENTER. (Disregard display which now shows the last count reading with decimal point in third position) Return switch 4 to OFF (down) position.

RS232 & RS422 Operation:

When the unit is supplied with RS232 or RS422, the analog output "low" and "high" settings can be accessed and changed through the serial port. The codes are as follows:

AL Unit will display (transmit) analog out "low" value.

AL(S)XXXXX Unit will load analog out "low" with entered number. (S) = space

AH Unit will display (transmit) analog out "high" value.

AH(S)XXXXX Unit will load analog out "high" with entered number. (S) = space

FIG. 1

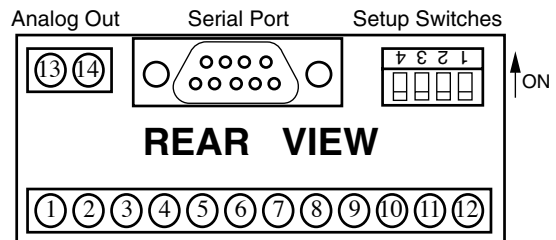

Typical Wiring:

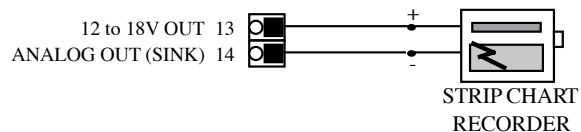

INTERFACE CARD RS 232/422 OPERATION

RS 232/422 SET-UP:

All serial communication mode changes must be done through serial communications. Mode changes cannot be done through the front panel. To initialize the unit, place a jumper between pin 7(+12V)[bottom board] and pin 1(init)[DB -9 connector] on initial power up. The unit defaults to: 300 baud rate,"MARK" parity and device number 01. To enter the program mode you must set your terminal for 300 baud rate and "MARK" parity. Next, type D1(s), **(s)= space bar**. The unit will echo back "DEVICE #1:". Now type EP (enter program) and a carriage return (enter). The unit will echo back "PROGRAM SETTING". You are now in the programming mode.

SETUP PROCEDURE:

The following sections consist of the communications setup options as they appear in the menu. (If you wish to exit the program mode, at any time you can hit the "escape key" (Hex Code: 1B) and the unit will save the changes made but not effect the remaining data values.) When each section of the setup menu is displayed, the current data will appear in the < > signs. If you wish to change the data, type in the number of the desired choice and press return (enter). If you wish to keep the current data, simply press return.

DEVICE NUMBER:

Each unit in the hook-up must be assigned it's own device number (1 to 99). Zero is reserved for a dedicated hook-up to only one terminal, and it's transmit output line remains in an "on" active state. The device number is entered in the program mode. The unit will prompt you:

DEVICE# <XX>?

If XX is the desired device number press return (enter), if not enter the desired number after the question mark and press return (enter).

BAUD RATE:

The baud rate is the speed at which data is transmitted, expressed in bits per second. Baud rates of 300, 600, 1200, 2400, 4800 or 9600 are available. When in the baud rate section of the menu, the unit will list :

BAUD RATES:

1:300 2:600 3:1200

4:2400 5:4800 6:9600

then prompt you:

BAUD RATE <300>?

Press return (enter) if this is the desired baud rate or enter the assigned number of one of the six possible baud rates. If an invalid baud rate is entered the unit will prompt you to choose another baud rate. This will occur until a valid baud rate is entered or escape is pressed.

PARITY:

Parity is a bit of information that is inserted before the stop bit and is used to help check if the transmission is correct. When setting the parity you may select "ODD" (parity bit is logic 0 if total number of logic 1's in the first seven data bits

is odd), "EVEN" (parity bit is logic 0 if total number of logic 1's in the first seven data bits is even), "MARK" (parity bit is always logic 1 - High / Mark) or "SPACE" (parity bit is always logic 0 - Low / Space). If a "MARK" parity is chosen, it will appear that two stop bits are used. Use the "MARK" parity with terminals using parity "OFF" or "NONE". These terminals ignore the parity. The unit does not check the parity but does transmit the parity chosen. When setting the parity, the unit will print:

PARITIES:

MARK-0 SPACE-1 EVEN-2 ODD-3

Then the unit will prompt you:

PARITY<MARK>?

If this is the desired parity press return (enter), if isn't enter the number of the desired parity then press return (enter).

STROBE LIST:

The serial interface card is also equipped with a strobe line. When the strobe line is triggered, a chosen set of data will be transmitted to be displayed or printed. The selections for the display list are entered in the program mode. Enter "1" to add selections to the list and enter "0" to delete selections from the list. The seven available items for the strobe display list are: (1) Preset A, (2) Preset B, (3) K-Factor A, (4) K-Factor B, (5) Rate of A, (6) Count A, (7) Count B. In the "A net B" mode Count A will display the Net Count and Count B is an invalid command and the unit will transmit useless data.

When setting the strobe list the unit will print :

ENTER STROBE LIST:

DO NOT DISPLAY-0 DISPLAY-1

The unit will prompt you:

PRESET A<DISPLAY>?

PRESET B<DISPLAY>?

K-FACTOR A<DISPLAY>?

K-FACTOR B<DISPLAY>?

RATE<DISPLAY>?

COUNT A<DISPLAY>?

COUNT B<DISPLAY>?

If the above choices are entered, when the strobe line is triggered (3-30V positive pulse) the unit will transmit:

DEVICE# 1:

PA XXXXX

PB XXXXX

KA XXXXX

KB XXXXX

DR XXXXXX

DA XXXXXX

DB XXXXXX

(SEE COMMANDS BELOW FOR DESCRIPTION OF COMMAND CODES).

Each time the strobe line gets triggered the unit will transmit this data unless the program mode is entered and the strobe list altered.

After these four items have been entered they will remain unaltered unless the program mode is entered again and the values changed. The unit is now set and must be addressed by it's device number to come on line again.

SERIAL INPUT COMMANDS:

To get a unit on line you must address it by it's device number. This is done by typing DXX(S), XX= device number. The unit comes on line and echoes back DEVICE# XX. Insure that "DEVICE# XX:" is received before requests are sent. The unit is now ready to receive a command or string of commands separated by a space. A carriage return (enter) will enter the commands and processing of requests begins. The carriage return (Hex Code "D") puts the unit "off line" after data is processed.

COMMANDS:

- EP.....Unit will enter program mode.
- DA.....Unit will display (transmit) Count A.
- DB.....Unit will display (transmit) Count B.
- DR.....Unit will display (transmit) rate A.
- KA.....Unit will display K-factor A.
- †*KA(S)XXXXX....Unit will load K-factor A with entered number.
- KB.....Unit will display K-factor B
- †*KB(S)XXXXX....Unit will load K-factor B with entered number.
- PA.....Unit will display Preset A.
- †PA(S)XXXXX....Unit will load Preset A with entered number.
- PB.....Unit will display Preset B
- †PB(S)XXXXX....Unit will load Preset B with entered number.
- RA.....Counter A will reset
- †*RA(S)XXXXXX...Unit will set Counter A to entered number.
- RB.....Counter B will reset.
- †*RB(S)XXXXXX...Unit will reset Counter B to entered number.

***THE UNIT WILL RECOGNIZE A DECIMAL IF ONE IS PLACED IN ANY OF THESE DATA VALUES.**

†THE UNIT WILL ONLY RECOGNIZE THE LAST FIVE DIGITS ENTERED (SIX DIGITS FOR RA & RB).

The following is an example of requests and responses:

<u>Transmit from terminal</u>	<u>Receive from unit</u>
	(s)=Space
D5(s) [Unit #5 Activated]DEVICE# 5:	
PA(s)12345(s)PA	PA 12345 PA
KA(s)1576(s)KA	KA 1576 KA
KB(s)6751(s)KB	KB 6751 KB
RA(s)RB[RETURN]	RA RB
(UNIT PRESETS AND A & B K-FACTORS ARE SET AND BOTH COUNTERS ARE RESET)	
12345	
	1576
	6751

SERIAL INTERFACE OPERATION:

Data is received and transmitted over standard EIA RS232 or RS422 levels. Each ten bit character is made up of a start bit, seven bit ASCII code, a parity bit and a stop bit. Device number, baud rate, parity and strobe list are entered in the program setup mode and will remain in memory even if power is lost.

The input impedance of RS232 is 3KΩ to 7KΩ worst case. The terminal addressing the unit must be capable of driving all loads in the loop. The input impedance of RS422 is much higher and there should be no problem driving as many as 99 units. The transmit line remains in a high impedance "off" state until addressed. Only one unit is to be on line at a time!!! More than one unit on line could damage the unit or destroy the transmitted data.

When the unit is active (on line) it will operate in a full duplex, echo back mode, so that data sent from the terminal will be transmitted back for verification. When the unit is "on line", use the proper serial transmit commands to request data or set a new value. Up to 80 characters of data can be linked together and transmitted to the unit in a string as long as there is a space between the commands. If an error is made, a correction can be made by back spacing and retyping correct data before the return (enter) is sent. Once a return (enter) is sent, the unit begins processing the data and will transmit the requested data on a non-priority basis over the data transmit line. A keypad entry or incoming data will halt the data communication cycle. Therefore, there should be a pause after data is requested to insure that all data has been transmitted before making another request or addressing another unit. If the unit is not busy, it should not take longer than 300 msec to process each request. To find the cycle time to process and transmit a request, calculate the bit transmit time by using this formula: [(1÷ baud rate) x (80) + .005] x number of requests made. This time will be extended if the unit must service the front keypad. If transmission has not started within two seconds after data is requested, it can be assumed that there is a problem. The unit transmits a carriage return and line feed after each data value. Any new communication must be started with DXX(S) (device number and space).

RS232/RS422 - IBM-PC INTERFACE:

The following program is for IBM basic to set up RS232/RS422 on serial port (#1) at 300 baud. Run this program after connecting the serial interface connections.

```

10 SCREEN 0,0:WIDTH 80
20 CLS:CLOSE
30 OPEN "COM1:300,n,7,1,CS,DS,CD" AS #1
40 ON ERROR GOTO 110
50 B$=INKEY$
60 IF B$< >" THEN PRINT #1,B$;
70 IF EOF (1) THEN 50
80 A$=INPUT$ (LOC(1),#1)
90 PRINT A$;
100 GOTO 50
110 RESUME

```

RS232 / RS422 WIRING

RS-232 HOOKUP:

When connecting the unit to a computer with RS 232 communication, only three connections are needed. These connections are: Receive data, Transmit data and Ground. The connections should be made as follows:

DP -9 CONNECTOR

Transmit data (pin 2)
Receive data (pin 3)
Ground (pin 5)

COMPUTER

Receive data
Transmit data
Ground

RS-232 PINOUT

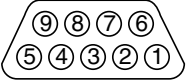

- 1•INIT.
- 2•TX
- 3•RX
- 4•N/C
- 5•GND
- 6•STRB
- 7•N/C
- 8•N/C
- 9•N/C

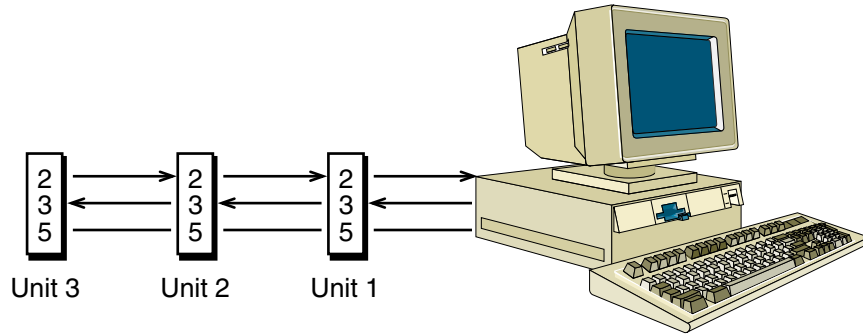

RS 422 HOOKUP:

When connecting the unit to a computer with RS 422, five connections are needed. These connections are: Receive data A (+), Receive data B (-), Transmit data A (+), Transmit data B (-) and Ground. The connections should be made as follows:

DP -9 CONNECTOR

Transmit data A(+) (pin 2)
Transmit data B(-) (pin 7)
Receive data A(+) (pin 3)
Receive data B(-) (pin 8)
Ground (pin 5)

COMPUTER

Receive data A(+)
Receive data B(-)
Transmit data A(+)
Transmit data B(-)
Ground

RS-422 PINOUT

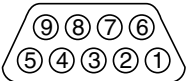

- 1•INIT.
- 2•TX (+)
- 3•RX (+)
- 4•N/C
- 5•GND
- 6•STRB
- 7•TX (-)
- 8•RX (-)
- 9•N/C

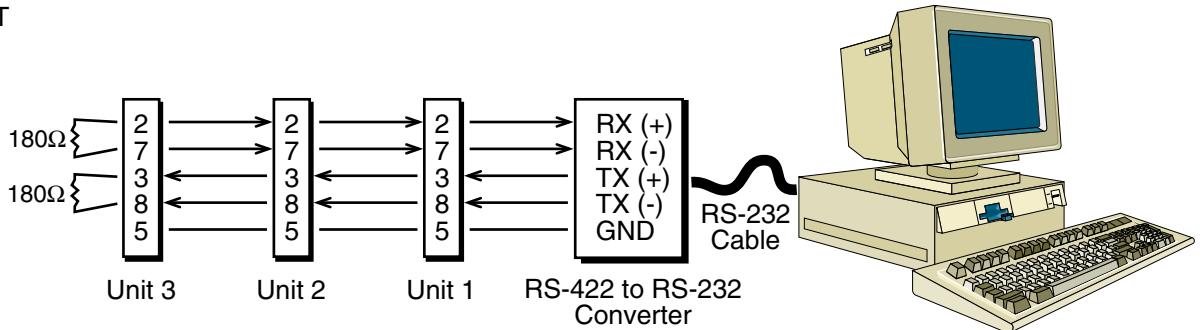

PRINTER HOOKUP:

When connecting the unit to a printer, you must first program the desired baud rate, parity and strobe list with a computer. After the unit is programmed it can be connected to the printer. Connect the transmit line(s) of the unit to the receive line(s) of the printer and be sure that both devices have common grounds. When the strobe line is triggered the unit will transmit the selected strobe list which you had previously programmed.

RS 232

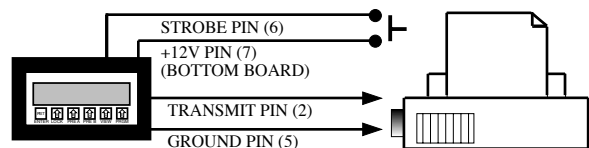

RS 422

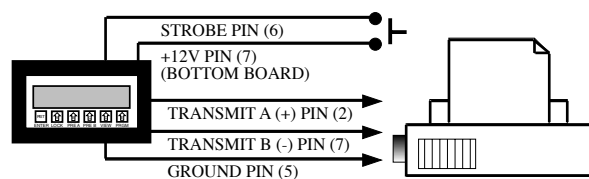

TROUBLESHOOTING GUIDE

<u>PROBLEM</u>	<u>POSSIBLE CAUSES</u>	<u>SOLUTIONS</u>
Power is applied to unit but the display does not light.	1. AC or DC power wiring is incorrect.	1. Recheck power wiring
Unit works, but occasionally the display freezes or skips counts.	1. Line noise is affecting the processor due to a current spike or surge.	1. Use a different power supply or install a surge suppressor.
Input signal is connected but the unit does not count or display rate.	1. Input wiring is incorrect. 2. Scale factors are incorrect. 3. Transmitting device is defective. 4. Wrong debounce filtering selected. 5. Unit is defective.	1. Recheck input wiring. 2. Recheck scale factors and factor calculations. 3. Replace transmitting device. 4. Recheck debounce filtering selection "hi cps" or "lo cps". 5. To confirm set scale factors at one and connect a wire to pin #7 and touch it to pin # 5 (input A). Each time pin #5 is touched counter A should count once. If not, call factory for RMA. (this test will not work on units with quadrature input)
Rate is displaying: r FFFFF.	1. The unit is trying to display a number which it can't (too small or too large). 2. Line noise affected unit on power up.	1. Check scaling factor, if it is correct, lower the number of significant figures. 2. Reprogram the unit and be sure to enter a decimal (enter one and re move it if a decimal is not desired).
Relays are not activating properly.	1. Wrong relay duration. 2. Relay set for wrong activation i.e. count instead of rate.	1. Recheck programmed relay duration. 2. Recheck programmed relay activation mode.
Counter resets before reaching 999999.	1. Relay duration is set at a value other than 00.0. This causes the counter to auto-reset at the preset.	1. If relay outputs are not being used, set the relays for rate (NRT) only. 2. Set the relay durations to 00.0.
Various menu items are not being displayed.	1. The menu flow chart and the setup steps show the setup for the units with rate and total (NRT). When using a unit which has only count (NC2) or only rate (NR2,) several menu items will not be displayed.	1. The menu items which do not appear are not used for the models without the ratemeter (NC2) or without the counter (NR2). Therefore, disregard any menu items which appear on the flowchart and setup steps, but do not appear on the unit's display.