

BAT R/T MILLENNIUM

Features

- UL/C-UL Intrinsically Safe Listed
- Accepts Inputs From: Magnetic Pickups, Contact Closures, DC Pulses (Optically Isolated) from Pulse Producing Flowmeters
- Displays Rate & Total Simultaneously
5 Digit Rate Display, 8 Digit Totalizer Display
- 4-20mA Analog Output Option (8 updates/sec)
- Powered From Internal Battery, External DC Supply or 4-20 mA Output Loop
- 20 Point Linearization (optional);
10 Point Linearization with Data Logger option
- Isolated Scaled Pulse Output

Description

Featuring 5 digits of rate and 8 digits of total, the BAT R/T Millennium edition (BATRT-M) is a battery or loop powered indicator capable of accepting magnetic pickup, DC pulse and switch closure inputs from pulse producing flowmeters. The unit can be ordered with an optional 4-20mA output. The BATRT-M uses the 4-20mA loop to provide power when this output is used.

Specifications

Power:

BATTERY POWERED

Supplied with 1 or 2 C size Lithium battery pack.

EXTERNAL POWER INPUT

Voltage: 8.5 to 30 VDC

Current: Less than 5 mA

Supplied with 1 C size lithium battery

Protection: Reverse Polarity Protection on DC Power Input

LOOP POWERED

Voltage: 8.5 to 30 VDC

Supplied with 1 or 2 C size lithium battery(ies)

Protection: Reverse Polarity Protection on Current Loop

Loop Burden: 8.5V maximum

BATTERY LIFE EXPECTANCY:

Expected Years of Operation for BATRT-M of various powering options at equipment duty cycles

MODEL	RUN TIME			
	Idle	2hrs/day	8hrs/day	24hrs/day
BATRT-M-A	10 yrs	10 yrs	10 yrs	9.1 yrs
BATRT-M-A-4	10 yrs	10 yrs	10 yrs	8.4 yrs
BATRT-M-B/C	10 yrs	10 yrs	10 yrs	10 yrs
<u>standby-operation</u>				
BATRT-M -B/C	Indefinite operation when externally powered			
External or loop power				

NOTE: Battery shelf life is rated at 10 years by manufacturer. Life expectancy based on rated battery capacity at 20°C. The above table is shown with pulse output inactive. Use of pulse output shortens battery life. Example: A pulse output of 0.06 sec. duration, once per second, would derate the battery life by 20%.

DISPLAY:

Rate Display: (selectable decimal)

5 Digits (99999), 0.35" High, Display updates once per second with battery power, 8X per second with DC or Loop power

Rate Descriptors: /SEC, /MIN, /HR
/MIN, /HR, /DAY with "D" option

Min. Input Frequency: 0.01 Hz to 10 Hz (selectable delay of 0.1 to 99.9 seconds) Selectable Rate Display Damping

Battery or Loop Powered Ratemeter & Totalizer



- Nonvolatile Flash Memory of Setup Data
- RS485 Modbus RTU Communications and Data Logger (optional)
- Setup Software Available for Easy Programming and Monitoring Using a PC and Special Serial Cable

Totalizer Display: (selectable decimal)

8 Digits (99999999), 0.2" High

Totalizer Descriptors: GAL, LIT, FT3, M3, "blank"

GAL, BBL, MCF, M3, "blank" with "D" option

Warning Displays: Low battery warning

PULSE OUTPUT:

The pulse output advances with the least significant digit of the totalizer or decimal multiples thereof (see Pulse scale divider).

Type: Isolated photomos relay

Max. voltage (off state): 30 VDC

Current (on state): 100mA

Pulse Duration: Selectable 0.5, 0.25, 0.125, 0.0625 seconds

Pulse Scale divider (Pulscale): User selectable, ÷1, ÷10, ÷100 or OFF

NOTE: Select OFF for max. battery life.

ACCURACY:

0.01% Reading, ±1 count

Temperature Drift: 50 ppm/°C Worst Case

SAFETY LISTINGS:

UL/C-UL File E225832

CLASS 1, DIV 1, GROUPS B, C, D

See Installation DWNG 17075-1

ENVIRONMENTAL:

OPERATING TEMPERATURE

-4°F (-20°C) to +158°F (70°C)

Extended Temp: -22°F (-30°C) to +158°F (70°C)

HUMIDITY

0 - 90% Noncondensing

MOUNTING STYLES:

- 0- Circuit Board - OEM option (consult factory)
- 1- Panel Mount - NEMA 4X Front
- 2- Wall Mount - NEMA 4X Enclosure (keypad mounted behind clear cover)
- 3- Explosion Proof - Class I, Division I, Groups B, C & D
Class II, Division I, Groups E, F & G
- 5- Wall Mount - NEMA 4X Enclosure (keypad mounted on cover)
- 6- Double Ended Explosion Proof - Class I, Division I, Groups B, C & D
Class II, Division I, Groups E, F & G (contact factory for details)

NOTE: Meter mounting kits available for styles 2, 3 and 5
Consult Factory

INPUTS:

MAGNETIC PICKUP INPUT

Frequency Range: 0 to 3500 Hz
Trigger Sensitivity: 10 mV p-p
Over Voltage Protected: ± 30 VDC

OPTO-ISOLATED DC PULSE INPUT

High (logic 1): 4-30 VDC
Low (logic 0): Less Than 1 VDC
Minimum Current: .5 mA
Hysteresis: 0.4 VDC
Frequency Range: 0 to 5 kHz
Min. Pulse Width: 0.1 msec

CONTACT CLOSURE INPUT (contact closure to common)

Internal Pullup Resistor: 100 KΩ to +3.6 VDC
High (logic 1): Open or 4-30 VDC
Low (logic 0): Less Than .5 VDC
Internal Switch Debounce Filter: 0 to 40 Hz

NOTE: Sustained contact closure will shorten battery life.

RESET INPUT (contact closure to common)

Internal Pullup Resistor: 100 KΩ to +3.6 VDC
High (logic 1): Open or 4-30 VDC
Low (logic 0): Less Than .5 VDC
Minimum On : 25 msec

NOTE: Sustained contact closure will shorten battery life.

K-FACTOR

Range: 0.001 to 99999999
Decimal Point Locations: XXXX.XXXX to XXXXXXXX

20 Point Linearization Option (10 Point with Data Logger option)

This feature allows the user to enter 20 different frequencies with 20 different corresponding K-Factors to linearize non linear signals.

ANALOG OUTPUT OPTION:

Type: 4-20 mA follows rate display, Two wire hookup
Accuracy: 0.025% Full Scale at 20° C
Temperature Drift:
50 ppm/°C Typical
Reverse Polarity Protected
Update Rate: 8 times/second

NOTE: The BATRT-M uses the 4-20 mA loop power as its primary power source when this option is used. The battery is still required for standby battery operation.

DATA STORAGE:

Setup Information: Stored in flash memory
Totalizer: Stored in battery backed RAM but can be saved to flash memory by operator for recall after battery change out.

COMMUNICATIONS OPTION (S1):

RS232 SERIAL SETUP SOFTWARE OPTION:

This option enables you to access a variety of process parameters through serial communications. PC compatible communications software is included with this option. With this software and a BAT R/T-M Serial Adapter Cable (BSAC1) you will be able to setup the BAT R/T-M through your PC.

RS-485 MODBUS and DATA LOGGER OPTION (S2):

The optional RS-485 card utilizes Modbus RTU protocol to access a variety of process parameters. The Data Logger stores the totalizer to flash memory once every 24 hours at the time you set. The data logger can hold 27 days of totals, on the 28th day the oldest total in the logger is dropped. Requires external DC power: 6-28VDC (input is reverse polarity protected)
Current Draw:
Receiving: 2 mA
Transmitting: 125 mA (instantaneous peak)

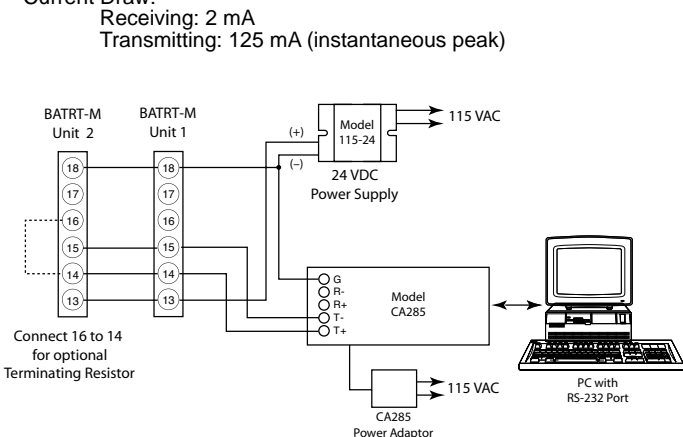

Typical Wiring:

CONTACT INPUT / PULSE OUTPUT / BATTERY POWERED
(Power option A or B)

DC In (+) 12 1 Mag Input 1
Not Used (-) 11 2 Mag Input 2
Opto Input (+) 10 3 Shield/Common
Opto Input (-) 9 4 Reset Input
Opto Out (+) 8 5 Contact Input
Opto Out (-) 7 6 Common/ DC In (-)

MAG INPUT / 4-20 mA LOOP POWERED
(Power option C or AC)

4-20mA (+) 12 1 Mag Input 1
4-20mA (-) 11 2 Mag Input 2
Opto Input (+) 10 3 Shield/Common
Opto Input (-) 9 4 Reset Input
Opto Out (+) 8 5 Contact Input
Opto Out (-) 7 6 Common

MAG INPUT / BATPACK POWERED
(Power option A or B)

DC In (+) 12 1 Mag Input 1
Not Used (-) 11 2 Mag Input 2
Opto Input (+) 10 3 Shield/Common
Opto Input (-) 9 4 Reset Input
Opto Out (+) 8 5 Contact Input
Opto Out (-) 7 6 Common/ DC In (-)

MAG INPUT / DC POWERED
(Power option A or B)

DC In (+) 12 1 Mag Input 1
Not Used (-) 11 2 Mag Input 2
Opto Input (+) 10 3 Shield/Common
Opto Input (-) 9 4 Reset Input
Opto Out (+) 8 5 Contact Input
Opto Out (-) 7 6 Common/ DC In (-)

BATPACK

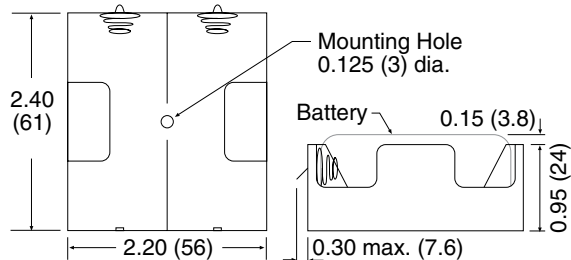

BATRT-M-0

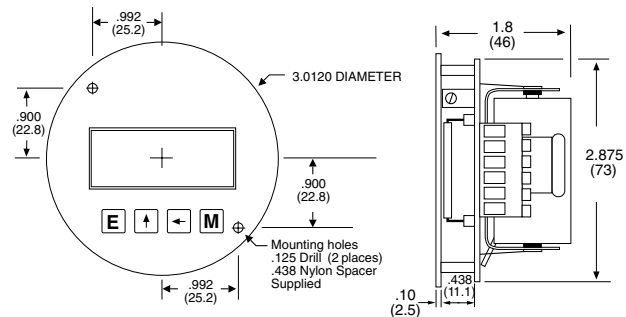

BATRT-M-1

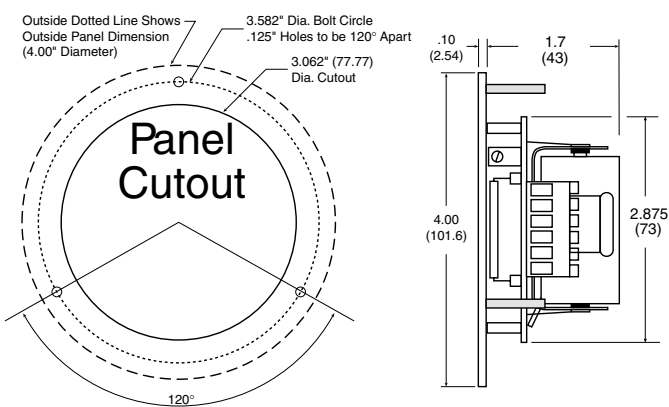

BATRT-M-2

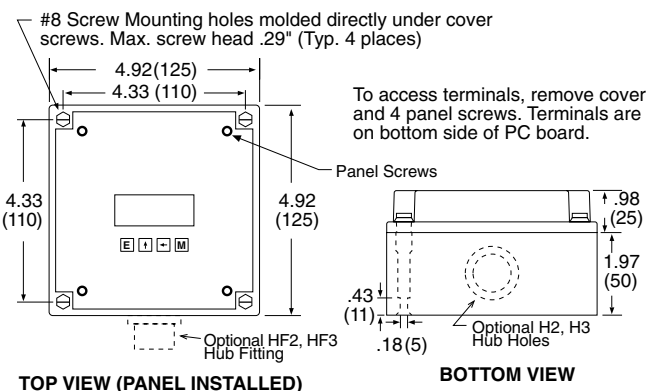

BATRT-M-3

To access terminals, unscrew cover and loosen 2 panel screws. Terminals are on bottom side of PC board.

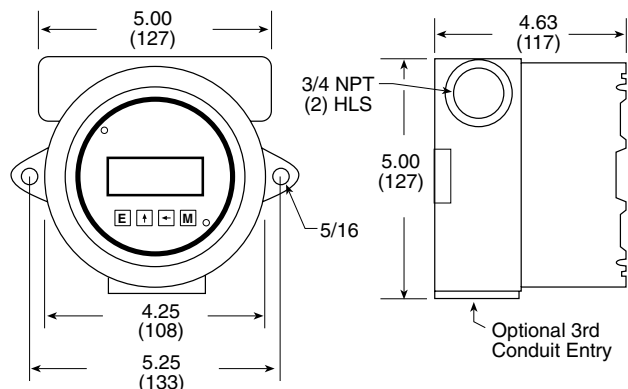

BATRT-M-5

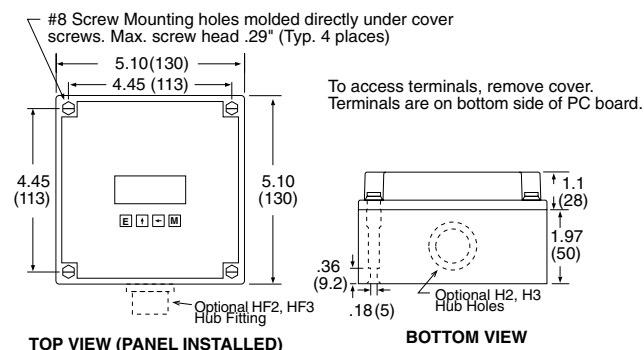

Ordering Information

EXAMPLE:	BATRTM	3	A	4	ET
Series:					
Mounting:					
* 0 = OEM					
* 1 = Panel Mount					
2 = NEMA 4X Box (Bat R/T-M behind clear cover)					
3 = Explosion Proof Housing					
5 = NEMA 4X Box (Bat R/T-M outside opaque cover)					
6 = Double Ended Explosion Proof Housing (consult factory)					
Power Supply:					
* A = Battery (2 supplied)					
B = External Power Supply (8.5 to 30 VDC)					
C = Loop Powered with 4-20 mA Output					
AC = Loop Powered with 4-20 mA Output and 2 Batteries					
Options (Multiple Options Available)					
S1 = Serial Setup Software for use with BSAC1					
S2 = RS485/Modbus/Data Logger - Isolated (power options B, C only)					
4 = 20 Point Linearization (10 point with S2 option)					
D = Rate per Day, Hour or Minute					
ET = Extended Temp.: -22°F to 158°F (-30°C to 70°C)					
CE** = CE Compliant					
CSA** = CSA Listed Explosion Proof					
IS** = UL/C-UL Listed IS					
TRX = NEMA7 Explosion Proof Reset Switch (mounting style 3 only)					
RN = External Magnetic Reset					
T = Third Conduit Entry in Ex-Proof Housing (mounting style 3)					
H2 = 0.875" Hole for mounting styles 2 and 5					
HF2 = 0.5" Female NPT Hub fitting for mounting styles 2 and 5					
H3 = 1.125" Hole for mounting styles 2 and 5					
HF3 = 0.75" Female NPT Hub fitting for mounting styles 2 and 5					
Accessories:					
BATPACK= External Batt. Pack with 2 C Size Batteries & 12" leads					
BATC = Single Battery: Tadiran P/N TL2200/S 3.6V 7200mAh or equal					
115-24 = 115 VAC to 24 VDC power supply					
BSAC1 = RS232 Serial Adapter Cable with setup software					

NOTE: Additional entry holes may be provided on styles 2 and 5.