

**Problems**

**Possible Cause / Solution**

- |   |   |
|---|---|
| <p>6. MOH works but audio does not stop when call is picked up in A1 or A3 settings.</p>              | <ul style="list-style-type: none"> <li>• Wire distance to adapter is too long, Centralize the location of device to be as close as possible to all the phones. Try the A2 setting.</li> <li>• If you are re-wiring “daisy chain” wiring works better than ” star” or “home run” or Independent wiring</li> <li>• Press FLASH button to stop the music.</li> </ul>   |
| <p>7. Some Phones work , some do not</p>  | <ul style="list-style-type: none"> <li>• All your phones need to be similar model for activation in A1...A3 settings. If you mix different phone models, Use the B1, B2 settings or Voice Activation in C1, C2 settings. Refer to pages 4 or 5 for more details.</li> </ul>   |
| <p>8. Randomly Hold music starts to play by it self or does not activate in A1, A2 or A3 settings</p> | <ul style="list-style-type: none"> <li>• The call needs to be on Hold min. 2 sec. before you may pick it up.</li> <li>• When you hang up, wait 2 seconds before selecting the same line again.</li> <li>• Check for extra devices sharing that line like Message indicator, Answering machine, Alarm system, Modem etc. Use a “privacy module” between the line and that extra device to keep them off the line when line is being used by your phone.</li> <li>• Set your Alarm system and/or your DSL line to share FAX line.</li> <li>• <u>Excessive wiring</u>- Total wire length per line must be under 500 feet ( Ex: if you have 9 wall jacks -no matter spare or a phone plugged in- each connected via a 100 foot wire to a common point then your total wire length is 9 x 100=900 feet )</li> <li>• Use FLASH button to deactivate music.</li> </ul> |
| <p>9. Audio shuts off or flickers</p>   | <ul style="list-style-type: none"> <li>• Extensive audio volume. Lower the volume to proper level.</li> </ul>   |
| <p>10. Hold Music activates in a conference call or when two phones pick up at same time</p>          | <ul style="list-style-type: none"> <li>• If for any reason the hold music is activated inadvertently, it can always be deactivated by pressing the FLASH button in any setting.</li> <li>• Conference calls can be done a better way: Press FLASH, you will get a dial-tone now dial the phone number of the 2<sup>nd</sup> party then press FLASH to join the two calls together.</li> </ul>   |



**Music-On-Hold Adapter Installation**

**Model # SX8400** Rev 24A

- Plug the included AC adapter. (110V AC to 12V AC)
- Confirm that all 4 LED lights on this unit are **BLINKING**
- Connect “PHONE LINES” jacks to your “Wall” Jacks using the provided cords
- Observe that as you connect the wall jacks the blinking lights turn OFF (on non existing lines the lights keep blinking and that is OK)
- You may use a splitter (T adapter) at the Wall jack to connect both this device and the telephone. If you do not have a splitter use the “TELEPHONE” jacks on this device to plug the telephone (use Telephone “1/2/3” and/or Telephone “3/4 “ to plug your telephone in). **Please note that just one telephone is optionally connected to this device, other telephones remain connected to their own wall jacks.**
- Plug one end of the audio cable into the RCA AUDIO IN jack on the SX8400, plug the other end of cable into the audio out jack of your audio source such as the connector on digital player (8 ohm or 600 ohm -preferred), Radio, CD player, PC sound card speaker output, etc. We recommend you to set the volume on your audio source to mid level.

(please note some music titles are not royalty-free and you may want to use the royalty-free music titles to avoid annual licensing payments to ASCAP and BMI for playing those titles on-hold)

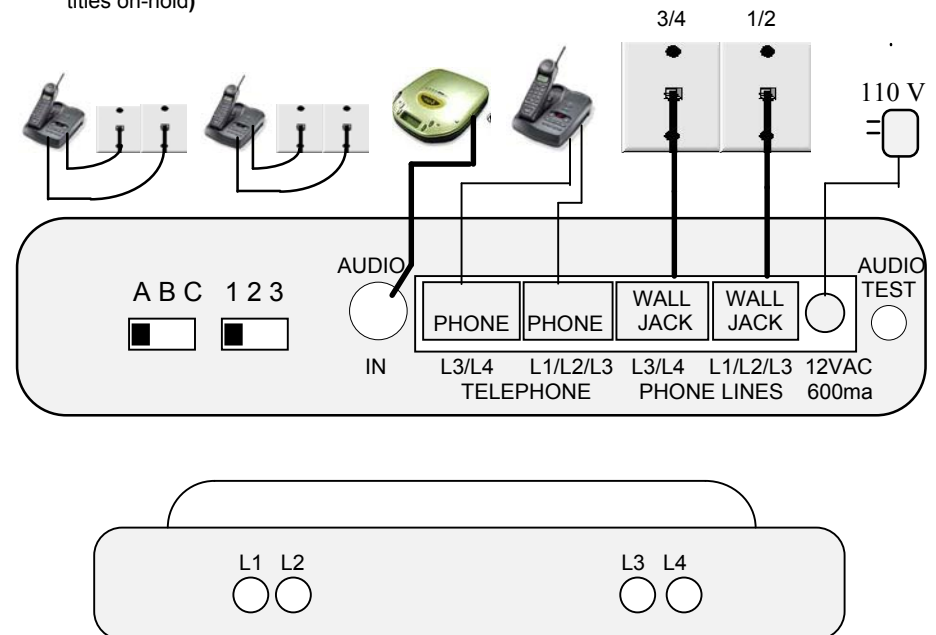

**Connection Test:** To confirm that you have connected everything correctly, select line 1 on the phone, confirm that L1 Red LED on SX8400 turns ON then press the L1 Audio Test button to hear the audio. Double check your connections or adjust the volume on your audio source if needed.

**Switch setting:** Please Read the Operation instructions for each setting carefully

There are two 3 position switches on the SX8400 that control the activation method, you need to select the proper setting based on your type of phones:

**A1, A2, A3: Hold button activation**

Use one of these settings when all phones are corded & are same model (for example all are ATT 984) and are compatible with Hold button activation (see the list in page 3) for GE 2-9487GE2-A, GE 2-9488GE2-A & RCA 25403 RCA use the B3 setting.

**B1, B2:** These two settings utilize **Flash then Hold** activation method, this setting supports any phone and any mix of brands with instant activation after you press the Flash then Hold

- Use B1 or B2 settings if your phones are Cordless type (including corded base station + portables)
- If you have mixed cordless type phones with corded type phones
- If you have corded type phones that are not all the same model for example ATT brand and Panasonic brand are both used in your office
- If you have non compatible corded phones (for example ATT 962 or ATT 972 or Casio phones)

**C1, C2: Voice Activation Mode** These two settings utilize **Delayed Hold activation** method, most phones cordless or corded or mixed can be activated for music on hold in less than 15 seconds after you press HOLD. There is also

**C3: Voice Activation or Flash** See page 5 for full details.

**IMPORTANT NOTE:** The audio may activate in the middle of a call due to factors like excessive wiring (see page 8 item 8), bad or old wiring, existing unstable lines, sparks, too many wall jacks, Noisy phone lines, Bad telephones, "Hot Lines" (see P6 special cases)

If that ever happens, press the **FLASH** button to stop the audio! and continue your conversation. The **FLASH** button is found on every telephone, it could be labeled as **CALL WAIT / FLASH** or **LINK** or **ON** or **TALK** button

**Audio Test on Line 1:** select L1 on your phone and press the **Audio Test** switch located next to power connection. Adjust the volume to mid level or check the audio cord to hear the audio.

Note1: You can not perform audio test on lines 2, 3 or 4

Note2: Do not set the volume too loud it may flicker or shut off the on-hold audio.

Note3: Do not use a Cell phone to setup or test the device. Use a fax line, etc.

**Trouble Shooting:**

Problems	Possible Cause / Solution
1. Adapter not working or stopped working	<ul style="list-style-type: none"> <li>• Unplug the 12VAC plug from the back of the Invotel adapter and unplug the phone lines; Wait 60 seconds then plug them back in, make sure the AC adapter is plugged in securely.</li> </ul>
2. Adapter does not activate or stopped activating	<ul style="list-style-type: none"> <li>• telephone was changed or power failure - <u>do as above</u>, then select L1, L2, L3, L4 making sure that dial tone is there.</li> </ul>
3. Red LED double blinks ON then turns OFF on some lines	<ul style="list-style-type: none"> <li>• Some phone Lines are removed from MOH adapter or do not exist. on non existing lines the lights keep blinking and that is OK)</li> <li>• Un-plug phone lines for 5 seconds and plug it back in .</li> </ul>
4. No Audio or Audio not Loud enough	<ul style="list-style-type: none"> <li>• Select the line 1 on the phone and push the Audio Test button located in the back of unit to hear the Audio, adjust the volume on your audio source if needed to hear it. Check the audio cord, Unplug -Plug back.</li> <li>• Use CD player "head phone" jack - not "line out"</li> </ul>
5. Audio Test is OK but no audio when Hold is pressed in <u>A1 A2 or A3</u> settings.	<ul style="list-style-type: none"> <li>• If answering a call allow 1 second before pressing Hold.</li> <li>• You may need your "Local service" with the dominant phone company in your area (not 3<sup>rd</sup> party local service)</li> <li>• Is your location within city limits? are all your phone numbers DSL qualified? your location may need to be close enough to your phone company's central office to guarantee for Hold button activation. That is why some discount phone companies service does not work even though you have compatible phones for Hold activation. If so, use the device in B1 or B2 setting via Flash then Hold or C1, C2 settings with delayed activation.</li> <li>• Some telephones need other settings via Hold(see page 6).</li> <li>• Try the unit in B1,B2 or C1,C2,C3 settings.</li> </ul>

## Other settings:

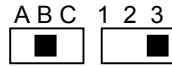

for **GE 2-9487GE2-A** , **GE 2-9488GE2-A** and **RCA 25403** phones use the B3 setting and follow the instructions on page 3 it should work by just pressing the HOLD button, if still it did not work use the B1 or B2 settings Via Flash then Hold-see page 4 for full details, these two models of GE phones beep every 3 seconds and do not work in C1 or C2 settings.

**Special Case:** If audio activates suddenly in A1 or A2 switch settings , your lines may be “too powerful” Try A3 setting.

## Operation in Hold activation:

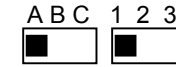

Hang up and set left switch to A position

Start with A1, make or receive a real call, the LED on the SX8400 turns ON solid, then simply press the **(HOLD)** button on your telephone, the Music will be heard to the caller and the LED on the SX8400 will start to BLINK , to return to the call just re-select that line. (Be sure to allow 1 or 2 seconds before putting a call on HOLD). If it did not work hang up and try it again 2 or 3 times.

**A2:** if after 2 -3 times it is not working hang up and change the switch to A2 and try it 2-3 times. **A3:** this setting works better on smaller offices with just a few phones, it is not as powerful as A1 or A2, if your phones work fine in A3 just leave it in A3.

**Deactivating hold music manually** If for any reason the hold music is activated inadvertently, it can be deactivated by pressing the **(FLASH)** button

The following are examples of phones that work in B1, B2 or C1,C2,C3 settings: American Venture, ATT 962, ATT 972, Casio any model , Airway 2 line, Airway 4 line, Panasonic KX-TG 2000B, KX-TG4000B, KXTG2000, KX-TG2720, KX-TG2730, KX-TG2740, KXTG4000, KX-TGA200, KXTGA400, KX-TGA420, SBC 410,

## List of corded phones compatible via Hold Button activation:

Please note: This is a partial list, there are other factors relevant to activation via Hold button in these settings-see-the trouble shooting section or special setting, If your phone is not on this list try it any way or use the B1, B2 or C1, C2 settings. B1, B2 works on all phones.

**AT&T:** 21070, 262, 272, 412, 422, 4952, 612, 622, 712, 722, 732, 742, 752, 812, 822, 830, 832, 842, 843, 853, 854, 874, 902, 912,922, 944, 945, 952, 953, 954, 955, 964, 974,984, 982, 992, SIGNATURE, FT483

**Brother Quatro:** 412

**Bell:** 223, 232, 259, 261, 268, 367, 470, 52905, Sonecor 412, 412CID, 4900, BE5200, BE5300, Techline 420

**GE:** 187, 2-9315-A, 2-9318, 2-9435-A -B -C, 2-9436-A, 2-9438-A, 2-9450-A -B -C -D -E -F, 2-9439-A to -EGL, 2-9451A, 2-9481, 2-9487GE2-A, 2-9488, 2-9638-A, 2-9975, 2-9488GE2-A

**IBM:** 412, 412CID, 4900

**Northern Telecom:** Unity

**Phonemate:** PMG-4600

**Panasonic:** KX-T3110 3120 3122 3135 3145 3155 3160 3165 3170 3175 3280 3980-H 3980-R7 3981, KX-TC930, KX-TS20, KX-TS21, KX-TS25, KX-TS27, KX-TS208, VA-8400

**Radio Shack:** 206, 208, 209, 210, 212, 411, 412, 612, 43-373D, 43-430, 43-642, ET-180, 43-470, ET-184, ET-192, ET-193, 43-622, 43-469, 1710, 1753

**RCA 25403 RCA**

**Sony:** IT-M804

**SBC:** 2105, 4000

**Southwestern Bell:** FT325, FT360, FT365BL FT383, FT412, FT483, FT484

**Sprint/Radio Shack:** SP-702 / 43-5702, SP-705

**TT Systems:** 4012, 412, 412CID, 4900, 4300, 5100, 5200, 5300, 7993

**Vtech:** 4121

Tip: If you have audio flicker problem , Reduce the Volume on your audio source

## Warranty

This product is warranted against defects for a period of one (3) year from the date of original invoice. We will repair/replace the Product with no charge for parts or labor within this time. To obtain warranty service the Product needs to be returned freight prepaid by the customer with a copy of original invoice. This warranty does not apply if in the sole opinion of Innovative Telecommunication Technology, the product has been tampered with or damaged by lightning or any other acts of nature, misuse, neglect or unauthorized service.

EXCEPT AS SPECIFICALLY PROVIDED IN THIS AGREEMENT, THERE ARE NO OTHER WARRANTIES, EXPRESSED OR OTHERWISE, INCLUDING, BUT NOT LIMITED TO ANY IMPLIED WARRANTIES OR MERCHANTABILITY OR FITNESS FOR A SPECIAL PURPOSE. IN NO EVENT SHALL INNOVATIVE TELECOMMUNICATION TECHNOLOGY (INVOTEL) BE LIABLE FOR LOSS OF PROFITS OR BENEFITS, INDIRECT, SPECIAL, CONSEQUENTIAL OR OTHERWISE ARISING FROM ANY BREACH OF THIS WARRANTY OR OTHERWISE.

## Operation in B1, B2 settings:

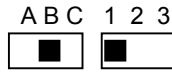

Hang up and set left switch to middle and right switch to left

To activate: press **FLASH** then **HOLD**

To deactivate just re-select that line and press **FLASH**

**Voice Deactivation:** if the call has been on Hold at least a few seconds, it can also be deactivated by just **speaking** over the Audio for example say : “Hi I am Back” .

If for some reason you are not able to voice -deactivate, try speaking a little louder and more direct into the microphone, if that does not work hang up and set the switch to **B2**. Remember you can always use the Flash button to deactivate the audio as well.

**Want to use just one button ?** Press **FLASH** to activate MOH and when ready to go back to caller just speak over the audio!. Or press Flash again. Note: this does not hold the line so the other party may still hear you, set the volume louder to mask it.

In **B1** or **B2** or **C3** settings the Flash button is used in order to activate the audio so if you have: **Call waiting , 3 way calling, Centrex Call Transfer**

Use **FLASH FLASH** to access an out side line or to answer a call waiting call etc.

**Example 1 ( B1 or B2 settings )** to take a call waiting call press **FLASH FLASH**

**Example 2 ( B1, B2 )** to make a 3 way or conference call press **FLASH FLASH** you will get a dial-tone now dial the desired phone number & press **FLASH FLASH** to join the two calls together.

**NOTE:** If you have “**Call Waiting**” service, only one call may be placed on Music-On-Hold, the other call is held in the phone company central office in silence not in your office.

## Operation in C1, C2 or C3 settings:

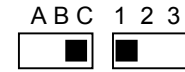

Hang up and set left switch to right and right switch to left

These settings use “**voice activation**” method, this mode of operation supports most phones or brands by just using the Hold button but with slightly longer activation time (about 10 to 15 seconds after hold is pressed)

In “**Voice activation**” mode, the device needs to hear you well therefore speak as close as possible to the microphone, If you are on a speakerphone or using a headset speak clearly and louder into the microphone. Be sure to read the NOTES in this section.

To **activate:** after you receive or make a call, you need to speak and say something before pressing the **HOLD** button. Audio activates less than 15 seconds later and the corresponding L1 ... L4 light on this device will start blinking.

To **deactivate** hold music Just re-select that line and **Speak Over** the audio, for example say : “*Hi I am Back*”, the moment the device hears it will stop the hold-music.

Note: You may also deactivate the hold-music audio by pressing the **FLASH** button.

**NOTE1:** If you hear a Low Volume audio during your conversation , say something to prevent full volume hold music activation, this can happen if you or your party are not talking to each other for about 7 seconds.

**NOTE2:** If for any reason the hold music is playing, do not panic, simply speak over the audio to stop it or press FLASH to stop it.

**C2:** If for some reason you are not able to voice activate or voice -deactivate, Hang up and set the switch to **C2** then try again following the above instructions.

**C3:** In this switch setting to **activate** the Hold music instantly press **FLASH** then Hold or just press the hold button and it will activate later (when the call has been on Hold at least 10-15 seconds) be sure to observe the requirements for voice activation by reading the operations in C1 or C2 setting above and the related Notes.

To **deactivate** hold music re-select that line and **speak over** the audio e.g. “*Hi I am Back*” or press the **FLASH** button. In C3 mode of operation the flash button is being used so be sure to read the examples related to Call waiting in page P4 if you have call waiting service or need to make 3 way callings etc.