

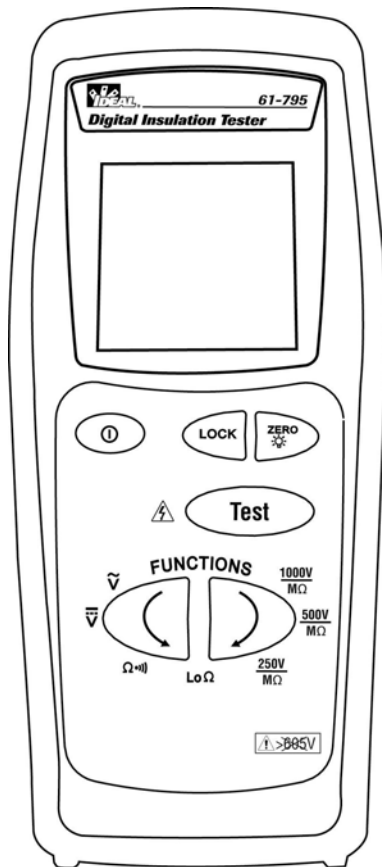

**IDEAL INDUSTRIES INC.
TECHNICAL MANUAL
MODEL: 61-795**

The Service Information provides the following:

- Precautions and safety information
- Specifications
- Performance test procedure
- Calibration and calibration adjustment procedure
- Basic maintenance (replacing the battery and fuses)



Form number: TM61795
Revision: 3. Date: June 2008

TABLE OF CONTENTS

Title	Page
Introduction	1
Precautions and Safety Information	1
Safety Information	1
Required Equipment	2
Performance Verification	3
Table 1 Performance Verification Model 61-795	3
Calibration	4/5
Table 2 Calibration Range Inputs Model 61-795	5
Replacing the Battery	5
Replacing Fuses	5
Circuit Board Drawing	6
Battery and Fuse Replacement Drawing	7

Introduction

 **Warning**

To avoid shock or injury, do not perform the verification tests or calibration procedures described in this manual unless you are qualified to do so.

The information provided in this document is for the use of qualified personnel only.

 **Caution**

The 61-795 contains parts that can be damaged by static discharge. Follow the standard practices for handling static sensitive devices.

*For additional information about IDEAL INDUSTRIES and its products, and services, visit IDEAL INDUSTRIES web site at:
www.idealindustries.com*

SAFETY

Review the following safety precautions to avoid injury and prevent damage to this product or any products connected to it. To avoid potential hazards, use the product only as specified.

It is recommended that you read through the Operation or User manual before starting. Not all Caution, Warning, or Danger precautions are listed in this manual.

 **CAUTION.**

These statements identify conditions or practices that could result in damage to the equipment or other property.

 **WARNING.**

These statements identify conditions or practices that could result in personal injury or loss of life.

Specific precautions

Use proper Fuse. To avoid fire hazard, use only the fuse type and rating specified for this product.

Do not operate without covers. To avoid personal injury, do not apply any voltage or current to the product without the covers in place.

Electric overload. Never apply a voltage to a connector on the product that is outside the range specified for that connector.

Avoid electric shock. To avoid injury or loss of life, do not connect or disconnect probes or test leads while they are connected to a voltage source.

Avoid electric shock. To avoid injury or loss of life, do not come in contact with tested material or probes while the Test Button is pressed. High Voltage potentials are present during Insulation Tests..

Do not operate in wet/damp conditions. To avoid electric shock, do not operate this product in wet or damp conditions.

Required Equipment

Required equipment is listed in Table B. If the recommended models are not available, equipment with equivalent specifications may be used. Only qualified personnel should perform repairs or servicing.

Table B. Required Equipment

Equipment	Required Characteristics	Recommended Model
Calibrator	<p>AC Voltage Range: 0-750V ac Accuracy: ±0.04% (Basic) Frequency Range: 10 ~ 500KHz Accuracy: ± 2%</p> <p>DC Voltage Range: 0-1000V dc Accuracy: ±0.006% (Basic)</p> <p>Current Range: 0 ~ 10A Accuracy: AC (45Hz to 65Hz): ±0.05% (Basic) DC: ± 0.008% (Basic)</p> <p>Frequency Source: 0.01Hz ~ 2.0000MHz Accuracy: ±0.0025%</p> <p>Amplitude: 0.5V p-p ~ 1.0V p-p (square wave) Accuracy: ± 5%(45Hz-1KHz)</p> <p>Ω range: 0.01 Ω ~ 330M Accuracy: ±0.007% (Basic)</p> <p>Capacitance Range: 1pF ~ 1.1mF Accuracy: ±0.19% (Basic)</p> <p>Temperature Range: -200°C ~ 1800°C Accuracy: ±0.1°C (Basic)</p>	Fluke 5500A Calibrator or equivalent

Required fixed resistors: 0Ω, 5Ω, 19Ω, 190Ω, 0.0MΩ, 1MΩ, 10MΩ, 100MΩ, 1000MΩ



Simulated Test leads: With a total resistance of < .1Ω ±10mΩ or .05Ω per simulated lead.

PERFORMANCE VERIFICATIONS

Perform the following analysis, if the meter conforms to the limits listed in Table 1 the meter is functioning correctly. If the meter does not conform to any of the listed limits, the calibration procedure must be performed.

Check the fuse as a BBS, 1A/600V, 10.4*35 (0.41x1.38 inch) UL/CSA, interrupting rating 10kA.
Check case, leads, display, etc, for any defects.

Table 1 Performance Verification: Model 61-795

Function Setting /Range	Apply	Reading	Specification
DCV	550V DC	547.2 to 552.8	[±0.5% ±1 digits]
ACV	550V AC	545.2 to 554.8	[±0.8% ±4 digits]
Continuity Ω / 	<30 Ω	Buzzer sounds	Not specified
Resistance:			
LO Ω	Simulated leads	.08 to .12	[±0.02 Ω + 0.05 per lead]
LO Ω	0 Ω	-0.03 to +0.03	[±0.03 Ω]
LO Ω	5 Ω	4.87 to 5.13	[±2.0% ±3 digits]
LO Ω	19 Ω	18.59 to 19.41	[±2.0% ±3 digits]
Ω / 	190 Ω	185.9 to 194.1	[±2.0% ±3 digits]
LO Ω	10 Ω	20.2mA to 25.8mA	Source check
LO Ω	1 Ω	202mA to 258mA	Source check
Insulation Resistance:			
M Ω , 250V	10M Ω	250 to 275Vdc	Source Check
M Ω , 500V	10M Ω	500 to 550Vdc	Source Check
M Ω 1000V	10M Ω	1000 to 1100Vdc	Source Check
M Ω , 250V	0 Ω	0.001 to 0.010	±10 digits
	100k Ω	0.090 to 0.110	±10 digits
	1M Ω	0.975 to 1.025	[±2.0% ±5 digits]
	10M Ω	9.75 to 10.25	[±2.0% ±5 digits]
	100M Ω	94.5 to 105.5	[±5.0% ±5 digits]
M Ω , 500V	100k Ω	0.085 to 0.115	±15 digits
	1M Ω	0.975 to 1.025	[±2.0% ±5 digits]
	10M Ω	9.75 to 10.25	[±2.0% ±5 digits]
	100M Ω	97.5 to 102.5	[±2.0% ±5 digits]
	1000M Ω	945 to 1055	[±5.0% ±5 digits]
M Ω , 1000V	100k Ω	0.085 to 0.015	±15 digits
	1M Ω	0.975 to 1.025	[±2.0% ±5 digits]
	10M Ω	9.75 to 10.25	[±2.0% ±5 digits]
	100M Ω	97.5 to 102.5	[±2.0% ±5 digits]
	1000M Ω	965 to 1035	[±3.0% ±5 digits]
M Ω , 500V	500K Ω	<500V	Source Check
Check on each Voltage range	0M Ω	<3.0mA	Source Check

CALIBRATION

Calibration Preparation

Required Equipment

The class of calibrator or equipment should have an accuracy that exceeds, by an expectable ratio, the accuracy of the instrument under test.

Required fixed resistors: 0 Ω , 5 Ω , 19 Ω , 190 Ω , 0.0M Ω , 1M Ω , 10M Ω , 100M Ω , 1000M Ω

Simulated Test leads. With a total resistance of < .1 Ω \pm 10m Ω or .05 Ω per simulated lead.

Calibration Procedure

It is recommended that all IDEAL meters undergo the following calibration procedure on an annual basis.

Calibration





1. Press the  key to switch off the instrument.
2. Remove test leads from the input terminals.
3. Remove hood and battery compartment cover by using a screwdriver. (*Refer to Figure 2*)
4. Loosen the screws from the case bottom. Remove the case bottom.
5. Short JP1, then replace the case bottom and battery compartment cover. (*Refer to Figure 1*)
6. Press the  key to turn on the instrument. The LCD displays the version of the software.
7. Push the "TEST" key to enter the calibration mode.
8. Press the  key to select the range to calibrate.
9. Input the range standard value as listed in Table 2. Push the "TEST" key for more than 2 seconds. The LCD will display the A/D reading value.
10. Push the "TEST" key to save the range. Calibration is complete for that range.
11. If you want to calibrate the other ranges, repeat steps 8 - 10.
12. When complete, exit the calibration mode. Press the  key to switch off the instrument.
13. Remove the case bottom and remove the short on JP1. (*Refer to Figure 1*)
14. Replace the case bottom and battery compartment cover, pressing to close it, and secure with screw.
15. Install the hood.

Table 2 Calibration Range Inputs: Model 61-795

Range	Function	Input the calibrator standard value
1	DCV	DC600.0V
2	ACV	AC600.0V
3	$\Omega \bullet \bullet \bullet$	190.0 Ω
4	$\Omega \bullet \bullet$	0.00 Ω
5	LO Ω	19.00 Ω
6	LO Ω	0.00 Ω
7	LO Ω	5.00 Ω
8	LO Ω	0.00 Ω
9	250V/M Ω	1000M Ω
10	250V/M Ω	100.0M Ω
11	250V/M Ω	10.00M Ω
12	250V/M Ω	1.000M Ω
13	250V/M Ω	0.000M Ω
14	500V/M Ω	1000M Ω
15	500V/M Ω	100.0M Ω
16	500V/M Ω	10.00M Ω
16	500V/M Ω	1.000M Ω
18	500V/M Ω	0.000M Ω
19	1000V/M Ω	1000M Ω
20	1000V/M Ω	100.0M Ω
21	1000V/M Ω	10.00M Ω
22	1000V/M Ω	1.000M Ω
23	1000V/M Ω	0.000M Ω

Battery Replacement (Refer to Figure 2)

1. Disconnect the test leads from any circuit under test.
2. Press the  key to switch off the instrument.
3. Remove the hood and battery compartment cover by using a screwdriver.
4. Remove the batteries replacing them with new ones all of the same type (1.5×6 NEDA 15F IEC R6 JIS UM-3) (Alkaline batteries are recommended.) making sure of polarity while installing.
5. Install bottom case cover and secure with screws.
6. Install the hood.

Replacing Fuse (Refer to Figure 2)

1. Disconnect the test leads from any circuit under test.
2. Press the  key to switch off the instrument.
3. Remove the hood and battery compartment cover by using a screwdriver.
4. Loosen the screws from the case bottom. Remove the case bottom.
5. Remove input cover using a screwdriver.
6. Check the fuse with a digital multimeter with a source current < 10mA in low resistance range.
(Replace fuse with a BBS 1A/600V, 10.3*38 (1.5x0.41 inch) UL/CSA, interrupting rating 10kA.)
7. Install input cover and secure with screw.
8. Replace the case bottom and secure with screw.
9. Replace the battery compartment cover, pressing to close it, and secure with screw.
10. Install the hood.

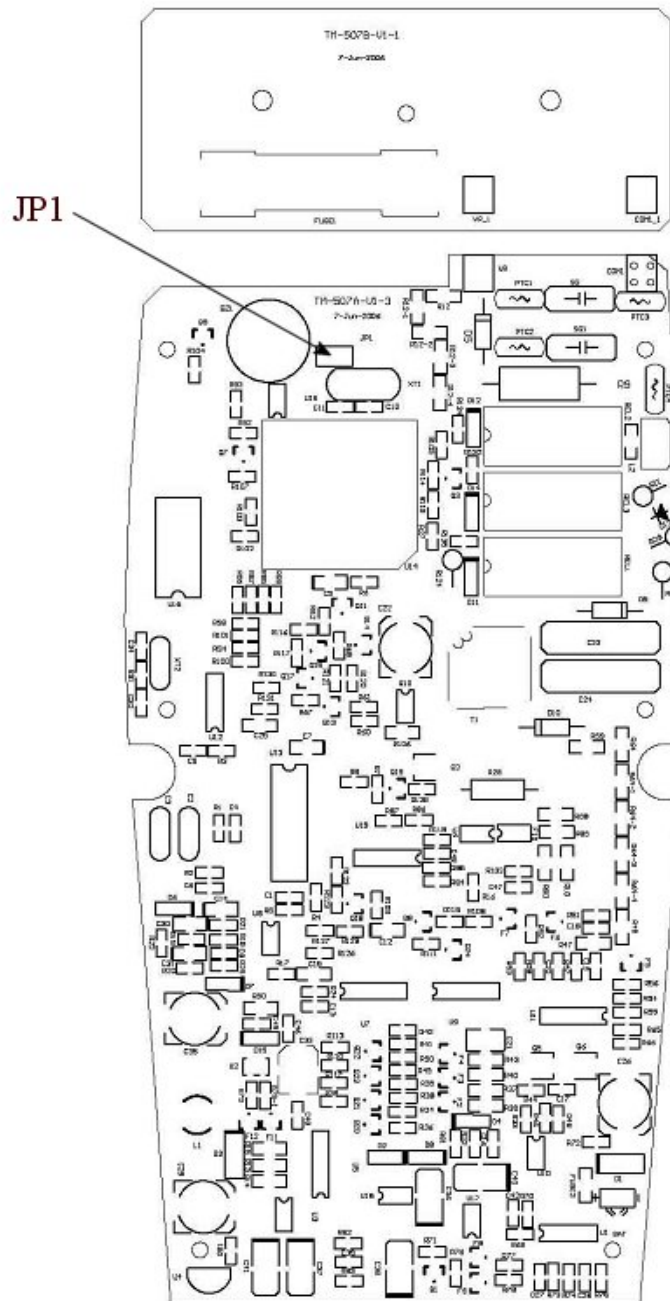

Figure 1

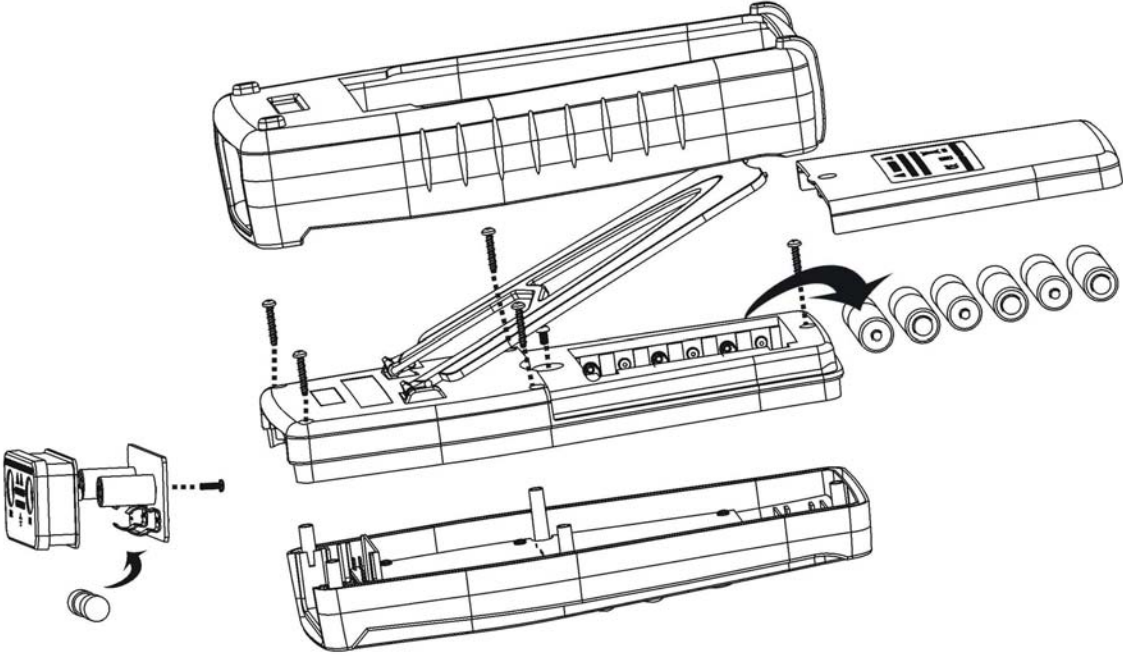

Figure 2

Test Equipment Depot
99 Washington Street
Melrose, MA 02176
Phone 781-665-1400
Toll Free 1-800-517-8431

- [Visit us at www.TestEquipmentDepot.com](http://www.TestEquipmentDepot.com)
- [Back to the Ideal 61795 Product Info Page](#)

Test Equipment Depot - 800.517.8431 - 99 Washington Street Melrose, MA 02176
FAX 781.665.0780 - TestEquipmentDepot.com