



Test Equipment
Depot
1-800-517-8431

#61-764
#61-766
#61-768

600A Clamp Meters w/TightSight™ Display

Instruction Manual

99 Washington Street
Melrose, MA 02176
Fax 781-665-0780
TestEquipmentDepot.com

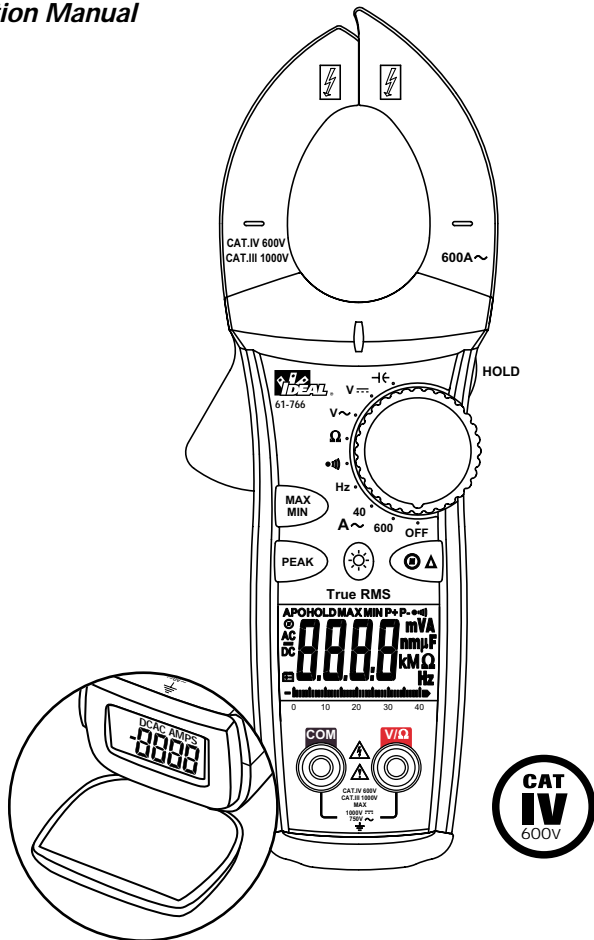

TightSight™ Display





Read First: Safety Information

Understand and follow operating instructions carefully. Use the meter only as specified in this manual; otherwise, the protection provided by the meter may be impaired.



WARNING

To avoid possible electric shock, personal injury or death, follow these guidelines:

- Do not use if meter appears damaged. Visually inspect the meter to ensure case is not cracked and back case is securely in place.
- Inspect and replace leads if insulation is damaged, metal is exposed, or probes are cracked. Pay particular attention to the insulation surrounding the connectors.
- Do not use meter if it operates abnormally as protection may be impaired.
- Do not use during electrical storms or in wet weather.
- Do not use around explosive gas, dust, or vapor.
- Do not apply more than the rated voltage to the meter.
- Do not use without the battery and the back case properly installed.
- Remove the test leads from the circuit prior to removing battery cap.
- Do not attempt to repair this unit as it has no user-serviceable parts.

CAUTION

To protect yourself, think "Safety First":

- Voltages exceeding 30VAC or 60VDC pose a shock hazard so use caution.
- Use appropriate personal protective equipment such as safety glasses, face shields, insulating gloves, insulating boots, and/or insulating mats.
- Before each use:
 - Perform a continuity test by touching the test leads together to verify the functionality of the battery and test leads.
 - Use the 3 Point Safety Method. (1) Verify meter operation by measuring a known voltage. (2) Apply meter to circuit under test. (3) Return to the known live voltage again to ensure proper operation.
- Never ground yourself when taking electrical measurements.
- Connect the black common lead to ground or neutral before applying the red test lead to potential voltage. Disconnect the red test lead from the voltage first.
- Always work with a partner.
- When using the probes, keep fingers as far behind the probe tips as possible.

760 Series Common Features:

- Auto/manual ranging clamp meter
- TightSight™ bottom display
- Visual and audible indication when voltage is present even when the meter is set on the wrong function for enhanced safety
- Measures 600 AAC Current
- Measures AC/DC Voltage & Resistance
- Audible continuity
- Bright, bold backlight
- Large numbers and symbols displayed
- Peak max/min, max/min, data hold
- Selectable Auto power off and low battery indicator
- Tapered jaws for reaching into tight spaces
- Hook tip for easier wire separation
- Protective rubber boot
- Electronic overload protection on all ranges
- Cat IV-600V/Cat III-1000V
- 61-764 model is averaging sensing, rms calibrated
- 61-766 model is true rms sensing, measures capacitance, frequency and lower currents with a 40 AAC range for troubleshooting motors and adjustable speed drives
- 61-768 model is true rms sensing and measures DC current

Features

1. Tapered jaws w/hook tip
2. Lever
3. Function Dial
4. Main Display (LCD)
5. Volts and resistance (V-Ω) input terminal
6. Common (COM) input terminal
7. TightSight™ bottom display
8. Protective rubber boot
9. Measuring Functions
10. High Voltage (Hi-V) warning
11. Data Hold
12. Max/min
13. Peak max/min
14. Backlight
15. Range (⊙)
16. Relative mode (Δ)

Symbols on the Unit

- ⚠ Warning - read the instruction manual
- Cat IV - 600V Safety category
- Cat III - 1000V Safety category

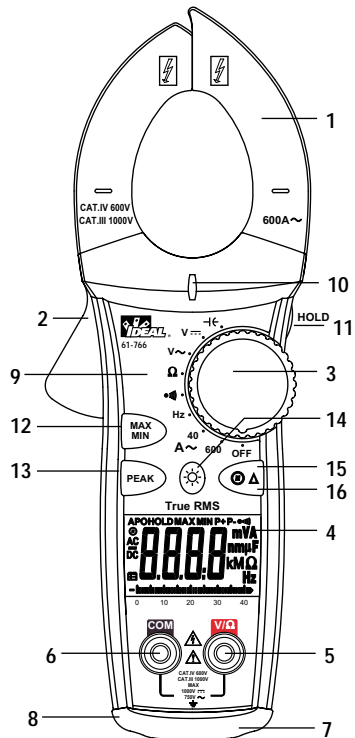

Main Display Icons

- 15. 4000 count display
- 16. AC measurement
- 17. DC measurement
- 18. Polarity indicator for DC
- 19. Range (⊙)
- 20. Auto Power Off (APO)
- 21. Data Hold
- 22. Max/min
- 23. Peak max/min
- 24. Audible continuity
- 25. Volts
- 26. Amps
- 27. Farads
- 28. Ohms
- 29. Hertz
- 30. Units of measure
- 31. Analog bar graph
- 32. Low battery indicator
- 33. Relative (Δ)

Main Display

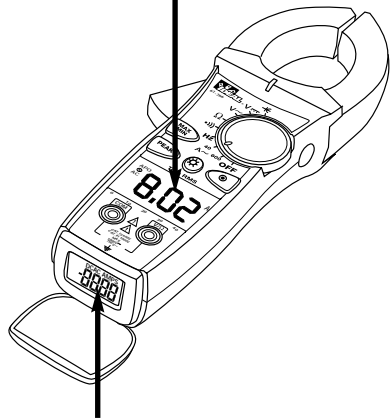
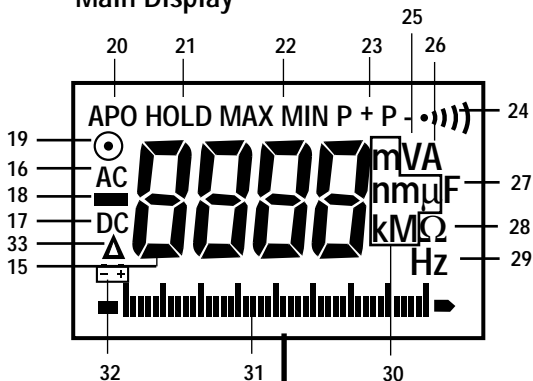

TightSight™ Bottom Display

TightSight™ Display Icons

- 34. 4000 count display
- 35. Polarity indicator for DC
- 36. DC measurement
- 37. AC measurement
- 38. Amps

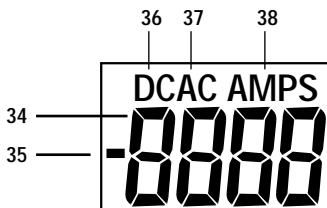

Note: Only AC/DC amps units of measure are displayed in the TightSight™ display since primary use is for viewing current measurements in tight locations. The display will show numerical values only for other functions. The main display is to be used to view units of measure for all other functions.

OPERATION:

High Voltage Warning (HI-V)

The meter beeps and lights an LED when > 30V AC/DC voltage is present through the test leads of the meter. This enhanced safety feature alerts the user that dangerous voltage is present across the leads even if the meter is set on an incorrect function or range.

Note: This features does not work through the clamp head as the clamp is intended to only measure current.

Auto/Manual Ranging Mode (⊙)

The meter defaults to autoranging mode when powered on. In this mode, the meter automatically selects the best range to display the measurement. By pressing the Range (⊙) button on the meter, the manual range mode will override the auto-ranging feature of the meter. A (⊙) appears in the upper left side of the display. Continue pressing the Range button until the desired range is obtained. Use this mode to lock in a specific range for repeated measurements. To return to the autoranging mode, either depress the Range button for greater than 1 second or turn the meter off and then back on again.

Peak Max/Min Feature

Peak function captures peak voltage in the VAC function and peak current in the AAC function. Both P+ and P- are have 1 ms capture time. Set the meter to the desired function, press the "PEAK" button and apply the setup to the circuit. The P+ will be displayed. Press the "PEAK" button again to display the P-. Depress the peak button for >2 sec. to exit the peak feature.

Note: If more accurate peak measurement is required, then calibration should be performed. Depress the Peak button for >2 sec. until "CAL" appears in the display. The meter self-calibrates to $\pm 3\% + 60$ digits accuracy. (400m/4VAC/40AAC ranges unspecified)

Max/Min Feature

The Max records the maximum value measured over time while Min captures the minimum value measured over time. Press the Max/Min button to activate this feature and to toggle between Max, Min and Maxmin. "MAXMIN" displays the real time reading while still capturing max and min values over time. Depressing the max/min button for >2 sec. exits the mode.

Note: To record max/min values over a time period >30 min, the Auto Power Off (APO) feature must be defeated.

Data Hold Feature

Press the Hold button on the side of the meter to toggle in and out of the data hold mode. "HOLD" appears in the upper left of the meter display when data hold is active. Use the data hold feature to lock a measurement reading on the display. Press the Hold button again to unlock the display and obtain a real-time reading.

Relative Mode (Δ) (61-768 model only)

This mode is used to zero out the display before measuring DC current. Press the " Δ " button to subtract out the non-zero number. Then, measure the DC amps. Pressing the " Δ " button again causes the " Δ " to flash and the original offset number to be displayed. Depress the " Δ " button for >2 sec. to exit this mode.

Selectable Auto Power Off (APO) Feature

The meter automatically powers itself down after about 30 minutes of no use. Press any button, and the meter will wake up and display the last reading taken before power down. This feature can be overridden by holding the Range (\odot) button while turning the function switch from Off to any other position. When APO is defeated, the "APO" will be removed from the display. Turning the meter off will restore the APO default.

Backlight

Press the \odot button in the middle of the meter to turn the backlight on and off. The green backlight will remain lit for about 4.5 minutes before it automatically turns off to conserve battery power. Also, the TightSight™ bottom display only lights while the meter is in the Amp function to minimize battery drain.

Note: Backlight consumes 4x the battery power.

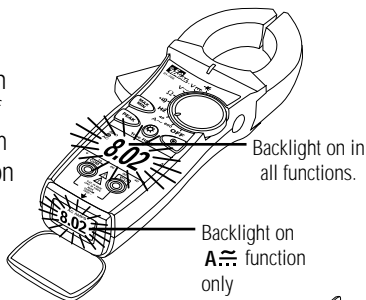

Measuring AC Current (Amps):

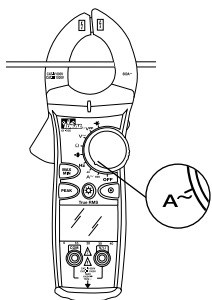

CORRECT
Single
Conductor
only

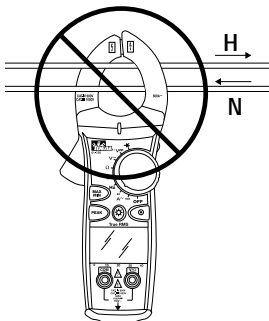

INCORRECT
Currents
cancel

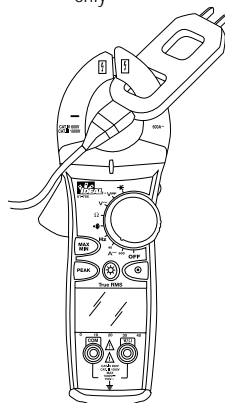

CORRECT
Use with
line splitter

Note: 61-768 model also measures DC Current.

Measuring Voltage:

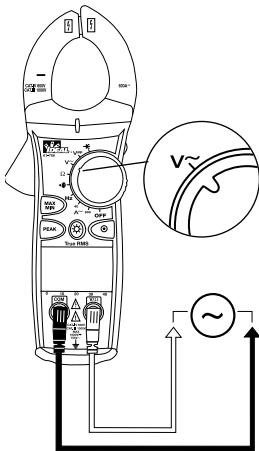

AC Voltage

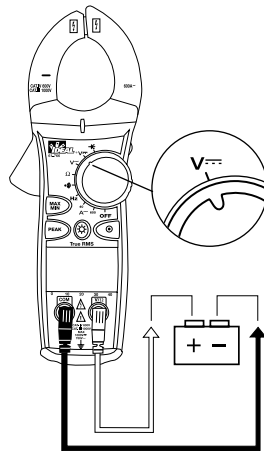

DC Voltage

Measuring Resistance (Ohms):

- Verify the circuit is de-energized to obtain accurate measurements.

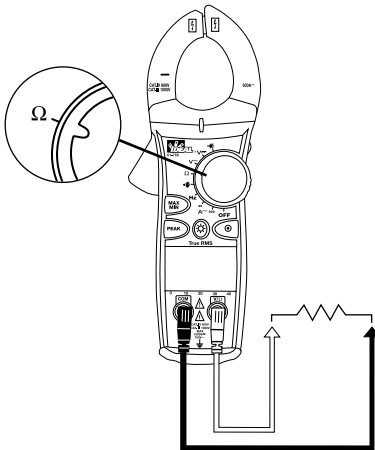

Verifying Continuity (•••••) :

- Verify the circuit is de-energized.
- The meter will sense the level of resistance and beep if the resistance is less than 35Ω to confirm that continuity is present.

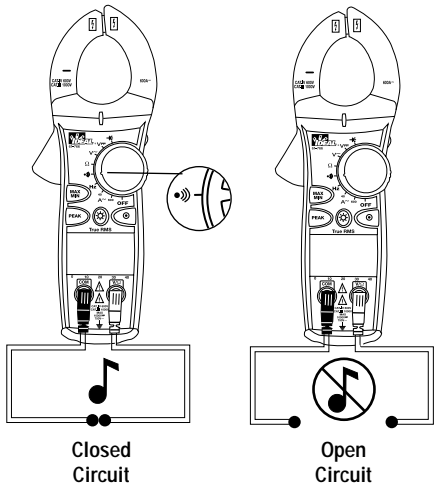

Capacitance (61-766):

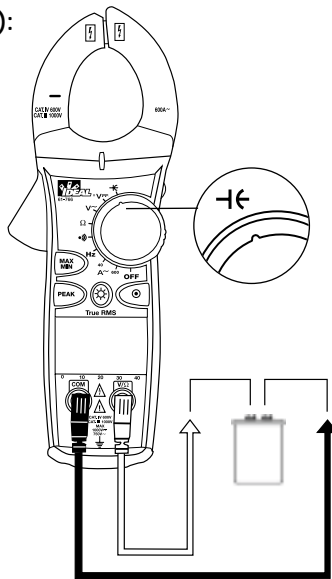

Frequency (61-766):

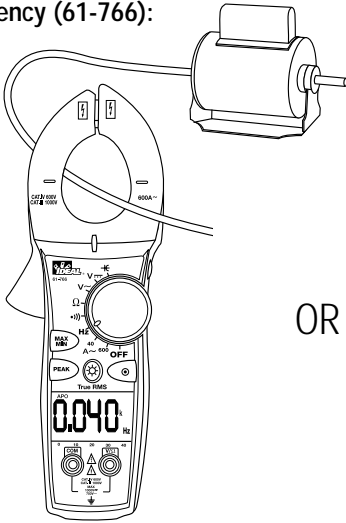

Current Mode

OR

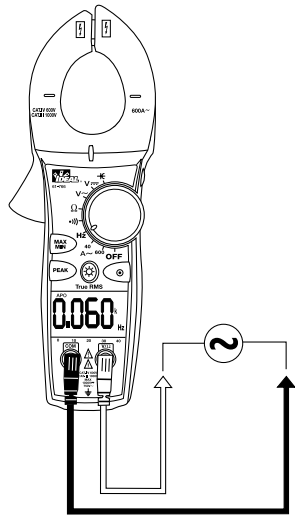

Voltage Mode

Battery Replacement:

- Ensure test leads are disconnected from circuit or components.
- Remove test leads from input jacks on meter.
- Remove the two screws from the battery cap.
- Remove the battery cap.
- Replace battery with a new 9V battery.
- Assemble the battery cap to the meter and re-tighten the screws.

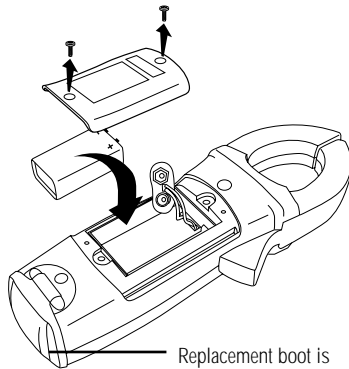

Replacement boot is available.

Maintenance:

Clean the case with a damp cloth and mild detergent. Do not use abrasives or solvents.

Service and Replacement Parts:

This unit has no user-serviceable parts.

For replacement parts or to inquire about service information contact IDEAL INDUSTRIES, INC. at 1-877-201-9005 or visit our website www.testersandmeters.com.

Specifications:

Displays:	3-3/4 digit LCD with 4000 counts for both displays
Backlight:	Green illumination with auto-off after 4.5 minutes
Analog Bargraph:	41 segment LCD with measurements of 20 times per second
Polarity:	Automatic, positive implied, negative (-) polarity indication.
Overrange:	"OL" indication is displayed.
Zero:	Automatic
Measure Rate:	Samples 2 times per second, nominal.
Auto Power Off:	Approximately after 30 minutes of non-use.
Battery Life:	400 hours continuous with Alkaline (61-764) 200 hours continuous with Alkaline (61-766) 150 hours continuous with Alkaline (61-768)
Low Battery Indication:	The "  " is displayed when battery voltage drops below operating level.
Power Supply:	(1) 9V battery (NEDA 1604, JIS 006P, IEC 6F22) Includes an isolated battery compartment.
Accuracy:	Stated accuracy at 23°C ±5°C, <75% R.H.
Temperature	0.1 x (specified accuracy) per °C,
Coefficient:	(0°C to 18°C, 28°C to 50°C).
Altitude:	6561.7 ft. (2000m)
Operating Environment:	32°F to 122°F (0°C to 50°C) at < 70% R.H.
Storage Environment:	-4°F to 140°F (-20°C to 60°C) at < 80% R.H. with battery removed from meter
Jaw Opening:	Accepts a 1.42" (36mm) conductor
Dimensions:	8.7"H x 3.1"W x 1.8"D (222mmH x 80mmW x 45.5mmD)
Weight:	12.3 oz (350g) including battery
Accessories included:	Carrying Case, Test Leads with alligator clip, (1) 9V battery, operating instructions.
Safety:	Complies with EN 61010-1, EN 61010-2-032, UL 61010-1, IEC 61010-2-032, IEC61010-031 specifications, Cat IV-600V/Cat III-1000V.



N12966



Double Insulation

Instrument has been evaluated and complies with insulation category IV (overvoltage category IV). Pollution degree 2 in accordance with IEC-644. Indoor use.

Ranges & Accuracies:

AC Converter: 61-764 model is averaging sensing, rms calibrated
61-766, 61-768 models are true rms sensing.

Accuracy: Accuracy is specified as +/- (a percentage of the reading + a fixed amount) at 23°C±5°C (73.4°F ± 9°F), less than 75% relative humidity.

Temperature Coefficient: 0.1 times the applicable accuracy specification per degree C from 0°C to 18°C and 28°C to 50°C (32°F to 64°F and 82°F to 122°F)

Function	Range and Resolution	Accuracy			Overload Protection
		61-764	61-766	61-768	
AC Current*	40.00A (50-60Hz)	N/A	1.7% + 10	N/A	600 AAC
	40.00A (60-400Hz)	N/A	3.0% + 10	N/A	
	400.0/600A (50-60Hz)	1.7% + 6	1.7% + 10		
	400.0/600A (60-400Hz)	3.0% + 6	3.0% + 10		
DC Current	400.0/600A (0-400A)	N/A	N/A	1.5% + 5	600 ADC
	400.0/600A (400-600A)	N/A	N/A	2.0% + 5	
AC Voltage	400.0m (50-60Hz)	1.2% + 5	1.2% + 8		1000VDC or 750VAC rms
	4.000/40.00/400.0V (50-500 Hz)	1.2% + 5	1.2% + 8		
	750V (50-500Hz)	1.5% + 5	1.5% + 8		
DC Voltage	400.0m/4.000/40.00/400.0/1000V	0.5% + 2			1000VDC or 750 VAC rms
Resistance	400.0/4.000k/40.00k/400.0kΩ	1.0% + 4			600 VDC or AC rms
	4.000MΩ	5.0% + 4		9.0% + 4	
	40.00MΩ (specified to 10MΩ)	12.0% + 5		20.0% + 5	
Capacitance	4.000μF	N/A	3.0% + 10	N/A	600 VDC or AC rms
	40.00μ/400.0μ F	N/A	3.0% + 5	N/A	
	4.000mF	N/A	5.0% + 20	N/A	
Frequency**	0.020k to 0.400k Hz	N/A	0.1% + 3	N/A	600 AAC or 600 VDC or AC rms
	Sensitivity is 20-100Hz (≥ 5A) 100-400 Hz (≥ 10A)				
Continuity	Audible indication < 35Ω	•	•	•	600 VDC or AC rms
	Response time: 500ms	•	•	•	

*Accuracy stated for crest factor ≤ 3 at full scale and ≤ 6 at half scale

**Frequency can be measured through clamp head or with use of test leads.

Input impedance: 400mV: >50MΩ; 4V: 10MΩ; 40V- 1000V: 9.1MΩ

Warranty Statement:

This tester is warranted to the original purchaser against defects in material and workmanship for the lifetime of the product. During this warranty period, IDEAL INDUSTRIES, INC. will, at its option, replace or repair the defective unit, subject to verification of the defect or malfunction. This warranty does not apply to defects resulting from abuse, neglect, accident, unauthorized repair, alteration, or unreasonable use of the instrument.

Any implied warranties arising out of the sale of an IDEAL product, including but not limited to implied warranties of merchantability and fitness for a particular purpose, are limited to the above. The manufacturer shall not be liable for loss of use of the instrument or other incidental or consequential damages, expenses, or economic loss, or for any claim or claims for such damage, expenses or economic loss.

State laws vary, so the above limitations or exclusions may not apply to you. This warranty gives you specific legal rights, and you may also have other rights which vary from state to state.