

ENGLISH

**Test Equipment
Depot**
1-800-517-8431

99 Washington Street
Melrose, MA 02176
Phone 781-665-1400
Toll Free 1-800-517-8431

HAMEG[®]
Instruments



Visit us at www.TestEquipmentDepot.com

HM8035

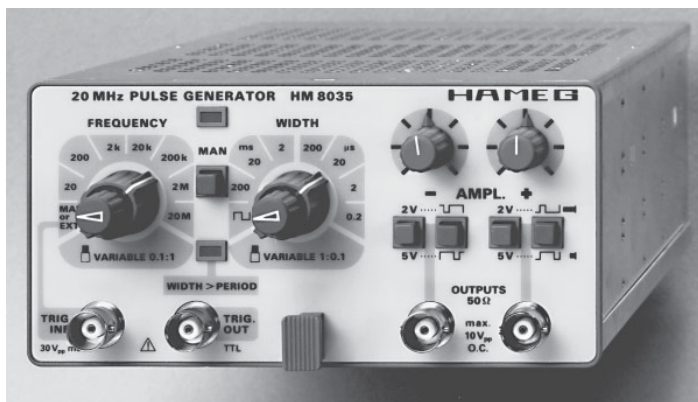

MANUAL • HANDBUCH • MANUEL

General information regarding the CE marking

HAMEG instruments fulfill the regulations of the EMC directive. The conformity test made by HAMEG is based on the actual generic- and product standards. In cases where different limit values are applicable, HAMEG applies the severer standard. For emission the limits for residential, commercial and light industry are applied. Regarding the immunity (susceptibility) the limits for industrial environment have been used.

The measuring- and data lines of the instrument have much influence on emission and immunity and therefore on meeting the acceptance limits. For different applications the lines and/or cables used may be different. For measurement operation the following hints and conditions regarding emission and immunity should be observed:

1. Data cables

For the connection between instruments resp. their interfaces and external devices, (computer, printer etc.) sufficiently screened cables must be used. Without a special instruction in the manual for a reduced cable length, the maximum cable length of a dataline must be less than 3 meters long. If an interface has several connectors only one connector must have a connection to a cable.

Basically interconnections must have a double screening. For IEEE-bus purposes the double screened cables HZ72S and HZ72L from HAMEG are suitable.

2. Signal cables

Basically test leads for signal interconnection between test point and instrument should be as short as possible. Without instruction in the manual for a shorter length, signal lines must be less than 3 meters long.

Signal lines must be screened (coaxial cable - RG58/U). A proper ground connection is required. In combination with signal generators double screened cables (RG223/U, RG214/U) must be used.

3. Influence on measuring instruments.

Under the presence of strong high frequency electric or magnetic fields, even with careful setup of the measuring equipment an influence of such signals is unavoidable.

This will not cause damage or put the instrument out of operation. Small deviations of the measuring value (reading) exceeding the instruments specifications may result from such conditions in individual cases.

KONFORMITÄTSERLÄRUNG
DECLARATION OF CONFORMITY
DECLARATION DE CONFORMITE



HAMEG[®]
Instruments

Name und Adresse des Herstellers
Manufacturer's name and address
Nom et adresse du fabricant

HAMEG GmbH
Kelsterbacherstraße 15-19
D - 60528 Frankfurt

HAMEG S.a.r.l.
5, av de la République
F - 94800 Villejuif

Die HAMEG GmbH / HAMEG S.a.r.l. bescheinigt die Konformität für das Produkt
The HAMEG GmbH / HAMEG S.a.r.l. herewith declares conformity of the product
HAMEG GmbH / HAMEG S.a.r.l. déclare la conformité du produit

Bezeichnung / Product name / Designation: L-C Meter / LC-METRE / Medidor LC

Typ / Type / Type: **HM8035**

mit / with / avec: **HM8001-2**

Optionen / Options / Options: -

mit den folgenden Bestimmungen / with applicable regulations / avec les directives suivantes

EMV Richtlinie 89/336/EWG ergänzt durch 91/263/EWG, 92/31/EWG
EMC Directive 89/336/EEC amended by 91/263/EWG, 92/31/EEC
Directive EMC 89/336/CEE amendée par 91/263/EWG, 92/31/CEE

Niederspannungsrichtlinie 73/23/EWG ergänzt durch 93/68/EWG
Low-Voltage Equipment Directive 73/23/EEC amended by 93/68/EEC
Directive des équipements basse tension 73/23/CEE amendée par 93/68/CEE

Angewendete harmonisierte Normen / Harmonized standards applied / Normes harmonisées utilisées

Sicherheit / Safety / Sécurité

EN 61010-1: 1993 / IEC (CEI) 1010-1: 1990 A 1: 1992 / VDE 0411: 1994
Überspannungskategorie / Overvoltage category / Catégorie de surtension: II
Verschmutzungsgrad / Degree of pollution / Degré de pollution: 2

Elektromagnetische Verträglichkeit / Electromagnetic compatibility / Compatibilité électromagnétique

EN 50082-2: 1995 / VDE 0839 T82-2
ENV 50140: 1993 / IEC (CEI) 1004-4-3: 1995 / VDE 0847 T3
ENV 50141: 1993 / IEC (CEI) 1000-4-6 / VDE 0843 / 6
EN 61000-4-2: 1995 / IEC (CEI) 1000-4-2: 1995 / VDE 0847 T4-2: Prüfschärfe / Level / Niveau = 2

EN 61000-4-4: 1995 / IEC (CEI) 1000-4-4: 1995 / VDE 0847 T4-4: Prüfschärfe / Level / Niveau = 3

EN 50081-1: 1992 / EN 55011: 1991 / CISPR11: 1991 / VDE0875 T11: 1992

Gruppe / group / groupe = 1, Klasse / Class / Classe = B

Datum /Date /Date
20.09.1995

Unterschrift / Signature / Signatur

E. Baumgartner
Technical Manager
Directeur Technique

Specification

(Reference Temperature: 23°C ± 1°C)

Operating Modes:

Internal, external or manual triggering

Frequency Range: 2Hz to 20MHz

in 7 decade steps
Variable Control > 10:1

Pulse Duration: 20ns to 200ms

in 7 decade steps
Variable Control > 10:1

Jitter: ≤ ± 0.1%

Symmetric Square Wave:

Pulse duty factor 50% ± 10ns up to 2MHz,
50% ± 5% ± 10ns from 2MHz to 20MHz

Jitter: ≤ ± 0.1%

Single Pulse

Pulse Duration: ≤ 20ns to ≥ 200ms

Pulse Characteristic

Risetime/Falltime: ≤ 3ns (10% to 90%)

Overshoot: ≤ 5% of pulse amplitude

Top Ripple: ≤ ± 2% of pulse amplitude
(10ns after pulse step)

Preshoot: ≤ ± 2% of pulse amplitude

Dual-Outputs

+ Amplitude: max. + 5V into 50Ω to gnd
variable from + 2V to + 5V

- Amplitude: max. - 5V into 50Ω to gnd
variable from - 2V to - 5V

Attenuators: 1:2.5 (- 8dB)
(variable from ± 0.8V to ± 5V)

Output Impedance: 50Ω (both outputs)

External Trigger Input:

Pulse Repetition Frequency: 0 to 20MHz

Pulse Duration: 20ns min.

Trigger Delay: approx. 20ns

Trigger Level: Sinewave > 1V_p or
TTL compatible square wave > + 1V

Max. Input Voltage: 30V_{pp}, Fan in - 1

Trigger Output (short-circuit-proof)

Amplitude: 0/+ 1.9V into 50Ω, 0/< + 4V
open circuit, TTL compatible; fan-out: 5

Risetime/Falltime: approx. 10ns

Aberration:

approx. ± 10% of pulse amplitude

Pulse Duty Cycle:

identical to non-inverted signal

Delay: approx. 10ns, leading

General Information:

Operating conditions: + 10°C to + 40°C
max. relative humidity: 80%

Supply: (from HM8001): +5V/250mA
+20V/260mA; 20V/270mA
(Σ 11.9W)

Dimensions (mm): (without multipoint connector)

W 135, H 68, D 228mm

Weight: approx. 0.75kg

Subject to change without notice

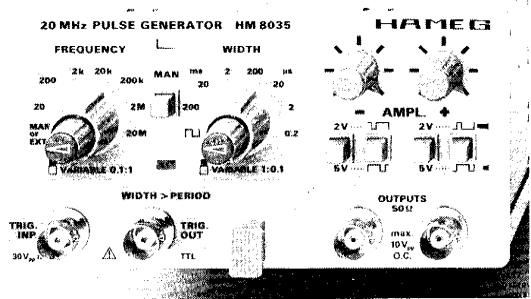

Pulse Generator HM 8035

- Frequency Range 2Hz to 20MHz
- Pulse Duration 20ns to 200ms
- 2 Separate Outputs (+ / -)
- Single Pulse Capability
- Indicator WIDTH > PERIOD

The **HM 8035** Pulse Generator is an extremely **versatile 20MHz signal source** suitable for analog, digital and logic applications in laboratory, production or maintenance environments. Key features of this module are its wide range of variable pulse frequencies and pulse durations, its constant **fast rise and decay time (less than 3ns)**, a calibrated position for squarewave output with 1:1 duty factor, and normal or **complementary dual outputs**. The **HM 8035** has manual or external trigger capability, the latter using TTL-pulses or sinewave signals in all ranges for waveshaping.

A built-in **error LED** indicates when pulse width is greater than the pulse period. Output amplitudes are variable providing a maximum of **5 volts into 50 ohms** or 10 volts, open circuit, positive or negative polarity relative to ground. All outputs are **short-circuit-proof**. The impressive performance, **compact design** and **ease of operation** of the **HM 8035** make it well suited for a large variety of analog and digital applications, such as testing logic interfacing, differential input amplifiers and multiplexers, wideband amplifiers, or simulation of line drivers, opposite-phase clocks and switching cycles.

Optional Accessories

HZ33, HZ34: 50Ω test cable BNC-BNC.

HZ22: 50Ω through-termination.

General information

The operator should not neglect to carefully read the following instructions and those of the mainframe HM8001, to avoid any operating errors and to be fully acquainted with the module when later in use.

After unpacking the module, check for any mechanical damage or loose parts inside. Should there be any transportation damage, inform the supplier immediately and do not put the module into operation.

This plug-in module is primarily intended for use in conjunction with the Mainframe HM8001. When incorporating it into other systems, the module should only be operated with the specified supply voltages.

Safety

Every module is manufactured and tested for use only with the mainframe HM8001 according to IEC 348 Part 1 and 1a (Safety requirements for electronic test and measurement equipment). All case and chassis parts are connected to the safety earth conductor. Corresponding to Safety Class 1 regulations (three-conductor AC power cable). Without an isolating transformer, the instrument's power cable must be plugged into an approved three-contact electrical outlet, which meets International Electrotechnical Commission (IEC) safety standards.

Warning!

Any interruption of the protective conductor inside or outside the instrument or disconnection of the protective earth terminal is likely to make the instrument dangerous. Intentional interruption is prohibited.

The instrument must be disconnected and secured against unintentional operation if there is any suggestion that safe operation is not possible. This may occur

- if the instrument has visible damage,
- if the instrument has loose parts,
- if the instrument does not function,
- after long storage under unfavourable circumstances (e.g. outdoors or in moist environments),
- after excessive transportation stress (e.g. in poor packaging).

When removing or replacing the metal case, the instrument must be completely disconnected from the mains supply. If any measurement or calibration procedures are unavoidable on the opened up instrument, these must only be carried out by qualified personnel acquainted with the danger involved.

Symbols As Marked on Equipment



DANGER - High voltage



Protective ground (earth) terminal



ATTENTION refer to manual

Operating conditions

The ambient temperature range during operation should be between +10°C and +40°C and should not exceed -40°C or +70°C during transport or storage. The operational position is optional, however, the ventilation holes on the HM8001 and on the plug-in modules must not be obstructed.

Warranty

Before being shipped, each plug-in module must pass a 24 hour quality control test.

Provided the instrument has not undergone any modifications Hameg warrants that all products of its own manufacture conform to Hameg specifications and are free from defects in material and workmanship when used under normal operating conditions and with the service conditions for which they were furnished.

The obligation of HAMEG hereunder shall expire two (2) years after delivery and is limited to repairing, or at its option, replacing without charge, any such product which in Hameg's sole opinion proves to be defective with the scope of this warranty.

This is Hameg's sole warranty with respect to the products delivered hereunder. No statement, representation, agreement or understanding, oral or written, made by an agent, distributor, representative or employee of, which is not contained in this warranty will be binding upon Hameg, unless made in writing and executed by an authorized Hameg employee. Hameg makes no other warranty of any kind whatsoever, expressed or implied, and all implied warranties of merchantability and fitness for a particular use which exceed the aforesaid obligation are hereby disclaimed by Hameg be liable to buyer, in contract or in tort, for any special, indirect, incidental or consequential damages, expenses, losses or delays however caused.

In case of any complaint, attach a tag to the instrument with a description of the fault observed. Please supply name and department, address and telephone number to ensure rapid service.

The instrument should be returned in its original packaging for maximum protection. We regret that transportation damage due to poor packaging is not covered by this warranty.

Maintenance

The most important characteristics of the instruments should be periodically checked according to the instructions provided in the sections "Operational check" and "Alignment procedure". To obtain the normal operating temperature, the mainframe with inserted module should be turned on at least 60 minutes before starting the test. The specified alignment procedure should be strictly observed.

When removing the case detach mains/line cord and any other connected cables from case of the mainframe HM8001. Remove both screws on rear panel and, holding case firmly in place, pull chassis forward out of case. When later replacing the case, care should be taken to ensure that it properly fits under the edges of the front and rear frames.

After removal of the two screws at the rear of the module, both chassis covers can be lifted. When reclosing the module, care should be taken that the guides engage correctly with the front chassis.

Operation of the module

Provided that all hints given in the operating instructions of the HM8001 Mainframe were followed especially for the selection of the correct mains voltage start of operation consists practically of inserting the module into the right or left opening of the mainframe. The following precautions should be observed:

Before exchanging the module, the mainframe must be switched off. A small circle (o) is now revealed on the red power button in the front centre of the mainframe.

If the BNC sockets at the rear panel of the HM8001 unit were in use before, the BNC cables should be disconnected from the basic unit for safety reasons. Slide in the new module until the end position is reached.

Before being locked in place, the cabinet of the instrument is not connected to the protective earth terminal (banana plug above the mainframe multipoint connector). In this case, no test signal must be applied to the input terminals of the module.

Generally, the HM8001 set must be turned on and in full operating condition, before applying any test signal. If a failure of the measuring equipment is detected, no further measurements should be performed. Before switching off the unit or exchanging a module, the instrument must be disconnected from the test circuit.

Control elements of HM8035

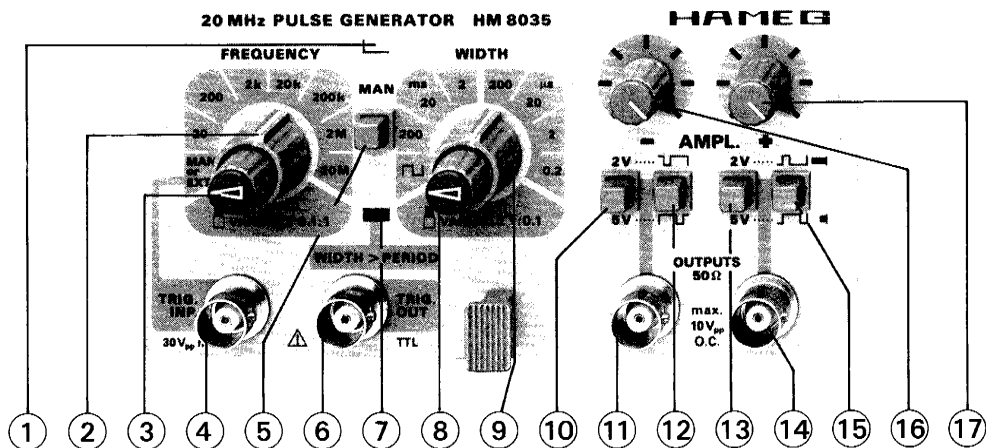

① POWER (LED)

The LED lights up when the module is switched on.

② FREQUENCY (8-position rotary switch)

Selection of pulse repetition frequency in 7 decade steps from 2 Hz up to 20 MHz, external triggering or single pulse operation. If MAN or EXT is selected \square -operation is not possible.

③ VARIABLE (adjusting knob)

Continuous frequency adjustment, overlapping the ranges selected with ②.

④ TRIGGER INPUT (BNC connector)

If ② is in MAN or EXT position, the HM8035 can be triggered by external signals. The signal amplitude required is $>1V_{pk}$ with a minimum pulse duration of 20 ns and a max. frequency of 20 MHz. Maximum admissible input voltage is $\pm 30V$.

⑤ MANUAL (pushbutton)

If ② is in MAN or EXT position a single pulse depending on the setting of ⑧ and ⑨ is generated. ⑨ must not be in \square position.

⑥ TRIGGER OUTPUT (BNC connector)

Short circuit proof, TTL compatible. The output signal is generated by the internal generator or an external trigger signal. Duty cycle and phase condition is similar to the non inverted output signal with a lead time of 10 ns to the main pulse.

⑦ WIDTH > PERIOD (LED)

If the pulse width selected with ⑧ and ⑨ is greater than the pulse period the LED ⑦ lights up intermittently. In this operation mode random pulses are generated.

⑧ VARIABLE (adjusting knob)

Continuous adjustment overlapping the ranges selected with ⑨.

⑨ WIDTH (8-position rotary switch)

Setting of pulse duration in 7 decade steps from 20 ns up to 200 ms and selection of symmetric rectangular pulses with 1:1 duty cycle.

⑩ 2V/5V [⑬] (pushbutton)

Adjustment of output signal attenuation. Output voltage ranges from $< -2V$ to $-5V$ [$< +2V$ to $+5V$] into 50Ω , if 5V is selected (pushbutton pressed), and from $< -0.8V$ to $-2V$ [$< +0.8V$ to $+2V$] into 50Ω , if 2V is selected (pushbutton released).

⑪ OUTPUT NEGATIVE (BNC connector)

Short-circuit-proof signal output. Output impedance is 50Ω . Max. output voltage is $-10V$ o.c. or $-5V$ into 50Ω .

Caution! No external voltage should be applied to this connector.

⑫ COMPLEMENT - [⑮ COMPL. +] (pushbutton)

Selection of normal or inverted negative (positive) output pulses. The output pulses are inverted when the pushbutton is pressed.

⑬ 2V/5V (pushbutton) similar to ⑩.

⑭ OUTPUT POSITIVE (BNC connector)

Similar to ⑪ but negative output voltage.

Caution! No external voltage should be applied to this connector.

⑮ COMPLEMENT + [⑬ COMPL. -] (pushbutton)

Same as ⑫.

⑯ AMPLITUDE - [⑰ AMPLITUDE +] (adjusting knob)

Continuous adjustment of output amplitude from $< -0.8V$ to $-5V$ [$+0.8V$ to $+5V$] into 50Ω and appropriate setting of ⑩/⑬. The output amplitude is twice as high into open circuit.

⑰ AMPLITUDE + [⑯ AMPL. -] (adjusting knob)

Same as ⑯.

Operation

Frequency adjustment

In the normal mode (internal triggering), a coarse frequency adjustment in 7 ranges (from 20 Hz to 20 MHz) is performed by use of the FREQUENCY range switch ② subdivided into decades. The VARIABLE control ③ serves to select the desired frequency. The adjustment ranges are overlapping, i.e. the upper and lower limits of the selected frequency may be exceeded by about 10%.

If the VARIABLE control ③ is set to full right position, the maximum frequency of the selected range is generated. If the VARIABLE control is set to full left position, the HM8035 unit can deliver a frequency, which is lower by a factor of 10 than the maximum frequency of the selected range.

Pulse duration adjustment

The coarse adjustment is performed in 7 ranges (from 200 ns to 200 ms) by use of the WIDTH range switch ⑨ subdivided into decades. The desired pulse duration can be selected using VARIABLE control ⑧. The adjustment ranges are overlapping, i.e. the upper and lower limits of the selected pulse duration range may be exceeded by about 10%. If the VARIABLE control is set to full left position, the maximum pulse width of the output signal is adjusted according to the selected range. If the VARIABLE control is set to full right position, the pulse width is smaller by a factor of about 10 and corresponds to the minimum pulse width of the selected range.

If a pulse duration exceeding the pulse period is selected, the uniform operation of the generator is no longer ensured. This unstable generator condition is indicated by flashing of the WIDTH > PERIOD LED ⑦. This condition may be used for generation of random pulses, i.e. of pulse trains having a random pulse repetition frequency. This is a simple method of providing a random generator.

Symmetric signals

If the WIDTH switch ⑨ is set to \square position, time-symmetric rectangular signals having the frequency adjusted with ② and ③ are generated. The pulse duty factor amounts to $50\% \pm 5\% \pm 10\text{ns}$ in the whole frequency range.

Single pulse activation

If the FREQUENCY switch ② is set to MAN or EXT position, a single pulse will be generated, when the MANUAL pushbutton ⑤ is pressed. The desired pulse duration is adjusted with the WIDTH ⑨ and VARIABLE ⑧ control elements. However, the WIDTH switch ⑧ must not be set to \square position. The shortest pulse duration, which can be selected, is $\leq 20\text{ns}$ and the longest duration is $\geq 200\text{ms}$.

Single pulse activation is also possible by applying a single pulse to the external trigger input ④.

Output signal delivery

The generator can simultaneously deliver positive (+) and negative (-) signals. The voltage levels and polarities of these signals, which are available at the BNC sockets ⑪ and ⑫, can be separately adjusted. Their amplitude can be continuously adjusted with the -⑬ and +⑭ controls. When the 2V/5V buttons ⑩ and ⑬ are pressed, the adjustment range extends from $< 2\text{V}$ up to 5V with a 50 ohms load. In no-load condition, the available signal amplitude is twice as high. The smallest signal voltage to be delivered amounts to $< 800\text{mV}$, when the attenuator is activated. This corresponds to a divider ratio of 2.5:1 or to an attenuation by -8dB .

Both outputs are short-circuit-proof. However, they are not protected against any externally induced voltage. For this reason, no voltage must be applied to the outputs!

If a DC voltage is superimposed to a load resistor, an isolating capacitor having sufficient dielectric strength should be inserted between generator output and load. However, a sufficiently large $C_T \times Z_L$ time constant should be selected to avoid signal deformation due to slopes. A 50 ohms through-termination (such as HZ22) is directly connected to the output to ensure DC feedback of the HM8035 generator current (see fig. 1).

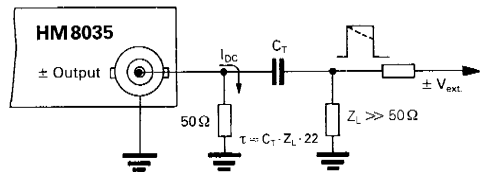

Figure 1 Adaptation to external DC voltages

Due to the short typical switching times of 2.5 ns, the signal always contains high-frequency components, even at low repetition rates ($1/2.5\text{ns} = 400\text{MHz}$). Therefore only high-quality coaxial cables (such as HZ34) should be used for signal transmission.

In any case, care should be taken of correct generator adaptation, when precise rectangular signals are to be delivered. All cables must be terminated with a 50 ohms load to avoid pulse amplitude and waveform distortions.

Complementary signals

The pushbuttons ⑮ and ⑯ permit selection of normal or inverted (complementary) output pulses. This operating condition is particularly suitable to generate very high or very low pulse duty factors. The resulting values are only limited by the minimum pulse duration. For example: if a pulse duration of 200 ns and a pulse repetition frequency of 1 kHz are selected, the pulse duty factor will be as follows, when pushbutton ⑮ or ⑯ is pressed:

$$100 - \frac{t_{\text{WIDTH}}}{T_{\text{PERIOD}}} \cdot 100 = 100 - \frac{200 \cdot 10^{-9}\text{s}}{1 \cdot 10^{-3}\text{s}} \cdot 100 = 99,98\%$$

This example shows that a pulse duty factor of $\leq 99.999996\%$ can be obtained with minimum frequency (2Hz) and pulse duration (200ns). For circuit design reasons, normal and inverted pulses are offset against each other by a fixed time period of less than 10ns (see fig. 3).

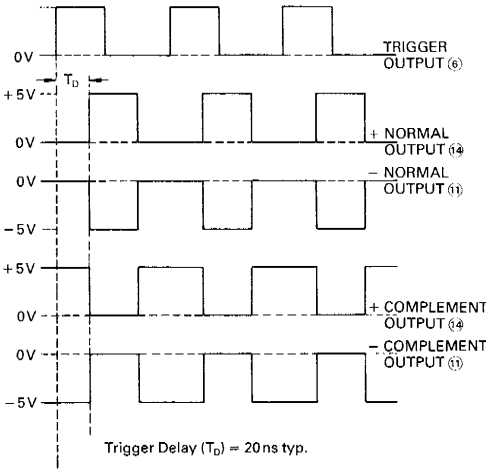

Fig. 2 Output pulses during normal trigger operation

Trigger output

In all operating modes (internal, external and manual triggering), the trigger output (4) delivers a leading rectangular signal in synchronism with the output signal. The trigger signal appears about 20ns before the positive or negative main signal (outputs (f) and (g)). The time delay is fixed, i.e. constant in the whole generator frequency range. The pulse duty factor corresponds always to the values adjusted with the WIDTH (9) and VARIABLE (8) controls.

The trigger output is short-circuit-proof. The output amplitude amounts to 1.9V with a 50 ohms termination and to about 4V with open output. The signal is TTL-compatible (fan-out = 5). To avoid possible crosstalk or pulse distortions due to short rise times, only coaxial cables like HZ34 should be used for connection to other equipment.

Trigger input

If the FREQUENCY switch (2) is set to MAN or EXT position, the internal pulse rate generator is switched off. In this case a signal applied to trigger input (4) determines the pulse repetition frequency of the output signals. As in normal operation, the pulse duration is adjusted with (9) and (8). However, the generator is no longer in symmetrical operating condition. The output signals are triggered with the rising, positive pulse edge. The trigger signal can consist of an AC voltage of $> 1V_p$ or of a rectangular voltage with an amplitude of $> +1V$. The input is TTL-compatible with "1" fan-in. The maximum input voltage can be $\pm 30V$. The minimum pulse duration should not be less than 20ns. The trigger delay from trigger input to trigger output is about 20ns (see fig. 3).

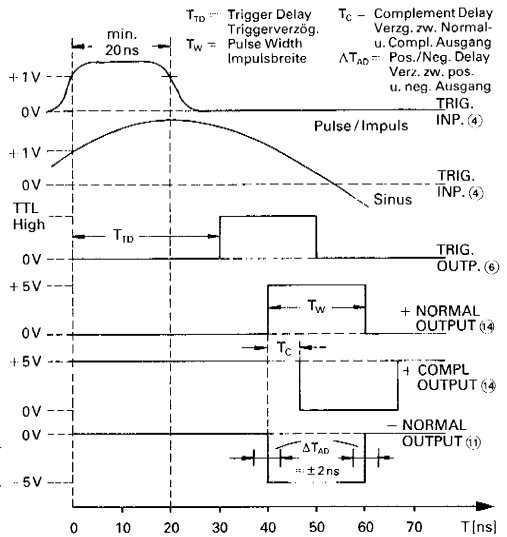

Fig 3 Output signals during external triggering

Manual triggering

Each time the MANUAL pushbutton (5) is pressed, a pulse is activated according to the presetting, the internal pulse rate generator being switched off.

Operational check

General

This test will allow you to check the functions of the HM8035 unit at certain time intervals without using any special test equipment. To obtain the normal operating temperature, the mainframe with inserted module should be turned on at least 30 minutes before starting the test.

Measuring equipment required

- Oscilloscope, bandwidth 60 MHz: HM 605
- HM8021-2 Frequency Counter
- 50 Ω through termination HZ22
- Coaxial Cable HZ34

Frequency variation of all ranges

- a) HM8035 setting:

② FREQUENCY	20 Hz
③ VARIABLE	x0.1 (ccw)
⑧ VARIABLE	x1 (ccw)
⑨ WIDTH	\square
⑰ AMPLITUDE (+)	max.

 no buttons pressed
- b) Connect output (+) (f) of HM8035 to input of HM8021-2. Use coaxial cable and 50 Ω termination.
- c) Check all frequency ranges following the table below.

Frequency variation of all ranges

Range	Frequ. Variable x0.1	Frequ. Variable x1
20Hz	2Hz or less	20Hz or more
200Hz	20Hz or less	200 Hz or more
2 kHz	200Hz or less	2 kHz or more
20kHz	2 kHz or less	20 kHz or more
200kHz	20kHz or less	200kHz or more
2 MHz	200kHz or less	2 MHz or more
20MHz	2MHz or less	20MHz or more

Pulse duration variation of all ranges

- a) HM8035 setting same as for **Frequency variation**
- b) Connect OUTPUT (+) (14) of the HM8035 to Y input of the oscilloscope via coaxial cable. Use 50 Ω termination.
- c) Adjust pulse height to full screen deflection.
- d) Successively select all ranges with the WIDTH (9) and FREQUENCY (2) switches. Set maximum values of the corresponding ranges with VARIABLE CONTROL (8). Read the pulse duration at half screen height and compare the obtained values with those specified in the table below

Pulse duration

Frequ.	Width	Width var. x0.1	Width var. x1
20MHz	0.2 μs	20ns or less	200ns or more
2MHz	2 μs	0.2 μs or less	2 μs or more
200kHz	20 μs	2 μs or less	20 μs or more
20kHz	200 μs	20 μs or less	200 μs or more
2 kHz	2 ms	0.2 ms or less	2 ms or more
200Hz	20 ms	2 ms or less	20 ms or more
20Hz	200 ms	20 ms or less	200 ms or more

Single pulse release

- a) HM8035 setting:
- (2) FREQUENCY MAN or EXT
 - (3) VARIABLE x0.1 (ccw)
 - (8) VARIABLE x1 (ccw)
 - (9) WIDTH 20ms
 - (17) AMPLITUDE (+) max
- no buttons pressed.
- b) Connect OUTPUT (+) (14) of HM8035 to Y input of oscilloscope via coaxial cable. Use 50 Ω termination.
- c) Set oscilloscope to 1V/DIV and 10ms/DIV.
- d) Each release of **MAN**-button generates a 40 ms positive pulse at the screen

Trigger output

- a) HM8035 setting
- (2) FREQUENCY 2MHz
 - (3) VARIABLE x0.1 (ccw)
 - (8) VARIABLE x1 (ccw)
 - (9) WIDTH 2 μs
 - (17) AMPLITUDE (+) max
- b) Connect OUTPUT (+) (14) of HM8035 to Y input of oscilloscope via coaxial cable. Use 50 Ω termination.
- c) Connect trigger output (6) and Y input II of the oscilloscope with a coaxial cable.
- d) Select channel II for triggering the oscilloscope. The signal at the trigger output (6) of the HM8035 unit has the same pulse duty factor as the output signal at OUTPUT (+) (14), which it leads by about 20ns. The signal amplitude at the trigger output is >4V

Operation of WIDTH > PERIOD indicator

- a) Setting of HM8035
- (2) FREQUENCY 20kHz
 - (3) VARIABLE x0.1 (ccw)
 - (8) VARIABLE x0.1 (ccw)
 - (9) WIDTH 2ms
- Other settings optional.
- b) When turning the variable control (8) ccw, after ¼ turns the LED WIDTH > PERIOD starts blinking; that means the pulse duration is greater than the pulse period

Output amplitude

- a) Setting of HM8035
- (2) FREQUENCY 2 kHz
 - (3) VARIABLE x0.1 (ccw)
 - (9) WIDTH □
- b) Connect output (+) (14) of HM8035 to Y-Input of oscilloscope via coaxial cable. Use 50 Ω termination. Check output amplitude following the table below

Positive output voltages OUTPUT (+) (14)

2V/5V(+)	Amplitude (+) x1	Amplitude (+) x10
Pushed	+2V or less	+5V or more
Released	+0.8V or less	+2V or more

- c) Connect output (-) (14) of HM8035 to Y-Input of oscilloscope via coaxial cable. Use 50 Ω termination. Check output amplitude following the table below

Negative output voltages Output (-) (11)

2V/5V(+)	Amplitude (+) x1	Amplitude (+) x10
Pushed	+2V or less	+5V or more
Released	+0.8V or less	+2V or more

Into open circuit the output voltages are twice as high

Test of risetime and falltime

- a) Setting of HM8035:
- | | |
|-------------|------------|
| ② FREQUENCY | 20 MHz |
| ③ VARIABLE | x0.1 (ccw) |
| ⑥ WIDTH | □ |
- b) Connect output (+) ⑭ of HM8035 to Y-Input of oscilloscope via coaxial cable. Use 50 Ω termination.
- c) Set oscilloscope to 0.5V/DIV. and 0.05 μs/DIV.; X-magnifier x10.
- d) Adjust screen deflection to 6DIV. with Amplitude control (+) ⑰.
- e) Measure risetime between 10% and 90% indicator on screen. The obtained value should not exceed 6.5 ns. The effective risetime is subject to calculation with the following formula.
- $$T_{\text{sig}} = \sqrt{T_{\text{mes}}^2 - T_{\text{osc}}^2}$$
- $$T_{\text{sig}} = \sqrt{6.5 \text{ ns}^2 - 5.8 \text{ ns}^2} = 3 \text{ ns}$$
- T_{sig} = signal risetime
 T_{mes} = measured risetime
 T_{osc} = Risetime of oscilloscope (HM605 \triangleq 5.8 ns)
- f) Push SLOPE pushbutton on oscilloscope. Repeat similar measurement for falltime.
- g) Repeat measurements b) to f) for output (-) ⑪.

Overshoot

- a) Setting of HM8035:
- | | |
|------------------|------------|
| ② FREQUENCY | 2 MHz |
| ③ FREQ. VARIABLE | x1 (cw) |
| ⑨ WIDTH | □ |
| ⑰ AMPLITUDE (+) | min. (ccw) |
| ⑰ AMPLITUDE (-) | min. (ccw) |
| ⑪ 2V/5V (+) | pushed |
| ⑬ 2V/5V (-) | pushed |
| ⑮ COMPLEMENT (+) | released |
| ⑫ COMPLEMENT (-) | released |
- b) Connect output (+) ⑭ of HM8035 to Y-Input of oscilloscope via coaxial cable. Use 50 Ω termination.
- c) Set oscilloscope to 0.5V/cm and 0.05 μs/cm. Adjust screen deflection to 6 DIV. with Amplitude control (+) ⑰.
- d) Overshoot should not exceed 0.3 DIV. (Fig. 4).
- e) Connect output (-) ⑪ of HM8035 to Y-input of oscilloscope.
- f) Measurement similar b) to d).

Alignment procedure

The following instructions will permit you to correct any deviation of the module from the nominal data. The specified alignment sequence should be strictly observed.

Before opening the set, you should carefully read the **Safety** and **Warranty** information on page M2 of these operating instructions.

A – Symmetry of output signal

- a) **Setting:**
- | | | | | |
|--------|------|---|------|------|
| ② | ③ | ⑨ | ⑰ | ⑰ |
| 20 MHz | x0.1 | □ | max. | max. |
- all pushbuttons released
- b) Connect output (+) ⑭ of HM8035 to Y-Input of oscilloscope via coaxial cable. Use 50 Ω termination. Adjust timebase in such a way that the positive pulse-duration on the screen is 10 DIV. long.
- c) Set trigger of oscilloscope to negative slope.
- d) Adjust VR 101 ① for the same screen image of positive and negative pulse duration.

B – Output amplitude

- a) **Setting:**
- | | | |
|--------|------|------|
| ⑨ | ⑰ | ⑰ |
| 0,2 μs | max. | max. |
- all pushbuttons pressed
- b) Connect DMM HM8011-3 (20VDC range) to output ⑭ of HM8035. Use HZ32 and 50 Ω termination.
- c) Press pushbutton MAN ⑤. Adjust VR 102 ② to obtain + 5V display on HM8011-3.
- d) Connect the HM8011-3 to output ⑪ of HM8035. Use HZ32 and 50 Ω termination.
- e) Press pushbutton MAN ⑤. Adjust VR 104 ④ to obtain - 5V display on HM8011-3.

C – Square wave calibration

- a) **Setting:**
- | | | | | |
|--------|------|---|------|------|
| ② | ③ | ④ | ⑰ | ⑰ |
| 20 MHz | x0,1 | □ | max. | max. |
- Pushbutton ⑩ and ⑬ pushed
Pushbutton ⑫ and ⑮ released
- b) Connect output ⑭ of HM8035 to Y-input of an oscilloscope with $F_T \gg 100 \text{ MHz}$. Use coaxial cable and 50 Ω termination.
- c) Adjust VR 103 ③ and VC 101 ⑥ to obtain minimum aberration at the rising edge.
- d) same as b) for output ⑪ of HM8035.
- e) Adjust VR 105 ⑤ and VC 102 ⑦ to obtain minimum aberration at the falling edge.

Definition of pulse characteristic

Aberration. (Waveform error). Undesired deviation of pulseform related to an ideal square wave signal without overshoot, ramp-off and ringing.

Amplitude. Maximum peak value of a pulse related to its baseline without overshoot or ringing. Measuring points are the horizontal 50% points of the pulse duration (pulse high level).

Baseline. DC reference voltage of a pulse.

Complementary pulses. Pulse on-time and pulse off-time are inverted relative to the normal pulse.

Duty cycle. Relation between pulse duration and pulse period. Duty cycle in % is pulse duration/pulse periode x 100.

Falltime. The time it takes the signal to fall from 90% to 10% of signal amplitude.

Jitter. Short-time instabilities of pulse frequency at the rising and falling pulse slopes. The pulse periode-jitter (jitter of rising slope) and the pulse duration-jitter (jitter of falling slope) are specified in % of 100% duty cycle.

Linearity. Peak deviation of the pulse slope from the straight line between 10% and 90% points of the pulse amplitude. Specified in % of 100% signal amplitude.

Overshoot. Short peaks at pulse top after rising or falling slope. Specification is in % of 100% signal amplitude.

Preshot. Transient distortion leading positive pulse slope, with same or inverted polarity of pulse.

Pulse duration. (Pulse on-time). Time interval between rising and falling pulse slope. Measuring points are the vertical 50% points of the signal amplitude.

Pulse off-time. Result of pulse period minus pulse duration.

Ramp off. Distortion of the pulse top, excluding overshoot and ringing. It is characterized by the deviation from the straight pulse top and specified in percent of 100% signal amplitude.

Ringing. Periodically damped oscillation superimposed on the pulse top. Specified in % of 100% signal amplitude

Risetime. The time it takes the signal to rise from 10% to 90% of signal amplitude.

Rounding. Rounding of pulses at upper and lower edges of the pulse slope.

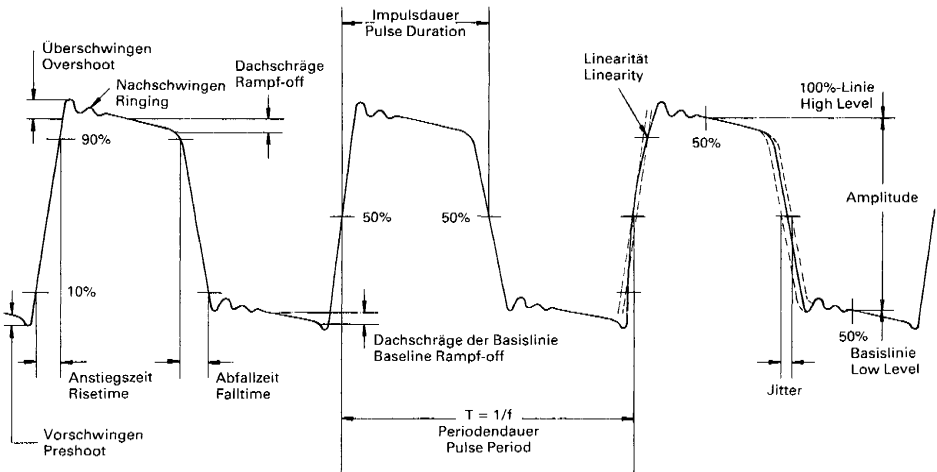
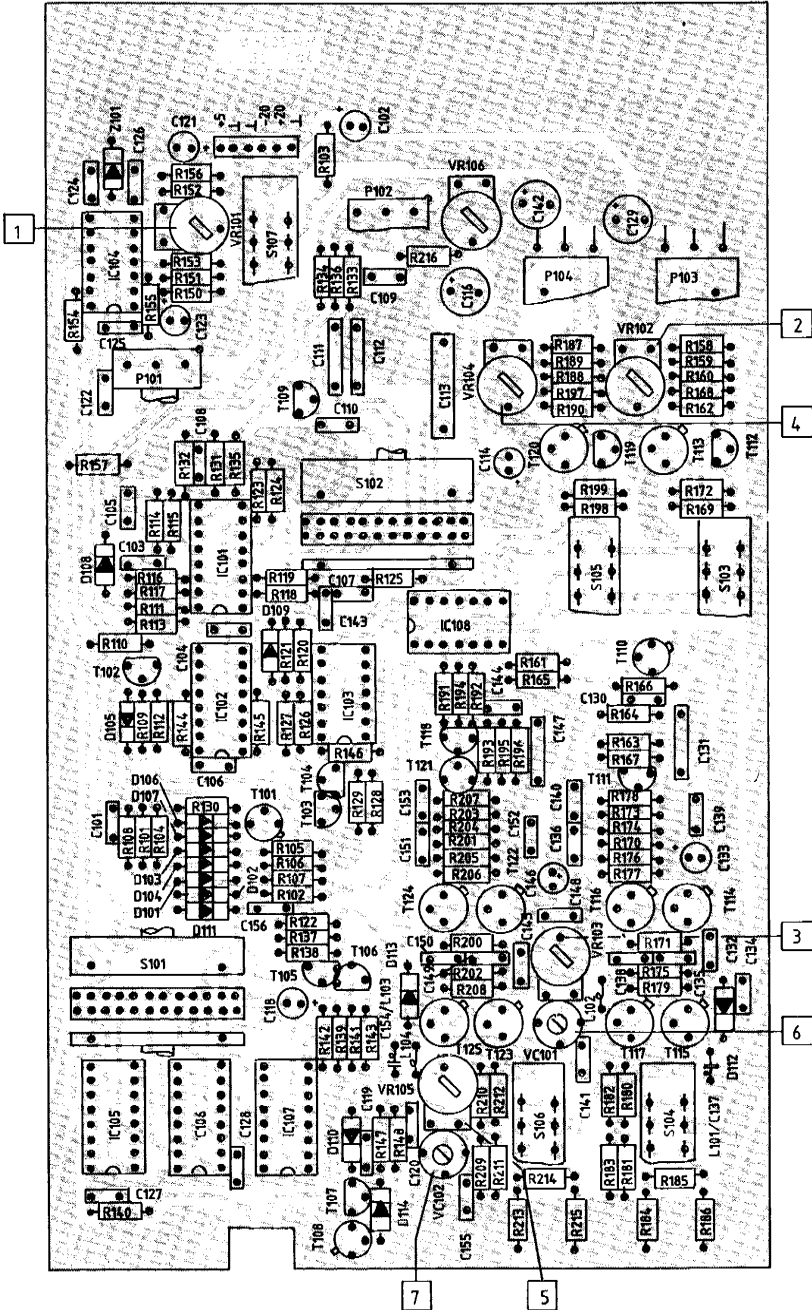

Fig. 4 Definition of pulse characteristic

Bestückungsplan, Hauptplatte
Implantation des composants

Component Locations
Localizacion de componentes



Impulsgenerator, Triggerlogik Générateur d'impulsion, logique de déclenchement

Pulse Generator, Trigger Logic Impulsogenerador, Triggerlógica

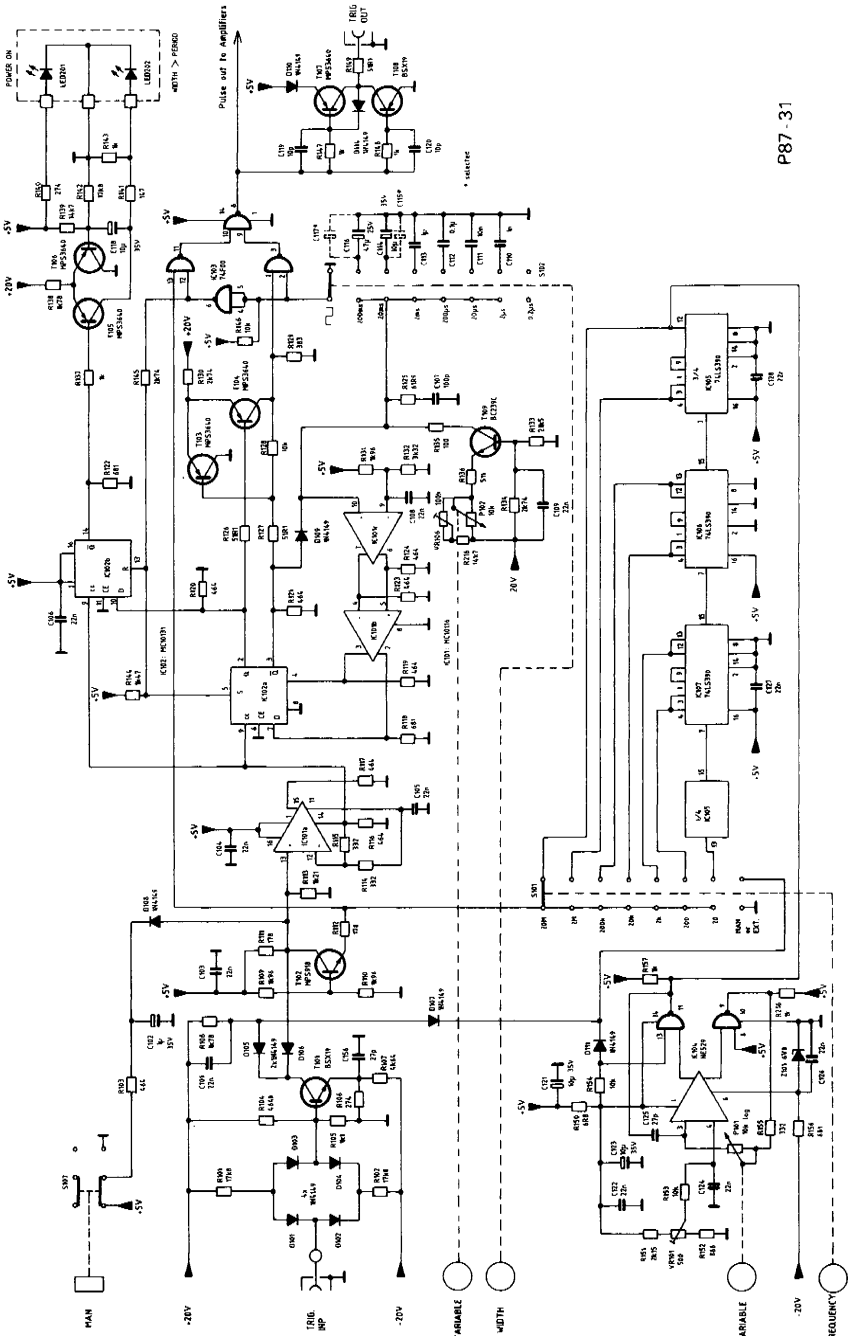

Endverstärker
Amplificateur de sortie

Output Amplifier
Amplificador

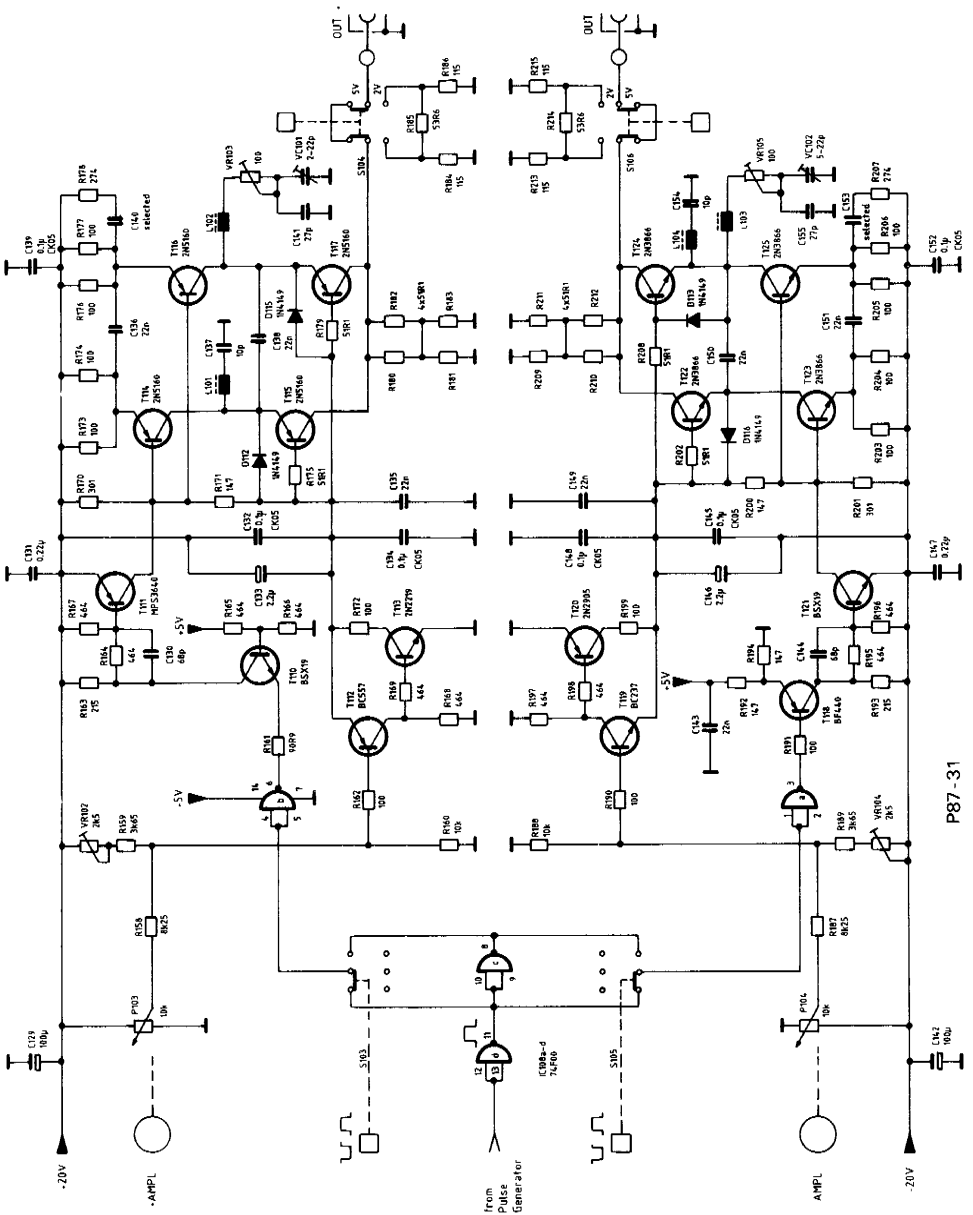

P87-31

Liste elektronischer Teile

Electronic Parts List

Ref. No.	Description	Ref. No.	Description	Ref. No.	Description
R 101	102 17,8kΩ 1% TK 50	R 172	174 100 Ω 1% TK 50	C 134-136	0,1 μF 50V CK05
R 103-104	464 Ω	R 175	51,1 Ω	C 137	10pF 63V
R 105	1,1kΩ	R 176	177 100 Ω	C 138	22nF 63V 20%
R 106	2,74 Ω	R 178	274 Ω	C 139	0,1 μF 50V CK05
R 107	4,64kΩ	R 179-183	51,1 Ω	C 140	10pF 63V 10%
R 108	1,78kΩ	R 184	115 Ω	C 141	27pF 63V
R 109-110	1,96kΩ	R 185	53,6 Ω	C 142	100 μF 35V
R 111-112	178 Ω	R 186	115 Ω	C 143	22nF 63V 20%
R 113	1,21kΩ	R 187	8,25kΩ	C 144	68pF 63V
R 114	115 332 Ω	R 188	10kΩ	C 145	0,1 μF 50V CK05
R 116	117 464 Ω	R 189	3,65kΩ	C 146	2,2 μF 63V
R 118	681 Ω	R 190	191 100 Ω	C 147	0,22 μF 100V 20%
R 119-121	464 Ω	R 192	147 Ω	C 148	0,1 μF 50V CK05
R 122	681 Ω	R 193	215 Ω	C 149	0,1 μF 50V CK05
R 123	124 464 Ω	R 194	147 Ω	C 150-151	22nF 63V 20%
R 125	61,9 Ω	R 195-198	464 Ω	C 152	0,1 μF 50V CK05
R 126-127	51,1 Ω	R 199	100 Ω	C 153-154	10pF 63V 10%
R 128	10kΩ	R 200	147 Ω	C 155-156	27pF 63V
R 129	383 Ω	R 201	301 Ω	D 101-116	1N4149
R 130	2,74kΩ	R 202	51,1 Ω	IC 101	MC10116
R 131	1,96kΩ	R 203-206	100 Ω	IC 102	MC10131
R 132	3,32kΩ	R 207	274 Ω	IC 103	SN74 F00
R 133	21,5 Ω	R 208-212	51,1 Ω	IC 104	NE529
R 134	3,65kΩ	R 213	115 Ω	IC 105	107 SN74LS390
R 135	100 Ω	R 214	53,6 Ω	IC 108	SN74 F00
R 136	681 Ω	R 215	115 Ω	LED 201 202	TL SG5101
R 137	1kΩ	R 216	1kΩ	T 101	B SX 19
R 138	1,78kΩ	C 101	22nF 63V 20%	T 102	MPS918
R 139	14,7kΩ	C 102	1 μF 35V	T 103	107 MPS3640
R 140	274 Ω	C 103-106	22nF 63V 20%	T 108	MPS918
R 141	147 Ω	C 107	100pF 63V NPO 10%	T 109	BC239C
R 142	17,8kΩ	C 108-109	22nF 63V 20%	T 110	B SX 19
R 143	1kΩ	C 110	1nF 63V NPO 10%	T 111	MPS3640 sel.
R 144	1,47kΩ	C 111	10nF 630V 20%	T 112	BC557
R 145	2,74kΩ	C 112	0,1 μF 400V 20%	T 113	2N2219
R 146	10kΩ	C 113	1 μF 35V	T 114-117	2N5160
R 147	148 1kΩ	C 114	10 μF 35V	T 118	BF440
R 149	51,1 Ω	C 115	adjustment	T 119	BC237
R 150	6,8 Ω	C 116	100 μF 25V	T 120	2N2905
R 151	3,32kΩ	C 117	adjustment	T 121	B SX 19 sel.
R 152	1,21kΩ	C 118	10 μF 35V	T 122-125	2N3866
R 153-154	10kΩ	C 119-120	10pF 63V	VR 101	500 Ω 20% lin
R 155	332 Ω	C 121	10 μF 35V	VR 102	2,5kΩ 20% lin
R 156	681 Ω	C 122	22nF 63V 20%	VR 103	100 Ω 20% lin
R 157	1kΩ	C 123	10 μF 35V	VR 104	2,5kΩ 20% lin
R 158	8,25kΩ	C 124	22nF 63V 20%	VR 105	100 Ω 20% lin
R 159	3,65kΩ	C 125	27pF 63V	VC 101	2-22pF
R 160	10kΩ	C 126	128 22nF 63V 20%	VC 102	5-22pF
R 161	90,9 Ω	C 129	100 μF 35V	P 101-104	10kΩ neg. log
R 162	100 Ω	C 130	68pF 63V	L 101-104	Ferrit Perle
R 163-169	215 Ω	C 131	0,22 μF 100V 20%		
R 170	301 Ω	C 132	0,1 μF 50V CK05		
R 171	147 Ω	C 133	2,2 μF 100V 20%		

Steckerleiste, Versorgungsspannungen Multipoint connector, supply voltages Carte connecteur, tensions d'alimentation Placa conector de los voltajes de alimentación

R401, R402:
 Programmwiderstände
 Programming Resistors
 Résistances de programmation
 Resistencia según programa
 = 1.3kΩ

