



99 Washington Street  
Melrose, MA 02176  
Phone 781-665-1400  
Toll Free 1-800-517-8431

 Visit us at [www.TestEquipmentDepot.com](http://www.TestEquipmentDepot.com)



# Link Aggregating In-Line Taps

**ATAP-100 SERIES**  
**ATAP-GIG SERIES**  
**ATAP-2000 SERIES**

**USER GUIDE**

PN 2527819 [rev. 4, 9/07]  
October 2005

© 2007 Fluke Corporation. All rights reserved. Printed in USA.  
All product names are trademarks of their respective companies.

## COMPLIANCE TESTING

### CAUTION

*Changes or modifications to this unit not expressly approved by the party responsible for compliance could void the user's authority to operate the equipment.*

### NOTE

*This equipment has been tested and found to comply with the limits for a **Class A** digital device, pursuant to **Part 15** of the FCC Rules. These limits are designed to provide reasonable protection against harmful interference when the equipment is operated in a commercial environment. This equipment generates, uses and can radiate radio frequency energy and, if not installed and used in accordance with the instruction manual, may cause harmful interference to radio communications. Operation of this equipment in a residential area is likely to cause harmful interference in which case the user will be required to correct the interference at one's own expense.*

## CE CERTIFICATIONS

This equipment has been tested and found to meet the radiated and conducted emission limits for a **Class B** product of **EN 55022** to the **EMC Directive 89/336/EEC** requirements.

This equipment has been tested and found to meet the immunity levels for **Class 1**, tested to **level 2** for **EN 6100-4-2**, tested to **level 3** for **EN 61000-4-3**, tested to **level 2** for **EN 61000-4-4**, and tested to **level 3** for **EN 61000-4-5** to the **EN 50082-1** requirements and meets the **Class A** requirements for **EN 61000-3-2** and **EN 61000-3-3**.

This equipment has completed the Product Safety Review and found to meet the **Low Voltage Directive 72/23/EEC (1993)** requirements.

## Limited Warranty & Limitation of Liability

Each Fluke Networks product is warranted to be free from defects in material and workmanship under normal use and service. The warranty period for the mainframe is two years and begins on the date of purchase. Parts, accessories, product repairs and services are warranted for 90 days, unless otherwise stated. Ni-Cad, Ni-MH and Li-Ion batteries, cables or other peripherals are all considered parts or accessories. The warranty extends only to the original buyer or end user customer of a Fluke Networks authorized reseller, and does not apply to any product which, in Fluke Networks' opinion, has been misused, abused, altered, neglected, contaminated, or damaged by accident or abnormal conditions of operation or handling. Fluke Networks warrants that software will operate substantially in accordance with its functional specifications for 90 days and that it has been properly recorded on non-defective media. Fluke Networks does not warrant that software will be error free or operate without interruption.

Fluke Networks authorized resellers shall extend this warranty on new and unused products to end-user customers only but have no authority to extend a greater or different warranty on behalf of Fluke Networks. Warranty support is available only if product is purchased through a Fluke Networks authorized sales outlet or Buyer has paid the applicable international price. Fluke Networks reserves the right to invoice Buyer for importation costs of repair/replacement parts when product purchased in one country is submitted for repair in another country.

Fluke Networks warranty obligation is limited, at Fluke Networks option, to refund of the purchase price, free of charge repair, or replacement of a defective product which is returned to a Fluke Networks authorized service center within the warranty period.

To obtain warranty service, contact your Technical Assistance Center. Support information can be found in the System Recovery section at the end of this manual. Fluke Networks assumes no risk for damage in transit. Following warranty repair, the product will be returned to Buyer, transportation prepaid (FOB destination). If Fluke Networks determines that failure was caused by neglect, misuse, contamination, alteration, accident or abnormal condition of operation or handling, or normal wear and tear of mechanical components, Fluke Networks will provide an estimate of repair costs and obtain authorization before commencing the work. Following repair, the product will be returned to the Buyer transportation prepaid and the Buyer will be billed for the repair and return transportation charges (FOB Shipping point).

THIS WARRANTY IS BUYER'S SOLE AND EXCLUSIVE REMEDY AND IS IN LIEU OF ALL OTHER WARRANTIES, EXPRESS OR IMPLIED, INCLUDING BUT NOT LIMITED TO ANY IMPLIED WARRANTY OR MERCHANTABILITY OR FITNESS FOR A PARTICULAR PURPOSE. FLUKE NETWORKS SHALL NOT BE LIABLE FOR ANY SPECIAL, INDIRECT, INCIDENTAL OR CONSEQUENTIAL DAMAGES OR LOSSES, INCLUDING LOSS OF DATA, ARISING FROM ANY CAUSE OR THEORY.

Since some countries or states do not allow limitation of the term of an implied warranty, or exclusion or limitation of incidental or consequential damages, the limitations and exclusions of this warranty may not apply to every buyer. If any provision of this Warranty is held invalid or unenforceable by a court or other decision-maker of competent jurisdiction, such holding will not affect the validity or enforceability of any other provision.

**FLUKE NETWORKS P.O. BOX 777 EVERETT, WA 98206-0777 USA**

# Table of Contents

<b>COMPLIANCE TESTING</b>	<b>ii</b>
<b>CERTIFICATIONS</b>	<b>ii</b>
<b>LIMITED WARRANTY &amp; LIMITATION OF LIABILITY</b>	<b>iii</b>
<b>PREFACE</b>	<b>2</b>
<b>INTRODUCTION</b>	<b>3</b>
<i>Aggregating Tap summary information</i>	3
<b>OVERVIEW</b>	<b>4</b>
<b>FEATURES AND BENEFITS</b>	<b>5</b>
<b>ATAP-100 SERIES</b> SINGLE NETWORK PORT + DUAL TAP	<b>6</b>
<i>Introduction</i>	6
<i>Using ATAP-100 with a STAP-100-2X16 Copper Span Tap</i>	7
<i>Using ATAP-100 with a TAP-100-2X16 Copper Span Tap</i>	8
<i>Panel description:</i>	
ATAP-100	9
ATAP-101	9
ATAP-102	9
ATAP-103	9
<i>Tap functionality</i>	11
<i>Hardware installation</i>	11–13
<b>Table:</b> <i>General specifications</i>	13
<b>ATAP-GIG SERIES</b> SINGLE NETWORK PORT + DUAL TAP GIGABIT	<b>14</b>
<i>Introduction</i>	14
<i>Panel description</i>	15
<b>Table:</b> <i>LED display codes</i>	15
<i>Panel display and functionality:</i>	
ATAP-GIG-BT-BT	16
ATAP-GIG-BT-SX	16
ATAP-GIG-SX-BT / ATAP-GIG-LX-BT	17
ATAP-GIG-SX-SX	17
<i>Hardware installation</i>	18
<b>Table:</b> <i>General specifications</i>	19

## Table of Contents continued

<b>ATAP-2000 SERIES DUAL NETWORK PORT + DUAL TAP GIGABIT</b>	<b>20</b>
<i>Introduction</i>	21
<i>Application</i>	21
<i>Panel description</i>	
ATAP-2000-BT-BT	22
ATAP-2000-SX-SX	22
ATAP-2000-LX-SX	22
ATAP-2001-BT-BT	22
<i>Hardware installation</i>	22–23
<b>Table:</b> <i>General specifications</i>	23
<b>CARE AND MAINTENANCE</b>	<b>24</b>
<i>Avoiding rough handling</i>	24
<i>Cleaning carefully</i>	24
<i>Providing adequate ventilation</i>	24
<i>Safety information</i>	24
<i>Service and adjustment</i>	24
<b>CONTACTING FLUKE NETWORKS</b>	<b>25</b>

# Preface

## **AUDIENCE**

This hardware guide is written for the person who must install and connect a Fluke Networks Link Aggregating In-Line Tap. The installer is assumed to be familiar with Windows9x/NT/2000/XP, knows how networks operate, and has operating knowledge of network appliances used in network analyzing configurations.

This hardware guide was written to help you get to know your new Link Aggregating In-Line Tap quickly and easily. We welcome any comments or suggestions you may have regarding this hardware guide.

# Introduction

Like many network managers, you know how critical your networks are to your company's success. Your network's fiber links carry high volume traffic and are absolutely pivotal to your company's performance. With the Fluke Networks Link Aggregating In-Line Taps series, you can now handle network issues remotely and seamlessly without making a visit to the site.

Each Link Aggregating In-Line Tap provides access for meeting whatever monitoring or analysis requirements you may have. It also allows the sharing of network tools between network segments. Your tools can be quickly and effectively deployed to the point of failure, expanding visibility to the farthest reaches of your networks.

## LINK AGGREGATING IN-LINE TAP SUMMARY INFORMATION

MODEL	NETWORK PORTS	TAP PORTS	PASSIVE	RELAY FAILOVER	INJECTION	REDUNDANT POWER	SUPPORTS POE	RACK MOUNT
ATAP-100	10/100BASE-T	2 @ 10/100BASE-T	no	yes	yes	no	no	TAP-RMK-3 / TAP-RMK-14
ATAP-101	100BASE-T	2 @ 100BASE-T	yes	n/a	no	yes	yes	TAP-RMK-3 / TAP-RMK-14
ATAP-102	100BASE-T	2 @ 10/100BASE-T	yes	no	no	yes	yes	TAP-RMK-3 / TAP-RMK-14
ATAP-103	10/100BASE-T	2 @ 100BASE-T	no	yes	yes	no	no	TAP-RMK-3 / TAP-RMK-14
ATAP-GIG-BT-BT	10/100/1000BASE-T	2 @ 10/100/1000BASE-T	no	yes	yes	yes	no	TAP-RMK-2
ATAP-GIG-BT-SX	10/100/1000BASE-T	2 @ 1000BASE-SX LC	no	yes	yes	yes	no	TAP-RMK-2
ATAP-GIG-SX-BT	1000BASE-SX	2 @ 1000BASE-T	yes [MM splitter]	n/a	no	yes	n/a	TAP-RMK-2
ATAP-GIG-SX-SX	1000BASE-SX	2 @ 1000BASE-SX LC	yes [MM splitter]	n/a	no	yes	n/a	TAP-RMK-2
ATAP-GIG-LX-BT	1000BASE-LX	2 @ 1000BASE-T	yes [SM splitter]	n/a	no	yes	n/a	TAP-RMK-2
ATAP-2000-BT-BT	2 @ 10/100/1000BASE-T	2 @ 10/100/1000BASE-T	no	yes	yes	yes	no	TAP-RMK-2
ATAP-2000-SX-SX	2 @ 1000BASE-SX LC	2 @ 1000BASE-SX LC	yes [MM splitter]	n/a	no	yes	n/a	TAP-RMK-2
ATAP-2000-LX-SX	2 @ 1000BASE-LX LC	2 @ 1000BASE-SX LC	yes [SM splitter]	n/a	no	yes	n/a	TAP-RMK-2
ATAP-2001-BT-BT	2 @ 1000BASE-T	2 @ 1000BASE-T	no	yes	no	yes	no	TAP-RMK-2

## Overview

Each Fluke Networks Link Aggregating In-Line Tap provides superior 24x7 monitoring of full-duplex Ethernet links.

Many ethernet taps have traditionally enabled full-duplex monitoring of all network link traffic by transmitting data to a monitoring device (i.e., analyzer, IDS or probe) with two separate half-duplex streams. Unfortunately, this requires the monitoring device to be equipped with two network interface cards (NIC). It also requires that the device be capable of combining and processing both streams of data in order to monitor both sides of the conversation.

Enter Fluke Networks Link Aggregating In-Line Taps. Each tap faultlessly combines the two data streams, enabling any connected monitoring device to receive a full-duplex stream of data with only one NIC.

Further, each Link Aggregating In-Line Tap provides a unique second tap port to help manage network resources. With this extra tap port, two separate devices (such as an analyzer and an intrusion detection device) can receive the same full-duplex transmission. This feature prevents multiple devices from competing for access to your network link.

Fluke Networks Link Aggregating In-Line Taps are ideal for use in networks where bandwidth utilization is consistently under 50% on each side. Each tap can also help avert data overload and dropped packets that can arise from “traffic bursts” — sudden, temporary increases in utilization. A built-in memory buffer manages overflows in data transmission and allows for seamless continuity of full-duplex monitoring.

Fluke Networks Link Aggregating In-Line Taps are completely non-intrusive. Each tap’s redundant power supply and industry-leading, fault-tolerant design have been thoroughly tested. In the event that power is lost to the tap, network traffic will continue to flow without interruption.

## Features and Benefits

- **Simple plug-and-play** solution requires no additional configuration of external monitoring devices.
- **Connect** protocol analyzers, probes, intrusion detection systems and other devices for permanent, in-line monitoring of full-duplex links. Eliminate the inconvenience of disconnecting and reconnecting the network each time a segment requires monitoring.
- **Proven performance.** Industry-leading, non-intrusive and fault-tolerant.
- **ATAP-100** series models. Operate at either 10Mbps or 100Mbps while supporting full-duplex and half-duplex auto-negotiation.
- **ATAP-GIG** series models. Operate at 10Mbps, 100Mbps or 1,000 Mbps while supporting full-duplex and half-duplex auto-negotiation.
- **ATAP-2000** series models. Operate at 10Mbps, 100Mbps or 1,000 Mbps while supporting full-duplex and half-duplex auto-negotiation on a primary and secondary link.
- **Two tap ports.** Allow two devices to monitor the same link simultaneously, which provides for extended security and analysis options while eliminating device competition for network access.
- **Memory buffer.** Manages traffic burst exceeding 100% of a single NIC utilization, which prevents data overload and dropped packets while maintaining full-duplex monitoring continuity.
- **Redundant power.** Ensures uninterrupted monitoring by eliminating power single-point-of-failure. This results in seamless monitoring, even if the primary power source is unavailable.
- **Network transparency.** Will not interfere with data traffic.
- **Easy to install.** Optional 3-unit, 1U (TAP-RMK-3) or 14-unit, 4U (TAP-RMK-14) rack mounts available for ATAP-100 series models; 2-unit, 1U (TAP-RMK-2) rack mount available for ATAP-GIG and ATAP-2000 series models.

### ADVANTAGE OVER TRADITIONAL SPAN MONITORING

SPAN ports often lose excess data due to limited buffering support. Fluke Networks Link Aggregating In-Line Taps contain memory buffers on both sides of the full-duplex link. This enables seamless monitoring without data loss — even when 100% utilization is exceeded on a monitoring device's single NIC.

# ATAP-100 Series Single Network Port + Dual Tap

## INTRODUCTION

By using the ATAP-100 Link Aggregating In-Line Tap, two monitoring devices can receive combined traffic from both sides of a network conversation. Only one Network Interface Card (NIC) is needed by each monitoring device to detect and monitor all combined traffic.

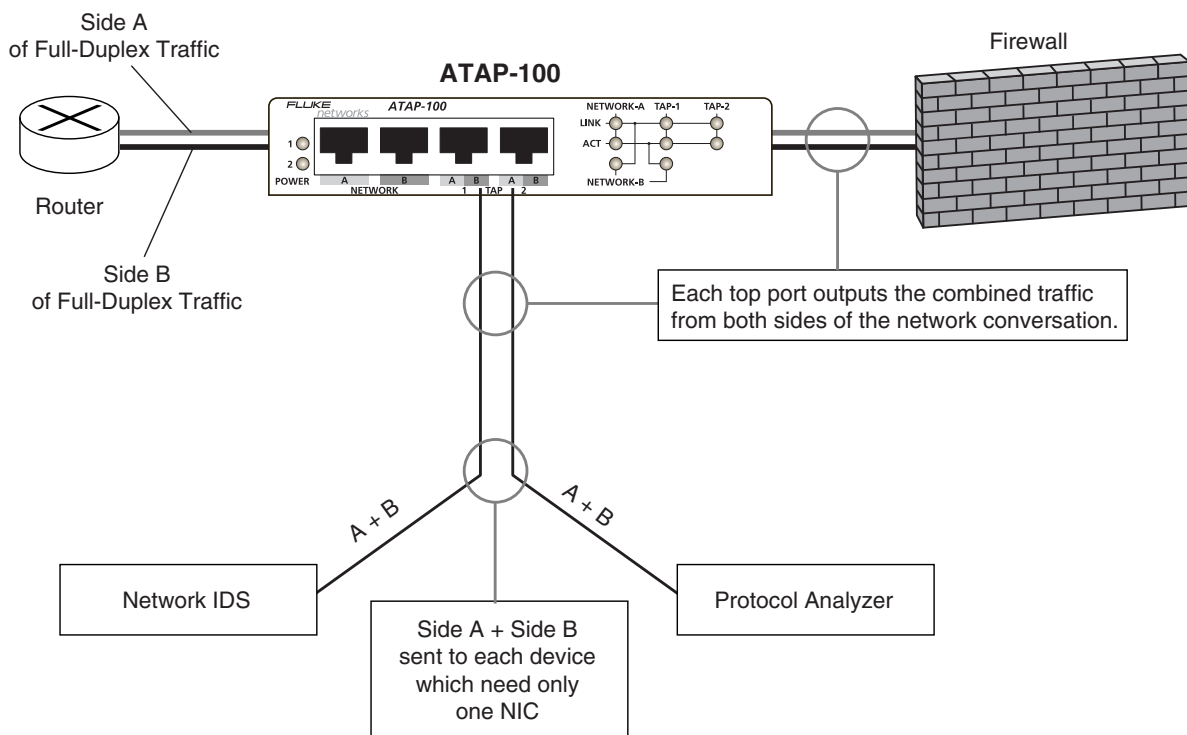

Figure 1. Typical ATAP-100 Link Aggregating In-Line Tap connectivity diagram

**Figure 1** depicts a typical ATAP-100 Link Aggregating In-Line Tap scenario. Two monitoring devices receive all the combined traffic from both sides of the network conversation. Only one NIC is required by each device to see the combined traffic.

# ATAP-100 Series Single Network Port + Dual Tap

## USING ATAP-100 WITH A STAP-100-2X16 COPPER SPAN TAP

Figure 2 shows a typical ATAP-100 Link Aggregating In-Line Tap scenario in conjunction with a Fluke Networks STAP-100-2X16 Copper Span Tap. Move two analyzers in and out of the 16 links for roving analysis. Tap into your link with an ATAP-100 unit, which enables reception of aggregated data from the network link. Connect an IDS device to the ATAP-100's second tap port for 24x7 monitoring. This eliminates contention for access to the same SPAN port. You can use up to sixteen ATAP-100 taps with the STAP-100-2X16.

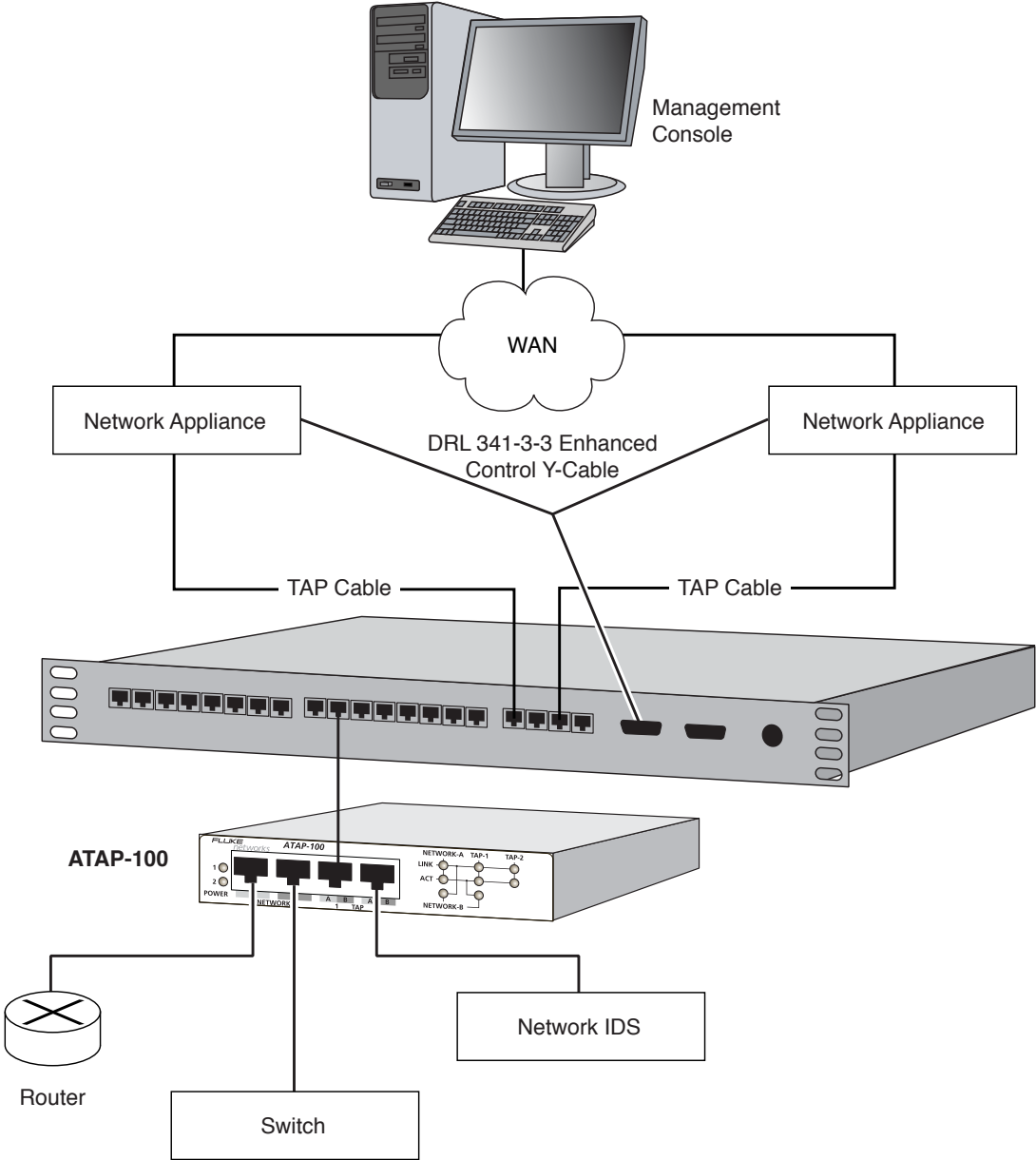

Figure 2. ATAP-100 Link Aggregating In-Line Tap connected to STAP-100-2X16 Copper Span Tap

## ATAP-100 Series Single Network Port + Dual Tap

### USING ATAP-100 WITH A TAP-100-2X16 COPPER SPAN TAP

**Figure 3** shows two ATAP-100 Link Aggregating In-Line Taps connected to a TAP-100-2X16 switch. Move either network analyzer in and out of any of the sixteen tapped links for non-intrusive and roving, full-duplex analysis. Alternately, you may permanently leave in-line the second analyzer and intrusion detection device on any of the TAP-100-2X16 ports for 24x7 full-duplex analysis and monitoring.

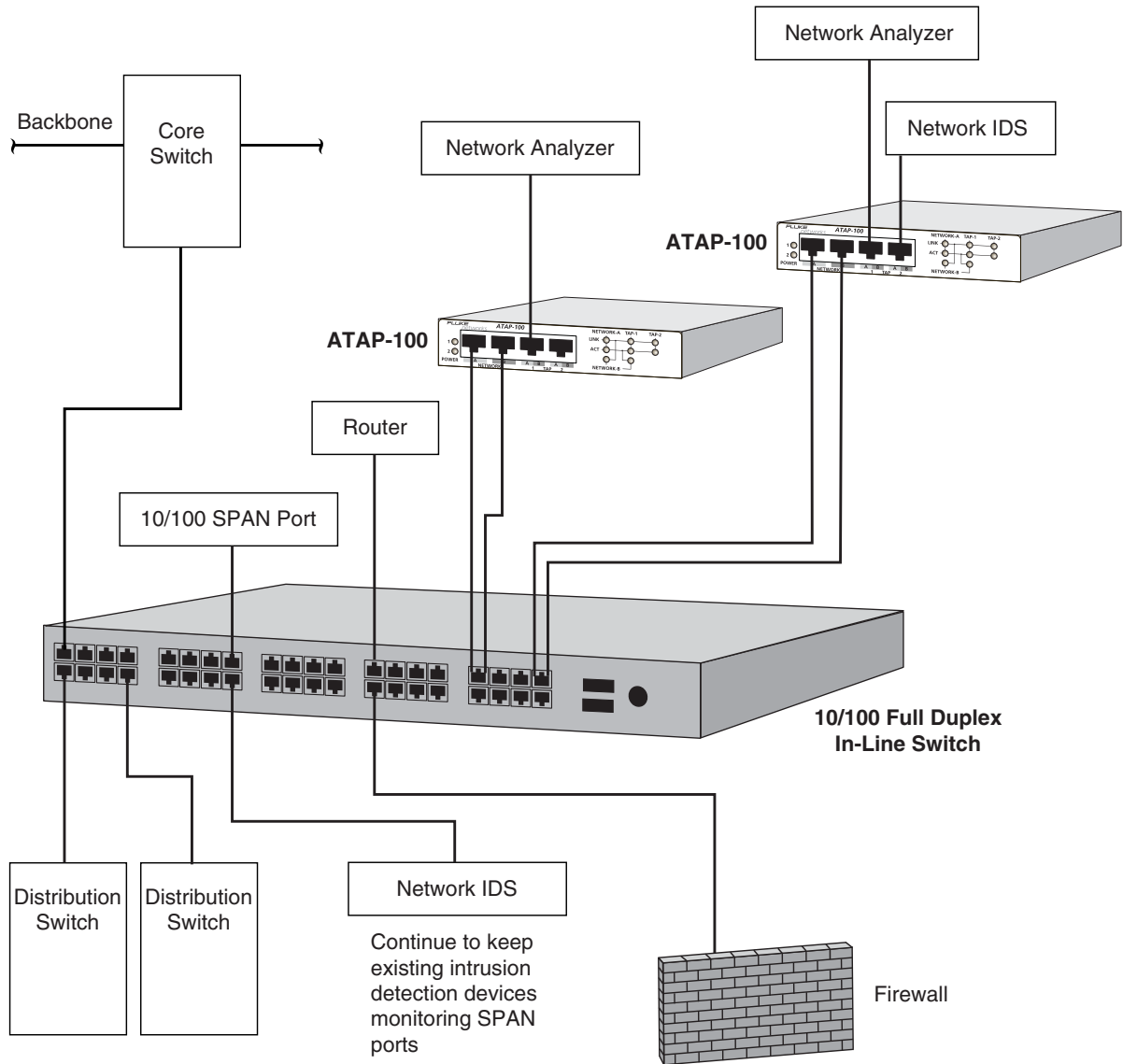

Figure 3. Two ATAP-100 Link Aggregating In-Line Taps connected to a STAP-100-2X16 Copper Span Tap

# ATAP-100 Series Single Network Port + Dual Tap

## PANEL DESCRIPTION

**Figure 4** displays the ATAP-100 Link Aggregating In-Line Tap front panel. This is the location for all cable connections and status LEDs.

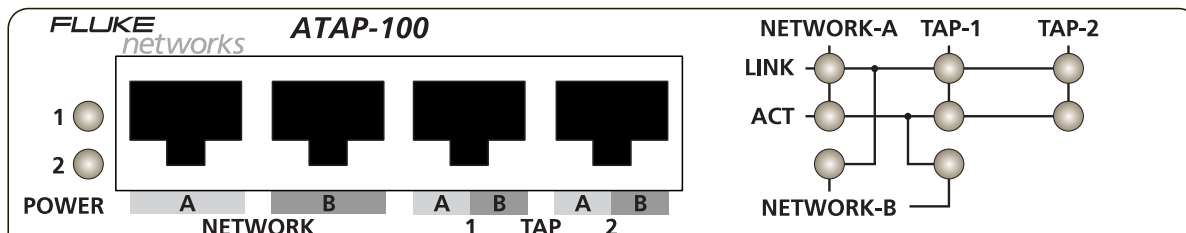

Figure 4. ATAP-100 Link Aggregating In-Line Tap front panel and display

### NOTE

The end-device **LINK** LEDs must indicate **LINK** prior to powering the tap to ensure correct passive tap functionality during loss of power.

### POWER 1 AND POWER 2

Two power supplies are provided. Use of both power supplies is strongly recommended to ensure uninterrupted network monitoring. Connecting the power supplies to different external power source circuits eliminates power as a single-point-of-failure. The **POWER 1** and **POWER 2** LEDs will illuminate, indicating that power 1 and 2 are on, respectively. If either LED fails to illuminate, then there is a defective power source; immediate replacement of the failed power source is required to ensure redundant power integrity.

### NETWORK A AND NETWORK B

These RJ45 connector ports are used for inserting a connection into the network, providing solid network integrity.

## ATAP-100 Series Single Network Port + Dual Tap

### PANEL DESCRIPTION continued

#### TAP 1 A/B AND TAP 2 A/B

These RJ45 connector ports are cabled to the **TAP** Port RJ45 connectors of each network monitoring tool.

#### LINK

The **NETWORK-A LINK** LED will illuminate to indicate that a link is established between the **NETWORK A** connector and **NETWORK A** device. Similarly, the **NETWORK-B LINK** LED will illuminate to indicate that a link is established between the **NETWORK B** connector and **NETWORK B** device. The **TAP 1 LINK** LED will illuminate to indicate that a link is established between the **TAP 1** connector and the NIC on the monitoring device. Similarly, the **TAP 2 LINK** LED will illuminate, indicating that a link is established between the **TAP 2** connector and the NIC on the monitoring device.

#### **NOTE**

*When properly connected, the **NETWORK-A** and **NETWORK-B LINK** LEDs will simultaneously remain illuminated.*

#### ACTIVITY

The **NETWORK A** and **NETWORK B ACT** LEDs will illuminate and blink as data is passed between the **NETWORK A** and **NETWORK B** devices. The **TAP 1 ACT** LED will blink as data is passed to the **TAP 1** monitoring device. The **TAP 2 ACT** LED will blink as data is passed to the **TAP 2** monitoring device.

# ATAP-100 Series Single Network Port + Dual Tap

## TAP FUNCTIONALITY

**Figure 5** illustrates the ATAP-100 Link Aggregating In-Line Tap functional diagram legend, which is located on the rear panel next to the **POWER 1** and **POWER 2** connectors.

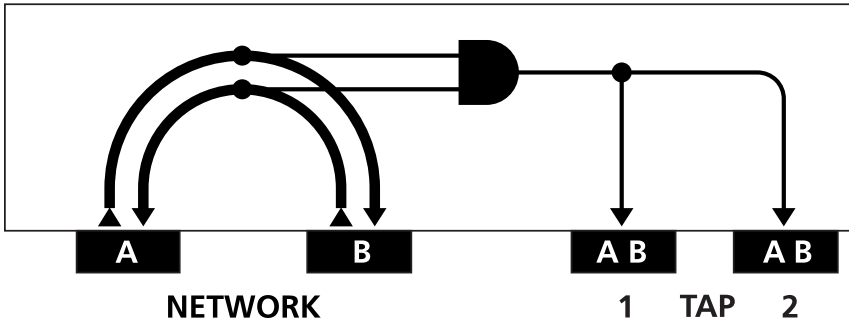

Figure 5. ATAP-100 Link Aggregating In-Line Tap connectivity diagram

## HARDWARE INSTALLATION

Two power supplies are provided. Use both power supplies to ensure uninterrupted monitoring. To connect the ATAP-100 into the network, refer to **Figure 6** and complete the following steps:

### NOTE

End-device **LINK** LEDs must indicate "**LINK**" prior to powering the tap to ensure correct failsafe tap functionality during loss of power.

1. Connect one of the network cables to the ATAP-100 RJ45 port **NETWORK A** connector. The **NETWORK-A LINK** LED will illuminate, indicating that a link is established between the **NETWORK A** connector and the **NETWORK A** device.
2. Connect the other network cable to the ATAP-100 RJ45 port **NETWORK B** connector. The **NETWORK-B LINK** LED will illuminate, indicating that a link is established between the **NETWORK B** connector and the **NETWORK B** device.

### IMPORTANT

When properly connected, the **NETWORK-A** and **NETWORK-B LINK** LEDs will both remain illuminated.

### NOTE

The network link is bidirectional Tx/Rx path-sensitive. Simultaneously illuminated **NETWORK-A** and **NETWORK-B LINK** LEDs will indicate correct connection. If connecting a second network device causes the first **LINK** LED to shut off and both **LINK** LEDs are not illuminated, then the network connection is improperly inverted. Reverse your **NETWORK-A** and **NETWORK-B** connections to establish a proper link.

## ATAP-100 Series Single Network Port + Dual Tap

### HARDWARE INSTALLATION continued

3. Connect the first power supply barrel connector into the **POWER 1** port, and connect the second power supply barrel connector into the **POWER 2** port.

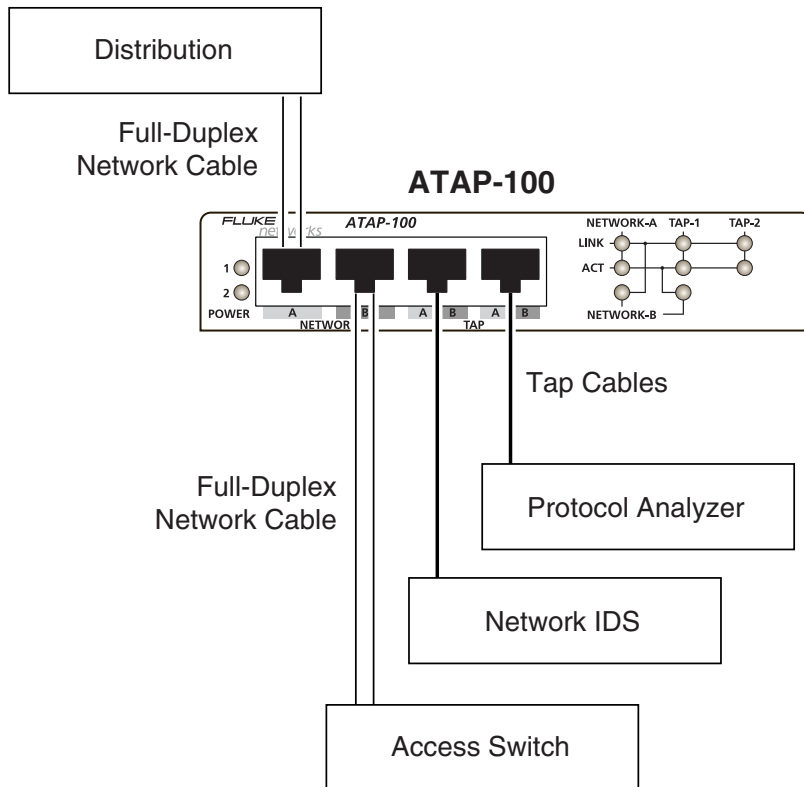

Figure 6. ATAP-100 Link Aggregating In-Line Tap hardware installation

4. Plug the two power supplies into separate external power sources as a means to eliminate power loss as a cause of failure. The **POWER 1** and **POWER 2** LEDs will illuminate, indicating that both power 1 and 2 are active. If either LED fails to illuminate, then there is a defective power source; immediate replacement is required to ensure redundant power integrity. The **NETWORK A** and **NETWORK B ACT** LEDs will illuminate as data is passed between the **NETWORK A** and **NETWORK B** devices.

#### NOTE

Network devices which do not automatically negotiate Tx-Rx pin-out differences between one another — for establishing a link — will typically require a crossover cable. If used, then refer to the table below to connect your devices.

EQUIPMENT – EQUIPMENT	CROSSOVER CABLE CONNECTION
PC – PC	B
PC/ROUTER – SWITCH	none
SWITCH – SWITCH	A

# ATAP-100 Series Single Network Port + Dual Tap

## HARDWARE INSTALLATION continued

**NOTE**

*Do not exceed 100 meters between end-points.*

5. Connect one tap cable from the **TAP 1** port connector into the **IDS** monitoring NIC. The **TAP 1 LINK** LED will illuminate, indicating a link is established between the **TAP 1** connector and the **IDS** monitoring NIC. The **TAP 1 ACT** LED will illuminate as data is passed to the **TAP 1 IDS**.
6. Connect the other tap cable from the **TAP 2** port connector into the protocol analyzer. The **TAP 2 LINK** LED will illuminate, indicating a link is established between the **TAP 2** connector and the analyzer. The **TAP 2 ACT** LED will illuminate as data is passed to the **TAP 2** analyzer.

## GENERAL SPECIFICATIONS

FEATURE	SPECIFICATION
CHANNEL ATAP-100 ATAP-101 ATAP-102 ATAP-103	single 10/100BASE-T in-line single 100BASE-T in-line single 100BASE-T in-line single 10/100BASE-T in-line
CABLE TYPE	CAT 5E
PORT CONNECTIVITY NETWORK A NETWORK B TAP 1 A/B TAP 2 A/B	RJ45 RJ45 RJ45 RJ45
DISTANCE LIMIT	100m max. length between networks
NOMINAL POWER REQUIREMENTS	Single 5V DC @ 1.0A power supply Certified by UL, CUL, and TUV; CE approved
OPERATING TEMPERATURE	0° to 40°C (32° to 104°F)
STORAGE TEMPERATURE	-30° to 65°C (-22° to 149°F)
HUMIDITY	Less than 95% non-condensing
DIMENSIONS	(H) 28mm x (W) 146mm x (D) 146mm (H) 1.10" x (W) 5.75" x (D) 5.75" (includes TAP-RMK-3 bracket)
WEIGHT	unit: 340g (12oz); shipping: 1.81kg (4lbs)

# ATAP-GIG Series Single Network Port + Dual Tap Gigabit

## INTRODUCTION

By using the one of the ATAP-GIG series Link Aggregating In-Line Taps, two monitoring devices can receive combined traffic from both sides of a network conversation. Only one NIC is required by each monitoring device to detect all combined traffic.

**Figure 7** depicts a typical ATAP-GIG Link Aggregating In-Line Tap scenario.

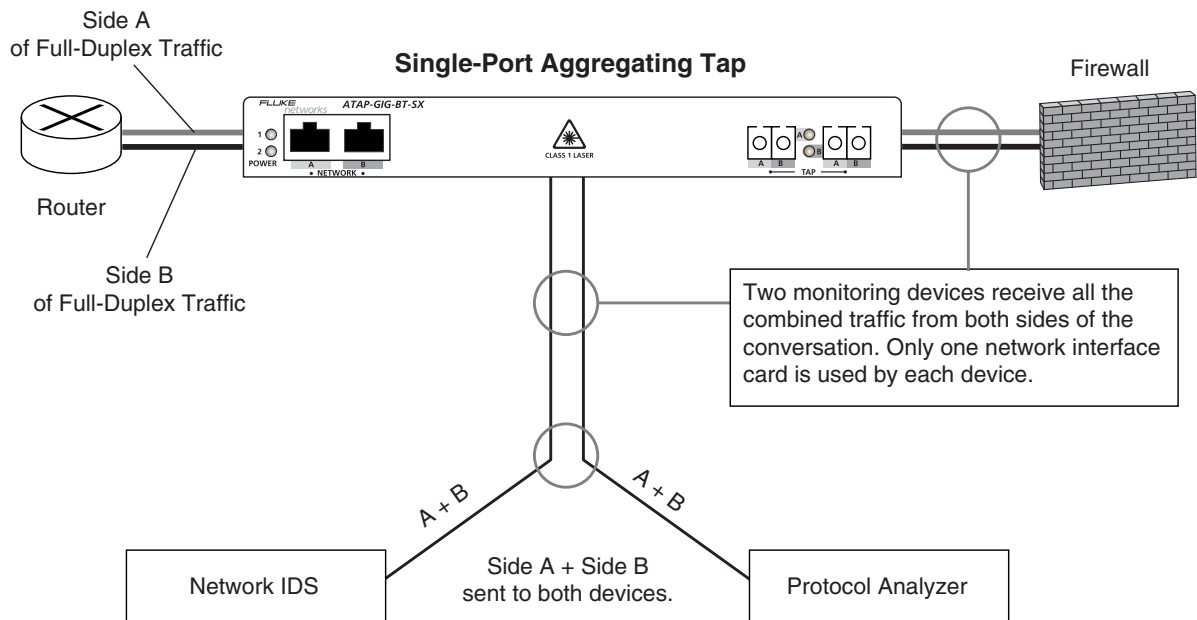

Figure 7. Typical ATAP-GIG series Link Aggregating In-Line Tap application (ATAP-GIG-BT-SX single-port dual-1000BASE-SX tap unit shown here).

# ATAP-GIG Series Single Network Port + Dual Tap Gigabit

## PANEL DESCRIPTION

### POWER 1 AND POWER 2

Two power supplies are provided. Use of both power supplies is strongly recommended to ensure uninterrupted network monitoring. Connecting the power supplies to different external power source circuits eliminates power as a single-point-of-failure. The **POWER 1** and **POWER 2** LEDs will illuminate, indicating that power 1 and 2 are on, respectively. If either LED fails to illuminate, then there is a defective power source; immediate replacement of the failed power source is required to ensure redundant power integrity.

### NETWORK A AND NETWORK B

Depending on your ATAP-GIG series model, these ports — either RJ45 or duplex LC connectors — are used for establishing connections to network segments.

- **RJ45 CONNECTORS.** These have integrated LEDs that display line status and line speed of each port. Refer to **LED Display Codes** below for more details.
- **DUPLEX-LC CONNECTORS.** The LEDs located between the duplex-LC connectors will illuminate as solid green, which indicates that a link is established between the respective **NETWORK** Rx port and network device Tx port.

### TAP (1) A/B AND (2) A/B

Depending on your ATAP-GIG series model, these taps — either RJ45 or duplex-LC connectors — are used for establishing connections to monitoring devices. The RJ45 jacks incorporate integrated LEDs which display the line status and line speed on each port. The **LED Display Codes** table below provides more details. The duplex-LC connectors are used for connecting to tap devices. The LEDs located between the duplex-LC connectors will illuminate as solid green when a link is established between the respective **TAP** Rx port and monitor device Tx port.

### LED DISPLAY CODES integrated on RJ45 ports

CODE	LEFT LED	with link or data RIGHT LED	TRANSFER RATE
LINK	solid green	green	1,000Mbps
DATA	flashing green	orange	100Mbps
N/A	n/a	[off]	10Mbps

# ATAP-GIG Series Single Network Port + Dual Tap Gigabit

## PANEL DISPLAY AND FUNCTIONALITY

### ATAP-GIG-BT-BT



Figure 8. ATAP-GIG-BT-BT Link Aggregating In-Line Tap front panel display

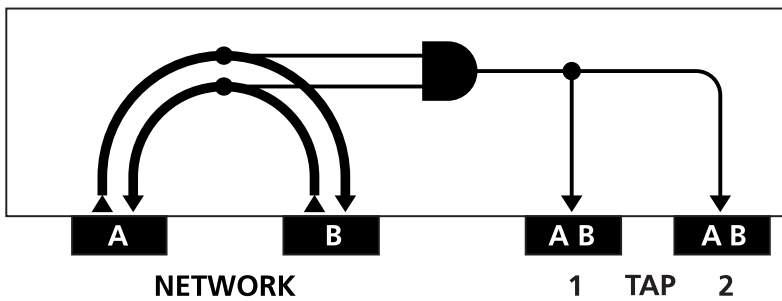

Figure 9. ATAP-GIG-BT-BT Link Aggregating In-Line Tap connectivity diagram

### ATAP-GIG-BT-SX



Figure 10. ATAP-GIG-BT-SX Link Aggregating In-Line Tap front panel display

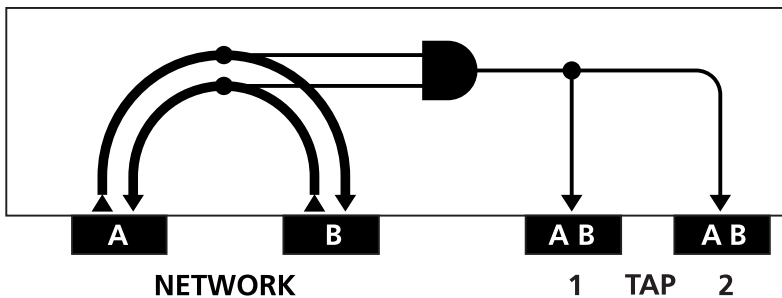

Figure 11. ATAP-GIG-BT-SX Link Aggregating In-Line Tap connectivity diagram

# ATAP-GIG Series Single Network Port + Dual Tap Gigabit

## PANEL DISPLAY AND FUNCTIONALITY continued

### ATAP-GIG-SX-BT



Figure 12. ATAP-GIG-SX-BT Link Aggregating In-Line Tap front panel display

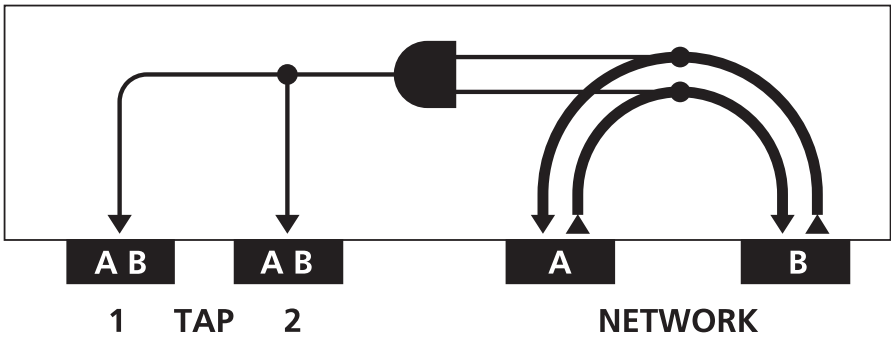

Figure 13. ATAP-GIG-SX-BT Link Aggregating In-Line Tap connectivity diagram

### ATAP-GIG-SX-SX



Figure 14. ATAP-GIG-SX-SX Link Aggregating In-Line Tap front panel display

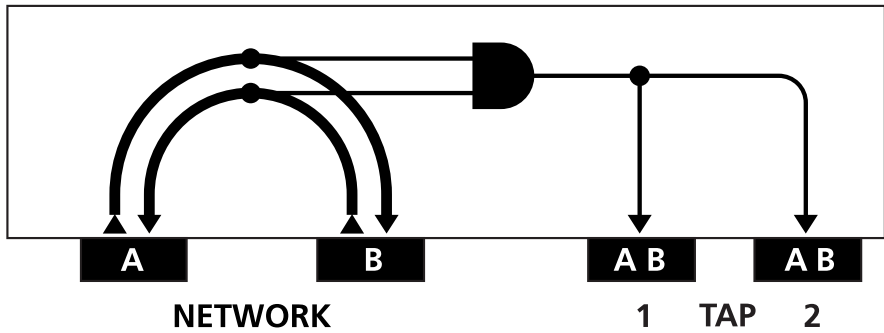

Figure 15. ATAP-GIG-SX-SX Link Aggregating In-Line Tap connectivity diagram

# ATAP-GIG Series Single Network Port + Dual Tap Gigabit

## HARDWARE INSTALLATION

The following instructions illustrate a typical hardware installation for the ATAP-GIG-SX-BT Link Aggregating In-Line Tap, as shown by the previous example in **Figure 15** and the example below in **Figure 16**. Installation for other ATAP-GIG series models are similar.

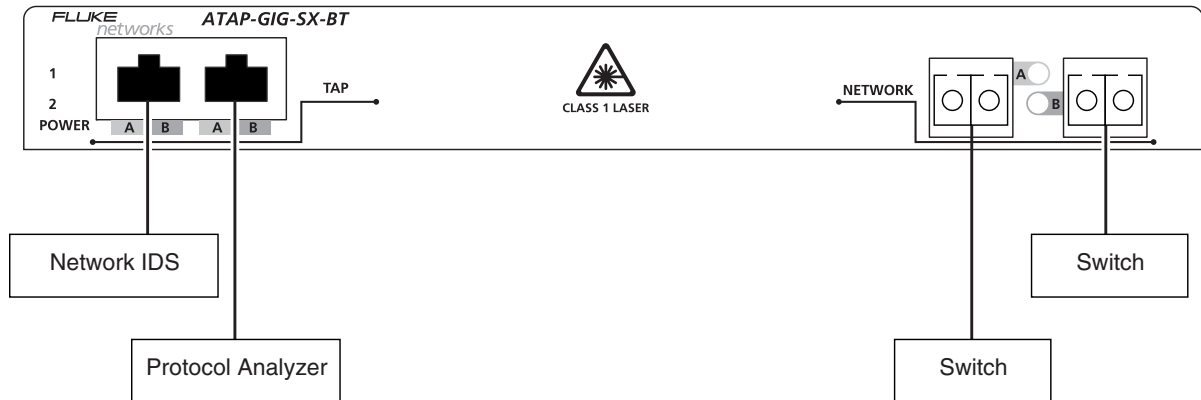

Figure 16. ATAP-GIG-SX-BT Link Aggregating In-Line Tap hardware installation diagram

### NOTE

End-device **LINK** LEDs must indicate "**LINK**" prior to powering the tap to ensure correct failsafe tap functionality during loss of power.

1. Connect network cables to the ATAP-GIG-SX-BT **NETWORK** duplex-LC ports. The **NETWORK** LED will illuminate as solid green, indicating that a Tx/Rx path link is established between the network devices. When both **NETWORK** port Tx/Rx paths are completed, both **NETWORK** LEDs will illuminate as solid green. The LED will flash green when data is passed from the respective network device to the network port.
2. Two external power supplies are provided. Use the second power supply to ensure uninterrupted network monitoring. Connect both power supply barrel connectors on the ATAP-GIG-SX-BT into the **POWER 1** and **POWER 2** ports, respectively. Plug the power supplies into separate external power sources to eliminate power as a single-point-of-failure. The **POWER 1** and **POWER 2** LEDs will illuminate, indicating that both power 1 and 2 are on. If either LED fails to illuminate, then there is a defective power source; immediate replacement of the failed power source is required to ensure redundant power integrity.
3. Connect your monitor cables to the ATAP-GIG-SX-BT **TAP** RJ45 ports. The **TAP** RJ45 left LED (on ATAP-GIG-BT-SX units, the dual-LC **TAP** LED) will illuminate as solid green, indicating that a link is established between the respective **TAP** port and the tap device (or monitor device Tx port on ATAP-GIG-BT-SX units). Refer to the RJ45 **LED Display Codes** table on page 15. The LED will flash green when data is passed from the respective network device to the network port.

### NOTE

When installing an ATAP-GIG-BT-BT or ATAP-GIG-BT-SX Link Aggregating In-Line Tap, follow these hardware installation steps, as appropriate, in lieu of the ATAP-GIG-SX-BT Link Aggregating In-Line Tap. Since ATAP-GIG series installations are relatively similar, you can simply connect monitor cables to tap ports and network cables to network ports.

# ATAP-GIG Series Single Network Port + Dual Tap Gigabit

## GENERAL SPECIFICATIONS

FEATURE	SPECIFICATION
CHANNEL ATAP-GIG-BT-BT ATAP-GIG-BT-SX ATAP-GIG-SX-BT ATAP-GIG-SX-SX ATAP-GIG-LX-BT	single 10/100/1000BASE-T in-line single 10/100/1000BASE-T in-line single 1000BASE-SX fiber in-line single 1000BASE-SX fiber in-line single 1000BASE-LX fiber in-line
CABLE TYPE COPPER FIBER	CAT 5E SX [50 micron or 62 micron]; LX [9 micron]
PORT CONNECTIVITY NETWORK A NETWORK B TAP (1) A/B TAP (2) A/B	RJ45 [copper] / duplex-LC [fiber] RJ45 [copper] / duplex-LC [fiber] RJ45 [copper] / duplex-LC [fiber] RJ45 [copper] / duplex-LC [fiber]
DISTANCE LIMIT COPPER FIBER	100m max. length between networks; 1m between taps [varies by cable type]
NOMINAL POWER REQUIREMENTS	Two external 5V DC at 1.0A power supplies Certified by UL, CUL, and TUV; CE approved
OPERATING TEMPERATURE	0° to 40°C (32° to 104°F)
STORAGE TEMPERATURE	-30° to 65°C (-22° to 149°F)
HUMIDITY	Less than 95% non-condensing
DIMENSIONS	(H) 28mm x (W) 222mm x (D) 146mm (H) 1.10" x (W) 8.75" x (D) 5.75" (includes TAP-RMK-2 panel bracket)
WEIGHT	unit: 340g (12oz); shipping: 2.27kg (5lbs)

# ATAP-2000 Series Dual Network Port + Dual Tap Gigabit

## INTRODUCTION

The ATAP-2000 series provides a single turnkey solution for 24x7 monitoring of redundant, failover, two-link Gig Etherchannel and asymmetric Gigabit network segments. It provides the power and flexibility of the ATAP-GIG series Ethernet Tap with the capability of monitoring two network segments simultaneously — aggregating the data and sending a single copy to your connected network devices.

**Figure 17** depicts a typical ATAP-2000 Link Aggregating In-Line Tap scenario.

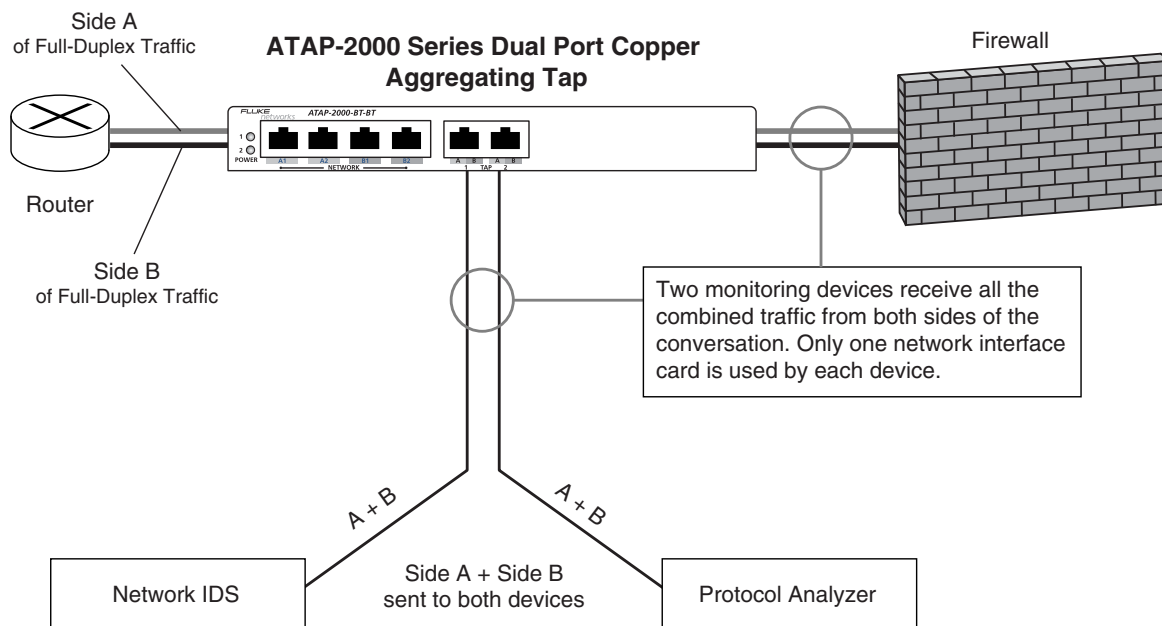

Figure 17. Typical ATAP-2000 series Link Aggregating In-Line Tap application (ATAP-2000-BT-BT dual-port dual-1000BASE-T tap unit shown here).

## APPLICATION

In a typical ATAP-2000 series Link Aggregating In-Line Tap scenario, the tap is inserted into a pair of Gigabit Ethernet segments where your monitoring or analysis equipment is connected. No other configuration is required.

Asymmetric routing, Gig Etherchannel and load-balanced environments use multiple paths to send and reassemble data as it reaches its destination. The ATAP-2000 series Link Aggregating In-Line Tap makes monitoring and analyzing multiple data paths less of a challenge. The ATAP-2000 series aggregates both streams of data it receives. With this aggregating feature, you can collect whatever amount of data you need with as little as one tool and one trace file.

Redundant networking systems — in the event of cable or hardware failure — no longer require more than one device to receive data from both network segments. With the ATAP-2000 series, you may leave your monitoring and analysis tools connected continuously with no need to manually switch or move connections. Should one network segment fail, the ATAP-2000 series will continue to collect data from your secondary segment without interruption.

# ATAP-2000 Series Dual Network Port + Dual Tap Gigabit

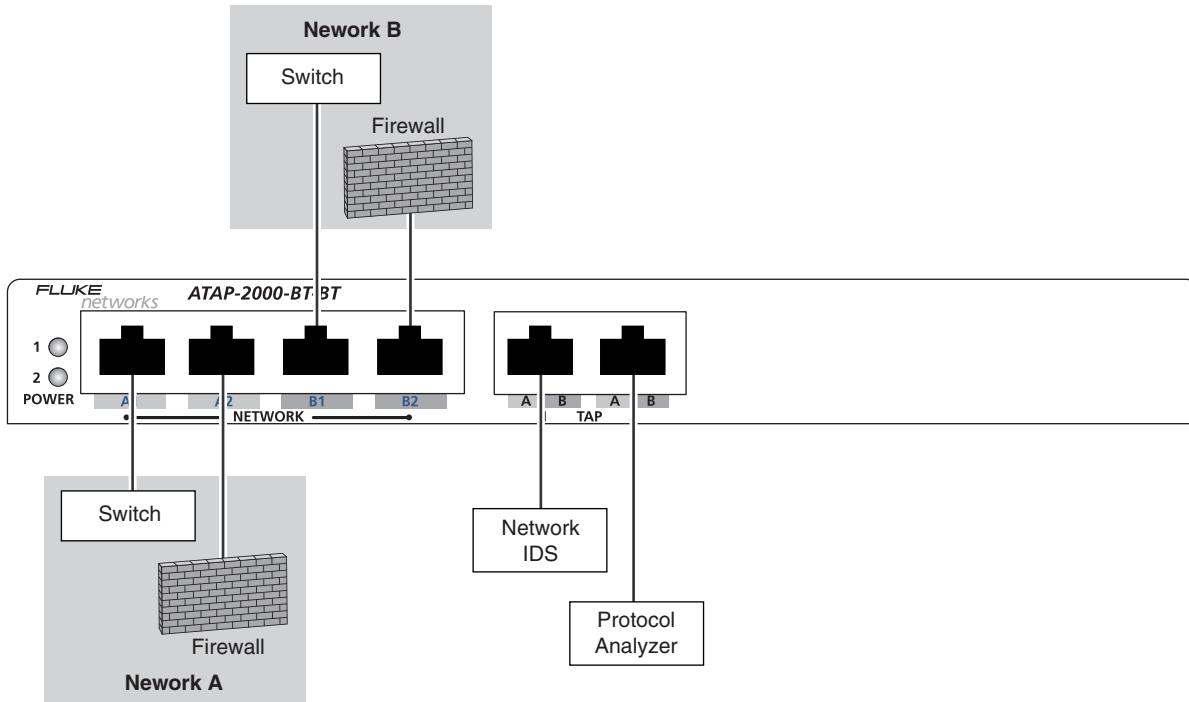

Figure 18. ATAP-2000-BT-BT Link Aggregating In-Line Tap hardware installation

Further, the ATAP-2000 series is equipped with a second tap port to help manage network resources. With an extra tap port, two devices (i.e., an analyzer and an intrusion detection device) can receive the same full-duplex transmission, averting contention for access to your network link. You may also keep two identical devices connected to the ATAP-2000 series in the event that one device fails; the other will continue to collect data from both segments without interruption.

## PANEL DESCRIPTION

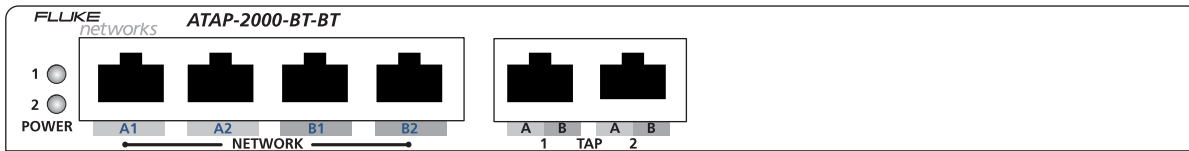

Figure 19. ATAP-2000-BT-BT Link Aggregating In-Line Tap front panel display

## POWER 1 AND POWER 2

Two power supplies are provided with the ATAP-2000 series Link Aggregating In-Line Tap. It is strongly recommended to use both power supplies in redundant capacity to ensure uninterrupted network monitoring. To provide redundant, fail-safe power, you must connect the second power supply to a separate external power source circuit. The **POWER 1** and **POWER 2** LEDs will illuminate, indicating that power 1 and 2 are on, respectively. If either LED fails to illuminate, then there is a defective power source; immediate replacement of the failed power source is required to ensure redundant power integrity.

# ATAP-2000 Series Dual Network Port + Dual Tap Gigabit

## NETWORK PORTS A1, A2, B1 AND B2

Depending on your ATAP-2000 series model, these ports — either RJ45 or duplex LC connectors — are used for establishing connections to network segments.

- **RJ45 CONNECTORS.** These have integrated LEDs that display line status and line speed of each port. Refer to the **LED Display Codes** on page 15 for more details.
- **DUPLEX-LC CONNECTORS.** The LEDs located between the duplex-LC connectors will illuminate as solid green, which indicates that a link is established between the respective **NETWORK** Rx port and network device Tx port.

## TAP PORTS (1) A/B AND (2) A/B

Depending on your ATAP-2000 series model, these taps — either RJ45 or duplex-LC connectors — are used for establishing connections to monitoring devices. The RJ45 jacks incorporate integrated LEDs which display the line status and line speed on each port. The **LED Display Codes** table on page 15 provides more details. The duplex-LC connectors are used for connecting to tap devices. The LEDs located between the duplex-LC connectors will illuminate as solid green when a link is established between the respective **TAP** Rx port and monitor device Tx port.

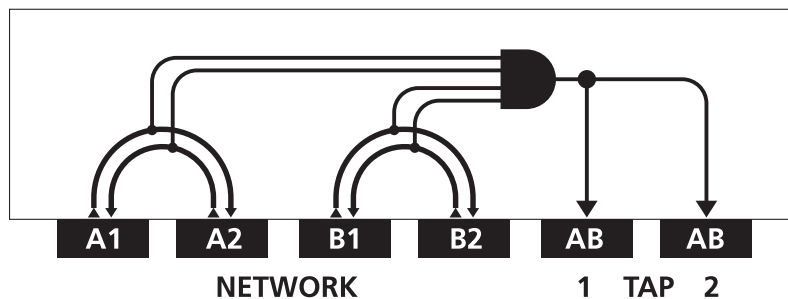

Figure 20. ATAP-2000-BT-BT Link Aggregating In-Line Tap connectivity diagram

## HARDWARE INSTALLATION

Two power supplies are provided. Use both power supplies to ensure uninterrupted monitoring. Use the following steps to install your ATAP-2000 series Link Aggregating In-Line Tap.

### NOTE

End-device LINK LEDs must indicate **"LINK"** prior to powering the tap to ensure correct failsafe tap functionality during loss of power.

1. Connect network cables to the ATAP-2000 series **NETWORK** ports. The **NETWORK** left LED will illuminate as solid green, indicating that a link is established between the **NETWORK** port and your network device. Refer to the RJ45 **LED Display Codes** table on page 15 for more details.

## ATAP-2000 Series Dual Network Port + Dual Tap Gigabit

### HARDWARE INSTALLATION continued

- Two external power supplies are provided. Use the second power supply to ensure uninterrupted network monitoring. Connect both power supply barrel connectors on the ATAP-2000 series into the **POWER 1** and **POWER 2** ports, respectively. Plug the power supplies into separate external power sources to eliminate power as a single-point-of-failure. The **POWER 1** and **POWER 2** LEDs will illuminate, indicating that both power 1 and 2 are on. If either LED fails to illuminate, then there is a defective power source; immediate replacement of the failed power source is required to ensure redundant power integrity.
- Connect monitor cables to the ATAP-2000 series **TAP** ports. The **TAP** LED will illuminate as solid green, indicating that a link is established between the respective **TAP** port and monitor device. Refer to the **LED Display Codes** table on page 15 for details on RJ45 LED signal indicators.

### GENERAL SPECIFICATIONS

FEATURE	SPECIFICATION
CHANNEL ATAP-2000-BT-BT ATAP-2000-SX-SX ATAP-2000-LX-SX ATAP-2001-BT-BT	dual 10/100/1000BASE-T in-line dual 1000BASE-SX fiber in-line dual 1000BASE-LX fiber in-line dual 1000BASE-T in-line
CABLE TYPE COPPER FIBER	CAT 5E SX [50 micron or 62 micron]; LX [9 micron]
PORT CONNECTIVITY NETWORK A1, A2 NETWORK B1, B2 TAP (1) A/B TAP (2) A/B	RJ45 [copper] / duplex-LC [fiber] RJ45 [copper] / duplex-LC [fiber] RJ45 [copper] / duplex-LC [fiber] RJ45 [copper] / duplex-LC [fiber]
DISTANCE LIMIT	100m max. length between networks; 1m between taps
NOMINAL POWER REQUIREMENTS	Two external 5V DC at 1.0A power supplies Certified by UL, CUL, and TUV; CE approved
OPERATING TEMPERATURE	0° to 40°C (32° to 104°F)
STORAGE TEMPERATURE	-30° to 65°C (-22° to 149°F)
HUMIDITY	Less than 95% non-condensing
DIMENSIONS	(H) 28mm x (W) 222mm x (D) 146mm (H) 1.10" x (W) 8.75" x (D) 5.75" (includes TAP-RMK-2 panel bracket)
WEIGHT	unit: 340g (12oz); shipping: 2.27kg (5lbs)

## Care and Maintenance

Each Link Aggregating In-Line Tap is designed to be maintenance free. Treat it with care to ensure the best performance. The suggestions below will help you fulfill the obligations of the warranty and enjoy the tap for many years.

### **AVOIDING ROUGH HANDLING**

Although each Link Aggregating In-Line Tap model can absorb shock and vibration, avoid dropping it. If you must ship the tap, use the original packaging or the ruggedized transit case.

### **CLEANING CAREFULLY**

To clean your Link Aggregating In-Line Tap, use a soft, slightly damp cloth. To remove any stains, use a mild soap. Never use detergents, solvents, or abrasive cleaners on the tap.

### **PROVIDING ADEQUATE VENTILATION**

Always place the Link Aggregating In-Line Tap in an area where there is sufficient space in front and behind the unit to provide adequate ventilation.

### **SAFETY INFORMATION**

To avoid possible electric shock or personal injury, the following general safety precautions must be observed during all phases of operation, service, or repair of your Link Aggregating In-Line Tap. Failure to comply with these precautions or with specific warnings in this guide violates the safety standards of design, manufacture and intended use of the tap. Fluke Networks assumes no liability for the customer's failure to comply with these requirements.

### **WARNINGS**

If this product is used in a manner not specified by the manufacturer, the protections provided by the product may be impaired. Do not use the tap if it is damaged. Before using, inspect the case. Look for cracked or missing case parts. Pay particular attention to the insulation surrounding the connectors.

Do not operate the tap around explosive gas, vapor or dust. When servicing the tap, use specified replacement parts only. Do not connect a telephone line to the tap. Provide adequate ventilation in front of and behind the tap.

### **SERVICE AND ADJUSTMENT**

Service and adjustment of your Link Aggregating In-Line Tap should be performed by trained Fluke Networks service personnel only. If you experience a problem with the tap, visit the Fluke Networks website at <http://www.flukenetworks.com>, send email to [support@flukenetworks.com](mailto:support@flukenetworks.com), or contact your nearest Fluke Networks Service Center to report the problem (see **Contacting Fluke Networks** for a list of telephone numbers).

If the tap requires repair, service center personnel will provide you with shipping information and repair prices. If the tap is covered under warranty, it will be promptly repaired or replaced (at Fluke Networks' option) and returned to you, postage paid, at no charge. See the registration card for warranty terms. If the warranty has lapsed, Fluke Networks will repair the tap for a