



99 Washington Street
Melrose, MA 02176
Phone 781-665-1400
Toll Free 1-800-517-8431

FLUKE®



Visit us at www.TestEquipmentDepot.com

77 Series III

Multimeter

Service Manual

PN 800604

November 1998 Rev.1, 11/99

© 1998,1999 Fluke Corporation. All rights reserved. Printed in U.S.A.

All product names are trademarks of their respective companies.

Table of Contents

Chapter	Title	Page
1	Introduction and Specifications	1-1
	1-1. Introduction	1-3
	1-2. Organization of the Service Manual	1-3
	1-3. Conventions	1-4
	1-4. Specifications	1-4
2	Theory of Operation	2-1
	2-1. Introduction	2-3
	2-2. Functional Block Description	2-3
	2-3. Detailed Description	2-3
	2-4. Voltage Signal Conditioning	2-3
	2-5. Current Conditioning	2-4
	2-6. Ohms	2-4
	2-7. Additional Circuitry	2-4
	2-8. AC Converter	2-5
	2-9. Active Filter	2-5
	2-10. Rotary Switch	2-5
	2-11. A/D Conversion	2-5
3	Maintenance	3-1
	3-1. Introduction	3-3
	3-2. PCA Access and General Maintenance	3-3
	3-3. Display Access	3-4
	3-4. Cleaning	3-4
	3-5. Performance Test	3-7
	3-6. Initial Procedure	3-7
	3-7. DC Voltage Test	3-7
	3-8. AC Voltage Test	3-8
	3-9. Resistance Test	3-8

3-10.	Diode Test	3-9
3-11.	DC mA Test	3-10
3-12.	DC Amps Test	3-11
3-13.	Calibration	3-11
3-14.	Troubleshooting	3-11
3-15.	Supplemental Troubleshooting Procedures	3-13
3-16.	Checking the Crystal Oscillator	3-13
3-17.	Checking The Reference Voltage	3-13
3-18.	Checking Display Drive Voltage	3-13
3-19.	Checking Beeper Drive Signal	3-13
3-20.	Tracing the VDC Signal Path	3-13
4	List of Replaceable Parts.....	4-1
4-1.	Introduction	4-3
4-2.	How to Obtain Parts	4-3
4-3.	Newer Instruments	4-3
4-4.	Service Centers	4-3
4-5.	Manual Status Information	4-4
4-6.	Parts Lists	4-4
5	Schematic Diagrams	5-1

List of Tables

Table	Title	Page
1-1.	Specifications	1-5
2-1.	S1 Function Codes.....	2-6
3-1.	Recommended Test Equipment.....	3-3
3-2.	DC Voltage Test.....	3-8
3-3.	AC Voltage Test.....	3-8
3-4.	Resistance Test.....	3-10
3-5.	DC mA Test.....	3-11
3-6.	DC Amps Test.....	3-11
4-1.	Final Assembly.....	4-5
4-2.	A1 Main PCA.....	4-7
5-1.	Abbreviations	5-3

List of Figures

Figure	Title	Page
2-1.	Overview	2-3
2-2.	AC and A/D Converter	2-7
3-1.	Assembly Details	3-6
3-2.	Troubleshooting Tree	3-12
4-2.	A1 Main PCA	4-9
5-1.	A1 Main PCA	5-4

OPERATOR SAFETY INFORMATION



This instrument has been designed and tested in accordance with IEC Publication 348, Safety Requirements for Electronic Measuring Apparatus. This manual contains information and warnings which have to be followed by the user to ensure safe operation and to retain the instrument in safe condition.

Warning statements identify conditions or practices that could result in personal injury or loss of life.

Caution statements identify conditions or practices that could result in damage to the equipment or other property.

- Never use the meter if the meter or test leads look damaged.
- Always turn off power to the circuit before cutting, unsoldering, or breaking the circuit. Small amounts of current can be dangerous.
- Never measure resistance in a circuit when power is applied to the circuit.
- Never touch the probes to a voltage source when the test leads are plugged into the 10A or 300 mA input jack.
- Never apply more than 1000V dc or ac rms (sine) between any input jack and earth ground.
- Always be careful when working with voltages above 60V dc or 30V ac rms. Such voltages pose a shock hazard.
- Always keep your fingers behind the finger guards on the probe when making measurements.
- Always use a high voltage probe to measure voltage if the peak voltage might exceed 1000V.

Symbols Marked on Equipment

-  DANGER — High Voltage
-  Attention — refer to the manual. This symbol indicates that information about the usage of a feature is contained in the manual.
-  Fuse information

Use the Proper Fuse

To avoid fire hazard, use only the fuse identical in type, voltage rating, and current rating as specified on the case bottom fuse rating label.

Do Not Remove Cover

Always operate the meter with case top and bottom properly assembled.

Access procedures and the warnings for such procedures are contained in this Service Manual. Service procedures are for qualified service personnel only.

Do Not Attempt to Operate if Protection May be Impaired

If the meter appears damaged or operates abnormally, protection may be impaired. Do not attempt to operate it. When in doubt, have the instrument serviced.

Chapter 1

Introduction and Specifications

	Contents	Page
1-1.	Introduction.....	1-3
1-2.	Organization of the Service Manual	1-3
1-3.	Conventions	1-4
1-4.	Specifications.....	1-4

1-1. Introduction

This manual presents service information for the Fluke 77 Series III Multimeter. The manual includes a theory of operation, general maintenance procedures, performance tests, calibration procedures, troubleshooting information, a list of replaceable parts, and schematic diagrams.

A meter under warranty will be promptly repaired or replaced (at Fluke's option) and returned at no charge. See the registration card for warranty terms. To locate an authorized service center, visit us on the World Wide Web: www.fluke.com or call using any of the phone numbers listed below:

USA: 1-888-99-FLUKE (1-888-993-5853)
Canada: 1-800-36-FLUKE (1-800-363-5853)
Europe: +31 402-678-200
Japan: +81-3-3434-0181
Singapore: +65-738-5655
Anywhere in the world: +1-425-446-5500

1-2. Organization of the Service Manual

The following descriptions briefly describe each chapter in the manual.

Chapter 1 Introduction and Specifications

This chapter describes use of the Service Manual and application of special terminology (conventions) to describe the meter's circuitry. A complete set of specifications appears at the end of this chapter.

Chapter 2 Theory of Operation

This chapter first categorizes instrument circuitry into functional blocks, with a description of each block's role in overall operation. A detailed circuit description is then given for each block. These descriptions explore operation to the component level and fully support troubleshooting and repair procedures defined in Section 3.

Chapter 3 Maintenance

Provides complete maintenance information, from general maintenance and cleaning instructions to detailed troubleshooting and repair procedures to the component level. Troubleshooting and repair procedures rely heavily on both the Theory of Operation presented in Chapter 2 and the Schematic Diagrams shown in Section 5.

Chapter 4 List of Replaceable Parts

Includes parts lists for all standard assemblies. Information on how and where to order parts is also provided.

Chapter 5 Schematic Diagrams

Includes schematic for the A1 Main PCA.

1-3. Conventions

Through the manual, certain notational conventions are used. A summary of these conventions follow:

- Instrument Reference

The Fluke 77 Series III Multimeter is also referred to throughout this manual as “the meter”.

- Printed Circuit Assembly

The term “pca” is used to represent a printed wiring board and its attached parts.

- Circuit Nodes

Individual pins or connections on a component are specified by a dash (-) following the component reference designator. For example, pin 19 of U30 would be U30-19.

- User Notation

Generally, push buttons, function positions, input terminals, and display notation are presented in this manual as they are seen on the meter.

Special terms (mnemonics) used in text descriptions of meter circuitry correspond to terms used on the schematic diagrams in Chapter 5.

1-4. Specifications

Specifications for the meters are presented in Table 1-1.

Table 1-1. Specifications





Maximum Voltage Between any Terminal and Earth Ground	Rated voltage
Display	Digital: 3,200 counts, updates 2.5/sec Analog: 31 segments, updates 25/sec
Response Time of Digital Display	V ac < 2 s V dc < 1 s Ω < 1s to 320 k Ω , < 2s to 3.2 M Ω , < 10 s to 32 M Ω
Operating Temperature	0°C to 50°C
Storage Temperature	-40°C to 60°C
Temperature Coefficient	0.1 x (specified accuracy)/°C (<18°C or >28°C)
Electromagnetic Compatibility In RF field of 3 V/m on all functions.	Total accuracy = Specified accuracy + 0.1% of range.
Relative Humidity	
except 32 M Ω range	0% to 90% (0°C to 35°C) 0% to 70% (35°C to 50°C)
32 M Ω range only	0% to 80% (0°C to 35°C) 0% to 70% (35°C to 50°C)
Altitude	Operating: 2000 meters Storage: 12,000 meters
Battery Type	9 V NEDA 1604 or 6F22 or 006P, or NEDA 1604A or 6LR61
Battery Life	2000 hrs typical with alkaline 1600 hrs typical with carbon zinc
Continuity Beeper	4096 Hz
Shock, Vibration	per MIL-T-PRF 28800F Class III, Sinusoidal, Non Operating
Size (H x W x L)	3.7 cm x 8.9 - 7.8 cm x 19 cm (1.5 in x 3.5 - 3.1 in x 7.49 in)
Weight	365 g (12.9 oz)
Safety	600 V CAT III and 1000 V CAT II per ANSI/ISA S82.01-1994, EN 61010-1: 1993, CSA C22.2 No 1010.1-92, UL 3111-1.
EMC Regulations	EN 61326-1 1997.
Certifications/Listings	
    	

Table 1-1. Specifications (cont)

Function	Range	Accuracy	
\bar{V}	3.200 V	$\pm(0.3\%+1)$	
	32.00 V	$\pm(0.3\%+1)$	
	320.0 V	$\pm(0.3\%+1)$	
	1000 V	$\pm(0.4\%+1)$	
$m\bar{V}$	320.0 mV	$\pm(0.3\%+1)$	
\tilde{V} (45 to 500 Hz, 3.2 V range. Other ranges 45 to 1 kHz)	3.200 V	$\pm(2\%+2)$	
	32.00 V	$\pm(2\%+2)$	
	320.0 V	$\pm(2\%+2)$	
	1000 V	$\pm(2\%+2)$	
Ω	320.0 Ω	$\pm(0.5\%+3)$	
	3200 Ω	$\pm(0.5\%+1)$	
	32.00 k Ω	$\pm(0.5\%+1)$	
	320.0 k Ω	$\pm(0.5\%+1)$	
	3.200 M Ω	$\pm(0.5\%+1)$	
	32.00 M Ω	$\pm(2.0\%+1)$	
$\rightarrow \rightarrow \rightarrow \rightarrow$)	2.0 V	$\pm(1\% \text{ typical})$	
Function	Range	Accuracy	Burden Voltage (typical)
\tilde{A} (45 Hz to 1 kHz)	32.00 mA,	$\pm(2.5\%+2)$ $\pm(2.5\%+2)$	6 mV/mA
	320.0 mA		50 mV/A
	10.00 A *		
\bar{A}	32.00 mA,	$\pm(1.5\%+2)$ $\pm(1.5\%+2)$	6 mV/mA
	320.0 mA		50 mV/A
	10.00 A *		

* 10 A continuous, 20 A for 30 seconds maximum.

Overload protection for all functions and ranges: Rated voltage.

Function	Input Impedance (Nominal)		
\bar{V} , $m\bar{V}$, \tilde{V}	>10 M Ω , <50 pF		
	Common Mode Rejection Ratio (1 kΩ Unbalanced)	Normal Mode Rejection	
\bar{V} , $m\bar{V}$	>120 dB at dc, 50 Hz, or 60 Hz	>60 dB at 50 Hz or 60 Hz	
\tilde{V}	>60 dB dc to 60 Hz		
	Open Circuit Test Voltage	Full Scale Voltage	
		To 3.2 MΩ	32 MΩ
Ω	<3.1 V dc <2.8 V dc (typical)	<440 mV dc <420 mV dc (typical)	<1.4 V dc <1.3 V dc (typical)
	Open Circuit Test Voltage	Full Scale Voltage	
$\rightarrow + \parallel$)	<3.1 V dc	2.0 V dc	
	Short Circuit Current (typical)		
Ω	300 μ A		
$\rightarrow + \parallel$)	400 μ A		
$\rightarrow +$	V_F	Current (typical)	
	0.0 V	0.4 mA	
	0.6 V	0.3 mA	
	1.2 V	0.2 mA	
	2.0 V	0.1 mA	

Chapter 2

Theory of Operation

	Contents	Page
2-1.	Introduction.....	2-3
2-2.	Functional Block Description	2-3
2-3.	Detailed Description	2-3
2-4.	Voltage Signal Conditioning	2-3
2-5.	Current Conditioning.....	2-4
2-6.	Ohms.....	2-4
2-7.	Additional Circuitry.....	2-4
2-8.	AC Converter	2-4
2-9.	Active Filter	2-5
2-10.	Rotary Switch.....	2-5
2-11.	A/D Conversion.....	2-5

2-1. Introduction

This chapter contains a brief overview of the 77 Series III Multimeter, followed by a more detailed explanation of operation.

2-2. Functional Block Description

The heart of the instrument consists of a two-chip CMOS system: U1, a primarily analog IC, and U2, a calculator-style microcomputer (see Figure 2-1).

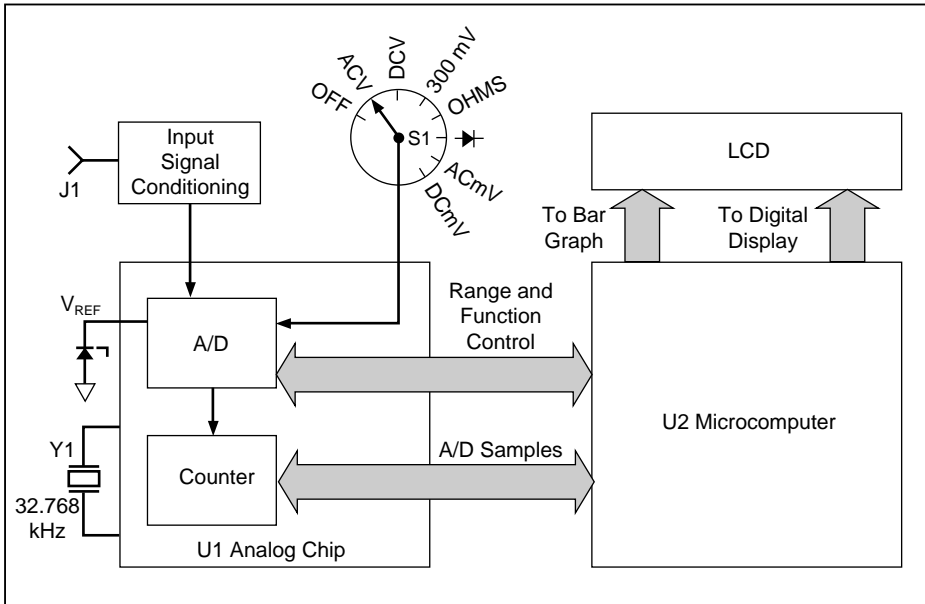

aaa01f.eps

Figure 2-1. Overview

2-3. Detailed Description

The following paragraphs describe the 77 Series III Multimeter in more detail. While reading this description, refer to the schematic diagram in Chapter 5.

2-4. Voltage Signal Conditioning

Input divider Z1 and dc blocking capacitor C1 make up an input voltage signal conditioning circuit.

The pins of Z1 are used as follows:

Z1-PIN NUMBER	FUNCTION
1	input
3	3.2V range tap
4	32V range tap
5	320V range tap
6	1000V dc/750V ac range tap

Overvoltage protection is provided by R1, RV1, RV2, RV3, and RT1.

RT1 is a thermistor that normally has about 1 k Ω of resistance, but increases to very high impedance as it heats up with an overload voltage. R1 provides current limiting for the input until RT1 heats up. In an overload condition, RV1, RV2, and RV3 clamp the voltage at the switch to approximately 2000V.

2-5. Current Conditioning

Current input conditioning is provided by R6, R7, R5 and R13. R6 and R7 develop input voltage from the applied current. R5 and R13 act as a voltage divider for the 300-mA range. F1 protects the mA circuitry; F3 protects the 10A circuitry.

2-6. Ohms

When the ohms function is selected, the meter compares the unknown resistance at J1 with the reference resistors in Z1.

Input protection for the ohms ranges consists of Q1, Q2, Q3, R1, R2, R3, R4, and RT1. Q1 and Q2 serve as back-to-back zener diodes which limit the input to between 7 and 9V. Also, R2, R3, and R4 limit current, and Q3 clamps pin 29 of U1 to approximately 2.5V.

2-7. Additional Circuitry

In addition to the above circuitry, the following circuitry is also used in the Series II meters: AC Converter, Active Filter, Rotary Switch, and A/D Conversion.

2-8. AC Converter

The ratio of R17 and R18 determines ac voltage and current accuracy (see Figure 2-2, AC and A/D Converter), and C11 is the averaging capacitor for the half-wave ac converter portion of U1.

2-9. Active Filter

An active filter that includes R9, R10, C5, and C6 is located in U1. Conditioned input signals are passed through the active filter in route to the a/d converter section of U1. (See Figure 2-2, AC and A/D Converter.)

The clock frequency for the digital portion of the circuit is a function of 32.768-kHz crystal Y1. Y1, C12, C15, and amplifiers in U1 make up the oscillator circuit.

2-10. Rotary Switch

Rotary switch S1 FRONT selects and routes the input signals. Function codes for switch S1 REAR are shown in Table 2-1. Range switch S2 signals the microcomputer U2 for the manual ranging and automatic Touch Hold® function.

CR1 acts as protection for U1 if the battery is installed backwards. C2 is part of the power-on reset for microcomputer U2.

2-11. A/D Conversion

Analog-to-digital (a/d) conversion is accomplished within U1 using a modified dualslope a/d converter circuit. (See Figure 2-2, AC and A/D Converter.)

Since the a/d conversion process is essentially a dual slope method, two voltages are required to complete a measurement cycle. One is the unknown input and the other is the reference voltage.

Conditioned input signals are routed to the a/d converter in U1, where they are integrated. The reference voltage developed by reference supply VR1, R15, R16, and R8 is routed to the a/d converter in U1, where it is used for the integrate reference (de-integrate) portions of the measurement cycle.

C7 stores offsets of the buffer, integrator, and comparator amplifiers of the a/d converter. The gain of the buffer is determined by the resistors of Z1 between pins 8, 9, and 10. C8 is the integrator capacitor.

A series of 10 minor cycle conversions occurs without taking time for an autozero phase between the conversions. These minor cycle conversions, or samples, occur at a rate of 25 per second, and are used to provide the fast response bar-graph display and fast autoranging.

New samples are taken every 40 ms. Ten samples are summed to produce a full-resolution digital display, with full scale greater than 3200 counts. A 50-ms autozero phase occurs following every 10 sample sequence.

Table 2-1. S1 Function Codes

Function	B0	B1	B2
ACV	1	1	1
DCV	0	1	1
300 mV	0	0	0
Ohms	0	0	1
	1	0	0
ACA	1	1	0
DCA	0	1	0

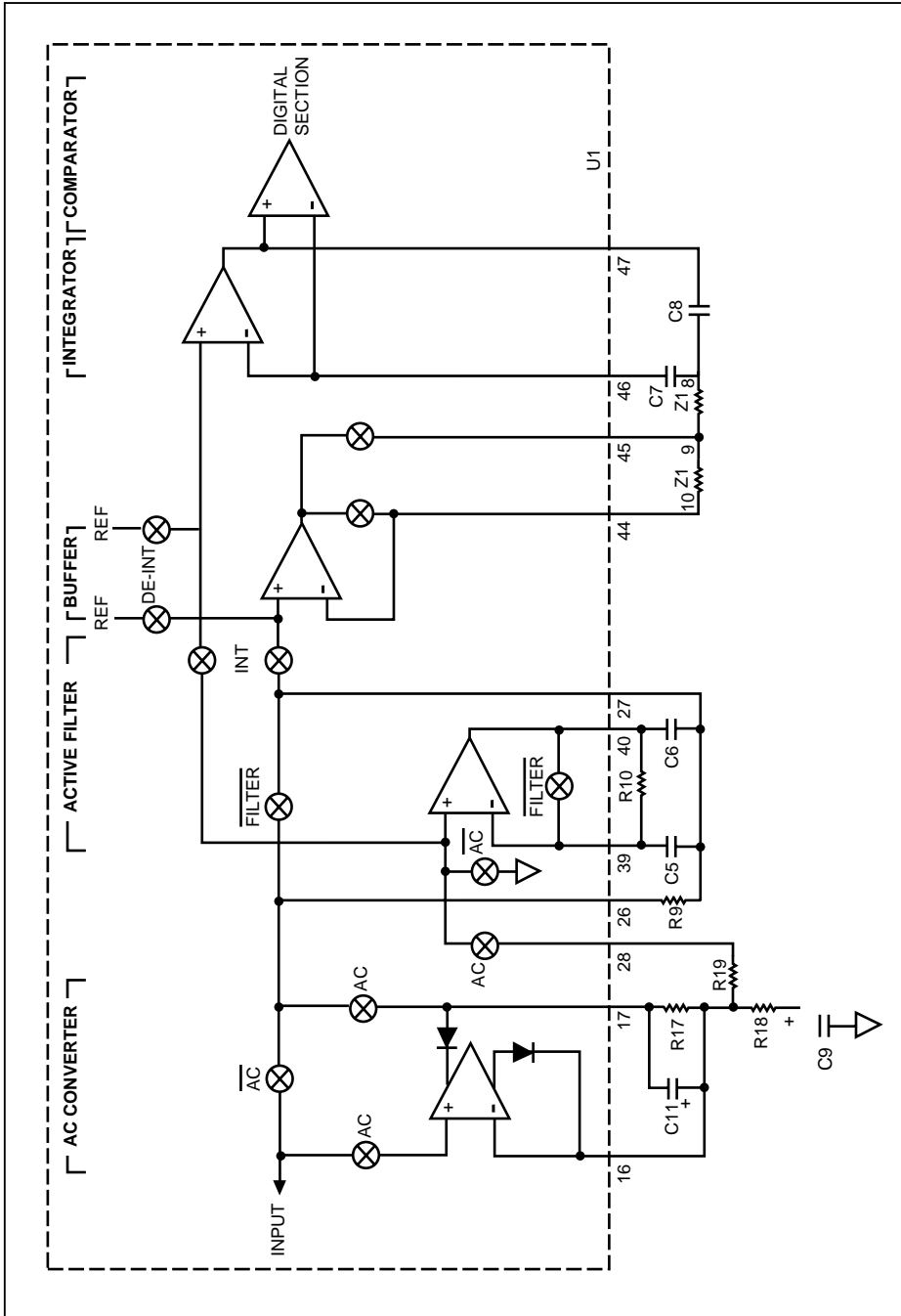

Figure 2-2. AC and A/D Converter

aaa03f.eps

Chapter 3

Maintenance

	Contents	Page
3-1.	Introduction.....	3-3
3-2.	PCA Access and General Maintenance	3-3
3-3.	Display Access.....	3-4
3-4.	Cleaning	3-4
3-5.	Performance Test	3-7
3-6.	Initial Procedure	3-7
3-7.	DC Voltage Test.....	3-7
3-8.	AC Voltage Test	3-8
3-9.	Resistance Test	3-8
3-10.	Diode Test	3-9
3-11.	DC mA Test.....	3-10
3-12.	DC Amps Test	3-11
3-13.	Calibration	3-11
3-14.	Troubleshooting.....	3-11
3-15.	Supplemental Troubleshooting Procedures.....	3-13
3-16.	Checking the Crystal Oscillator	3-13
3-17.	Checking The Reference Voltage	3-13
3-18.	Checking Display Drive Voltage	3-13
3-19.	Checking Beeper Drive Signal.....	3-13
3-20.	Tracing the VDC Signal Path.....	3-13

 **Warning**

These service instructions are for use by qualified personnel only. To avoid electric shock, do not perform any servicing other than that contained in the operator's manual unless you are qualified to do so.

3-1. Introduction

This chapter contains maintenance information for the performance testing, calibration, general maintenance, and troubleshooting of the 77 Series III Multimeter. For operator maintenance, refer to the Instruction Sheet.

The performance tests are recommended as a preventive maintenance tool to verify proper instrument operation. A one year calibration cycle is recommended to maintain the specifications given in the Users Manual. Test equipment required for the performance tests and calibration is listed in Table 3-1. If the recommended equipment is not available, instruments with equivalent specifications may be used.

Table 3-1. Recommended Test Equipment

Instrument Type	Recommended Model
Multi-Product Calibrator	Fluke 5500A

3-2. PCA Access and General Maintenance

 **Warning**

To avoid electrical shock, remove the test leads before opening the case, and close the case before operating the meter. To prevent fire, install fuses with the rating shown on the back of the meter.

Caution

To avoid contaminating the pca with oil from the fingers, handle it by the edges or wear gloves. PCA contamination may not cause immediate instrument failure in controlled environments. Failures typically show up when contaminated units are operated in humid areas.

Use the following procedure for removing the pca (printed circuit assembly) from its case:

1. Set the function switch to OFF, and disconnect test leads if they are installed.
2. Remove the four Phillips screws from the bottom cover.
3. Turn the meter face up, grasp the top cover, and pull the top cover from the meter.
4. Remove the 11A fuse to access the screw that holds the pca to the case bottom.
5. The pca may now be removed from the bottom cover.

3-3. Display Access

Caution

Do not handle the conductive edges of the LCD interconnects. If contaminated, clean with alcohol.

Refer to Figure 3-1.

1. Remove the four Phillips screws from the back side of the pca.
2. Remove the LCD mounting bracket.
3. Insert a small screwdriver under the edges of the display holding bracket, and gently pry the bracket loose from the snaps.
4. Turn the bracket upside down to remove the LCD.
5. Before installing a new LCD, make sure that all connector contact points are clean.

3-4. Cleaning

Caution

To avoid damaging the meter, do not use aromatic hydrocarbons or chlorinated solvents for cleaning. These solutions will react with the plastics used in instruments.

Do not allow the LCD to get wet. Remove the display assembly before washing the pca and do not install until the pca is completely dry.

Do not use detergent of any kind for cleaning the pca.

Do not remove lubricants from the switch when cleaning the pca.

Clean the instrument case with a mild detergent and water.

The pca may be washed with isopropyl alcohol or deionized water and a soft brush. Remove the display assembly and fuses before washing, and avoid washing the switch if possible. Dry the pca with clean dry air at low pressure, then bake it at 50°C for 24 hours.

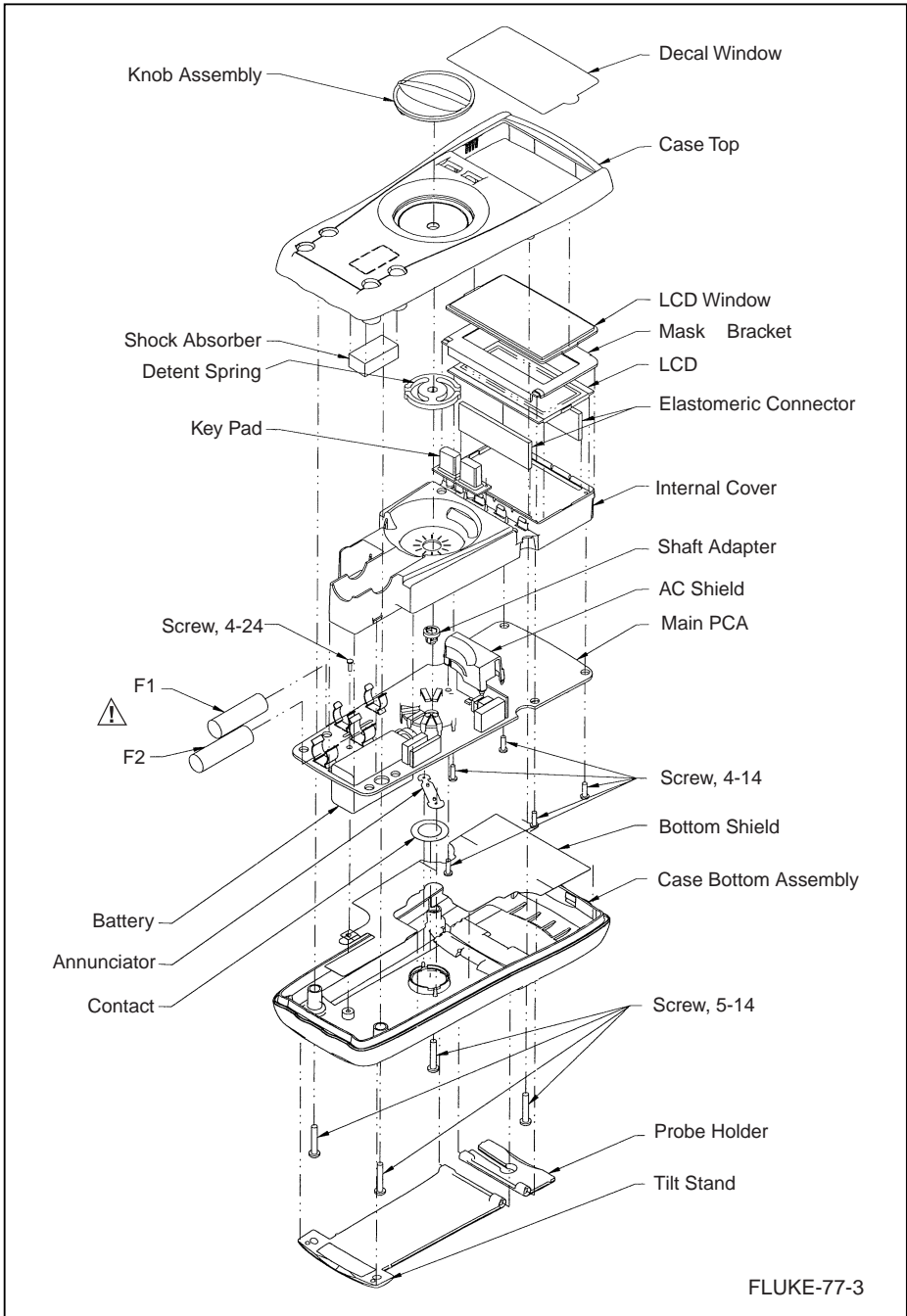

FLUKE-77-3

aaa12c.eps

Figure 3-1. Assembly Details

3-5. Performance Test

Performance tests are recommended for incoming inspection, periodic maintenance, and for verifying the specifications in the Instruction Sheet. If the instrument fails any part of the test, calibration and/or repair is indicated.

In the performance tests, the Fluke 77 Series III is referred to as the unit under test (UUT).

3-6. Initial Procedure

1. Allow the UUT to stabilize to room temperature $23^{\circ}\text{C} \pm 5^{\circ}\text{C}$ ($73^{\circ}\text{F} \pm 9^{\circ}\text{F}$).
2. Check the fuses and battery, and replace them if necessary.

 **Warning**

To prevent fire, install fuses in accordance with the rating shown on the back of the meter.

 **Warning**

To avoid false readings, which could lead to possible electric shock or personal injury, replace the battery as soon as the battery indicator () appears.

3-7. DC Voltage Test

 **Warning**

Connect the ground/common/low side of the DC calibrator to COM on the UUT.

1. Set the UUT function switch to VDC, and connect the DC Voltage Calibrator output to the $\text{V}\Omega \rightarrow \text{—}$ and COM input terminals of the UUT.
2. Referring to Table 3-2, set the DC Voltage Calibrator for the output indicated in steps 1 through 4 only. Verify that the UUT display reading is within the limits shown.
3. Set the DC Voltage Calibrator for an output of +300 mV, and switch the UUT to the 300 mV function. Verify that the UUT display reading is within the limits shown in Table 3-2 (step 5).

Table 3-2. DC Voltage Test

Step	DC Input Voltage	Display Reading
		1
2	+27V	26.91 to 27.09V DC
3	+270V	269.1 to 270.9V DC
4	+1000V	995 to 1005V DC
5*	+300 mV	299.0 to 301.0V DC

*300 mV function only

3-8. AC Voltage Test



Warning

Connect the ground/common/low side of the AC calibrator to COM on the UUT.

1. Set the UUT function switch to VAC, and connect the AC Voltage Calibrator to the **VΩ→** and COM input terminals.
2. Set the AC Voltage Calibrator for the output given in Table 3-3, verify that the UUT display reading is within the limits shown.

Note

When the input is open in the VAC function, it is normal for the meter to read some counts on the display. This is due to ac pickup in the ac amplifier when the ac amplifier when the ac amplifier is unterminated.

Table 3-3. AC Voltage Test

Step	Input		Display Reading
	Voltage	Frequency	
1	2.7V	100 Hz	2.644 to 2.756V AC
2	2.7V	500 Hz	2.644 to 2.756V AC
3	1000V	100 Hz	978 to 1022V AC
4	1000V	1000 Hz	978 to 1022V AC

3-9. Resistance Test

1. Select the ohms function on the UUT.
2. Connect the Ohms Calibrator or Decade Resistor to the **VΩ→** and COM input terminals of the UUT.

Referring to Table 3-4, set the Ohms Calibrator or Decade Resistor to the resistance value indicated in steps 1 through 6. Verify that the display reading is within the limits shown.

3-10. Diode Test

1. Set the UUT to the Diode Test function.

Note

On Fluke 5100 series calibrators, activate the 50 Ω divider override. On Fluke 5500A calibrators, lock voltage to the 33V range.

2. Apply an input from the DC Voltage Calibrator of +.090V dc to the **V Ω →** and COM input terminals of the UUT, and verify that the beeper is on.
3. Increase the DC Voltage Calibrator output to +.110V dc, and verify that the beeper is off.

Table 3-4. Resistance Test

Step	Input Resistance	Display Reading
1	short	0.0 to 0.3Ω
Decades of 1:		
2	100Ω	99.2 to 100.8Ω (plus 0 reading)
3	1kΩ	994 to 1006 Ω
4	10 kΩ	9.94 to 10.06 kΩ
5	100 kΩ	99.4 to 100.6 kΩ
6	1 MΩ	.994 to 1.006 MΩ
7	10 MΩ	9.79 to 10.21 MΩ
Decades of 1.9:		
2	190Ω	188.7 to 191.3Ω (plus 0 reading)
3	1.9 kΩ	1889 to 1911 Ω
4	19 kΩ	18.89 to 19.11 kΩ
5	190 kΩ	188.9 to 191.1 kΩ
6	1.9 MΩ	1.889 to 1.9111 MΩ
7	19 MΩ	18.61 to 19.39 MΩ
Decades of 2.7:		
2	270Ω	268.3 to 271.7Ω (plus 0 reading)
3	2.7 kΩ	2685 to 2715Ω
4	27 kΩ	26.85 to 27.15 kΩ
5	270 kΩ	268.5 to 271.5 kΩ
6	2.7 MΩ	2.685 to 2.715 MΩ
7	27 MΩ	26.45 to 27.55 MΩ

3-11. DC mA Test

1. Set the output of the DC Current Calibrator to zero, and connect it to the 300mA and COM input terminals of the UUT.
2. Set the DC Current Calibrator to the output shown in Table 3-5, and verify that the UUT display reading is within the limits shown.

Table 3-5. DC mA Test

Step	Input Current	Display Reading
1	+27 mA	26.57 to 27.43 DC
2	+200 mA	196.8 TO 203.2 DC

3-12. DC Amps Test

1. Set the DC Current Calibrator to standby and connect it to the 10A and COM input terminals of the UUT.
2. Apply currents as indicated in Table 3-6, and verify that the display reading is within the limits shown.

Table 3-6. DC Amps Test

Step	Input Current	Display Reading
1	+10A	9.83 to 10.17 DC

3-13. Calibration

1. Set the DC Voltage Calibrator to zero, and set the UUT to the VDC function.
2. Remove the case top cover as previously described.
3. Connect the DC Voltage Calibrator to the $V\Omega \rightarrow$ and COM input terminals of the UUT.
4. Set the DC Voltage Calibrator for an output of +3.000V dc, and adjust R8 for a display reading of +3.000V dc \pm .001V.

3-14. Troubleshooting

A troubleshooting tree for the meter is given in Figure 3-2. Faults are listed in the order of probability. This tree gives a systematic approach to isolation of problems to a component or component area. Complete the procedures in the order listed in this table; all measurements are made with respect to common.

Also, supplemental troubleshooting procedures are presented in the following paragraphs.

When troubleshooting the meter, use the precautions listed on the static awareness sheet to prevent damage from static discharge.

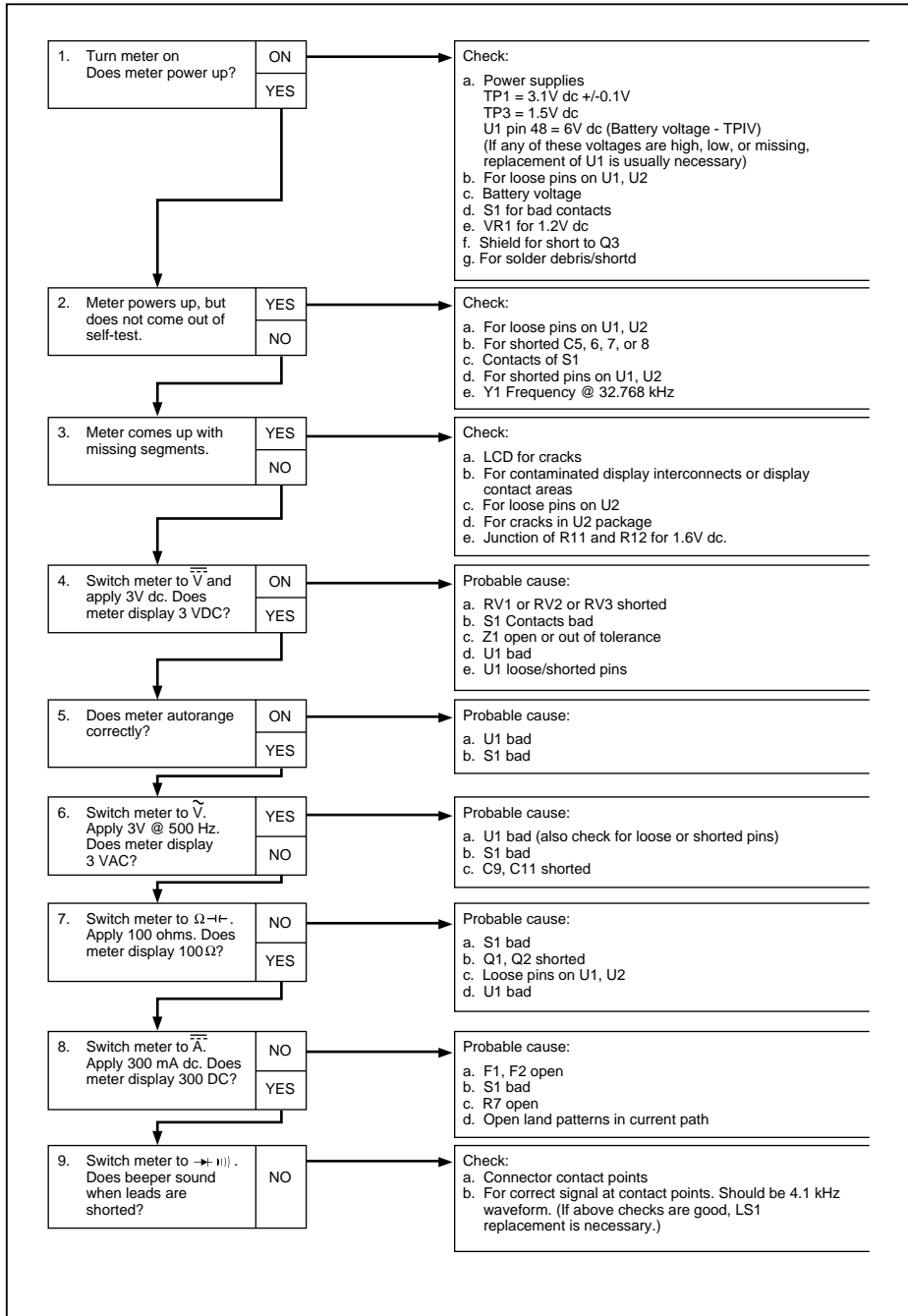

Figure 3-2. Troubleshooting Tree

aaa02f.eps

3-15. Supplemental Troubleshooting Procedures

3-16. Checking the Crystal Oscillator

Connect an oscilloscope or counter to pin 54 U1 or to the junction of C12 and the Y1 crystal. Check for a 32.768-kHz sine wave approximately 600 mV p-p in amplitude. Note that U2 and the display will not work if the clock circuit is not working.

Probable related failures include: U1, Y1, or C12.

3-17. Checking The Reference Voltage

Check for a reference voltage of 1.00V dc (adjustable by R8) at pin 14 of U1 or at the junction of R15 and R16.

Probable related failures include: R8, R14, R15, R16, VR1, or CR2.

3-18. Checking Display Drive Voltage

Check that VM (V middle) is 1.6V dc \pm .1V at pin 28 U2 or at the junction of R11 and R12.

Probable related failures include: R11 or R12.

3-19. Checking Beeper Drive Signal

Put the unit in the Diode Test Mode and short the input leads. Using an oscilloscope, measure the signal at pin 3 of U1. The signal should be a 4V p-p symmetrical square wave at about 4.1 kHz.

A probable related failure is: U1

3-20. Tracing the VDC Signal Path

Use the following procedure to trace the VDC signal path:

1. Set the UUT to the VDC function and apply 2V dc to the input.
2. Using a DVM, measure the input at J1 for 2V dc.
3. Measure pin 1 of Z1 input divider for 2V dc. Probable related failures include: R1, S1, RV1, or RV2.

Note

Measurements in steps 4,5, and 6 may be affected by loading.

4. Measure Z1 pin 3 for 200 mV dc. Probable related failures are: Z1, U1.
5. Measure for 200 mV dc at the active filter input (AFI, pin 26 of U1 or R9). A probable failures is: U1
6. Measure for 200 mV at the active filter output (AFO, pin 27 of U1 or R9). Probable related failures are: R9, C5, or C6.



static awareness



A Message From
Fluke Corporation

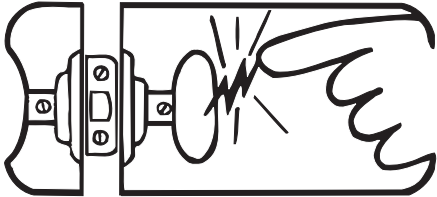

Some semiconductors and custom IC's can be damaged by electrostatic discharge during handling. This notice explains how you can minimize the chances of destroying such devices by:

1. Knowing that there is a problem.
2. Learning the guidelines for handling them.
3. Using the procedures, packaging, and bench techniques that are recommended.

The following practices should be followed to minimize damage to S.S. (static sensitive) devices.

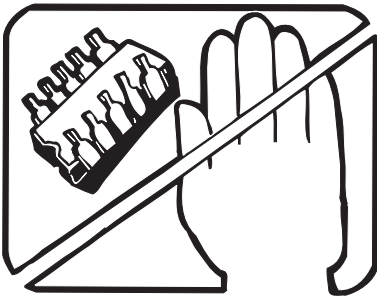

1. MINIMIZE HANDLING

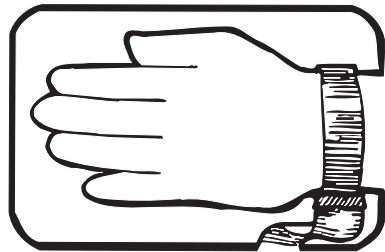

3. DISCHARGE PERSONAL STATIC BEFORE HANDLING DEVICES. USE A HIGH RESISTANCE GROUNDING WRIST STRAP.

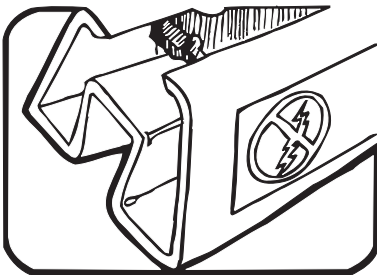

2. KEEP PARTS IN ORIGINAL CONTAINERS UNTIL READY FOR USE.

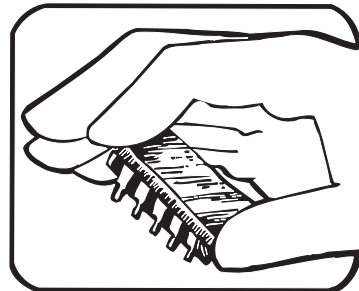

4. HANDLE S.S. DEVICES BY THE BODY.

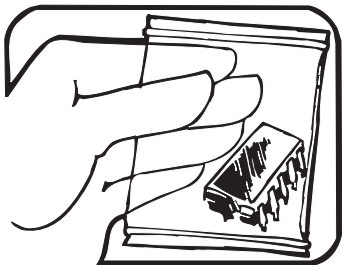

5. USE STATIC SHIELDING CONTAINERS FOR HANDLING AND TRANSPORT.

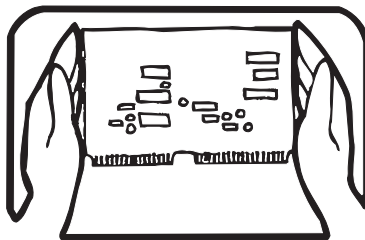

8. WHEN REMOVING PLUG-IN ASSEMBLIES HANDLE ONLY BY NON-CONDUCTIVE EDGES AND NEVER TOUCH OPEN EDGE CONNECTOR EXCEPT AT STATIC-FREE WORK STATION. PLACING SHORTING STRIPS ON EDGE CONNECTOR HELPS PROTECT INSTALLED S.S. DEVICES.



6. DO NOT SLIDE S.S. DEVICES OVER ANY SURFACE.

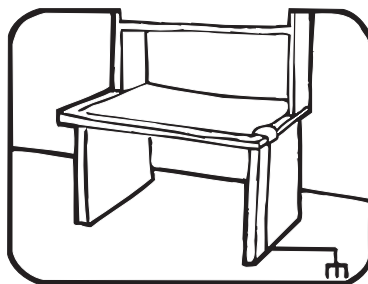

9. HANDLE S.S. DEVICES ONLY AT A STATIC-FREE WORK STATION.

10. ONLY ANTI-STATIC TYPE SOLDER-SUCKERS SHOULD BE USED.

11. ONLY GROUNDED-TIP SOLDERING IRONS SHOULD BE USED.

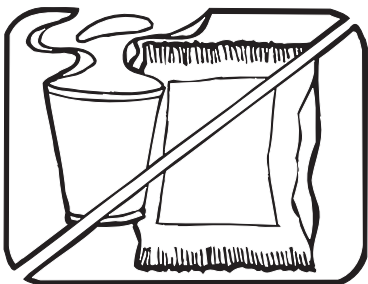

7. AVOID PLASTIC, VINYL AND STYROFOAM® IN WORK AREA.

PORTIONS REPRINTED
WITH PERMISSION FROM TEKTRONIX INC.
AND GERNER DYNAMICS, POMONA DIV.

© Dow Chemical

Chapter 4

List of Replaceable Parts

	Contents	Page
4-1.	Introduction.....	4-3
4-2.	How to Obtain Parts.....	4-3
4-3.	Newer Instruments	4-3
4-4.	Service Centers	4-3
4-5.	Manual Status Information	4-4
4-6.	Parts Lists.....	4-4

4-1. Introduction

This section contains an illustrated list of replaceable parts for 77 Series III Multimeter.

4-2. How to Obtain Parts

Electrical components may be ordered directly from the Fluke Corporation and its authorized representatives by using the part number under the heading FLUKE PN. In the U.S., order directly from the Fluke Parts Dept. by calling 1-800-526-4731. Parts price information is available from the Fluke Corporation or its representatives. Prices are also available in a Fluke Replacement Parts Catalog which is available on request.

In the event that the part ordered has been replaced by a new or improved part, the replacement will be accompanied by an explanatory note and installation instructions, if necessary.

To ensure prompt delivery of the correct part, include the following information when you place an order:

- Part number and revision level of the pca containing the part.
- Reference designator
- Fluke stock number
- Description (as given under the DESCRIPTION heading)
- Quantity
- Instrument Model, Serial Number, and Firmware Numbers

4-3. Newer Instruments

Changes and improvements made to the instrument are identified by incrementing the revision letter marked on the affected pca. These changes are documented on a manual supplement which, when applicable, is included with the manual.

4-4. Service Centers

To locate an authorized service center, call Fluke using any of the phone numbers listed below, or visit us on the World Wide Web: www.fluke.com

USA: 1-888-99-FLUKE (1-888-993-5853)

Canada: 1-800-36-FLUKE (1-800-363-5853)

Europe: +31 402-678-200

Japan: +81-3-3434-0181

Singapore: +65-738-5655

Anywhere in the world: +1-425-446-5500

4-5. Manual Status Information

The following Manual Status Information table defines the assembly revision levels that are documented in the manual. Revision levels are printed on the component side of each pca.

Manual Status Information

Assembly	Revision Level
A1 Main PCA	c

4-6. Parts Lists

The following tables list the replaceable parts for the 77 Series III Multimeter. Parts are listed by assembly; alphabetized by reference designator. Each assembly is accompanied by an illustration showing the location of each part and its reference designator. The parts lists give the following information:

- Reference designator
- An indication if the part is subject to damage by static discharge
- Description
- Fluke stock number
- Total quantity
- Any special notes (i.e., factory-selected part)

Caution

A * symbol indicates a device that may be damaged by static discharge.



Note

This instrument may contain a Nickel-Cadmium battery. Do not mix with the solid waste stream. Spent batteries should be disposed of by a qualified recycler or hazardous materials handler. Contact your authorized Fluke service center for recycling information.

Warning

This instrument contains a fusible resistor (pn 740662). To ensure safety, use exact replacement only.

Table 4-1. Final Assembly

Ref Des	Description	Fluke PN	Qty	Notes
A1	MAIN PCA	NA	1	
BT1	BATTERY,9V,0-15MA	696534	1	
DS1	LCD,3.75 DIGIT,BAR GRAPH,MULTIPLIED	602927	1	
F1△	FUSE,.406x1.375,0.440A,1000V,FAST	943121	1	
F2△	FUSE,.406X1.5, 11A, 1000V, FAST	803293	1	
H1	SCREW,PH,P,THD FORM,STL,4-24,.250	519116	1	
H2	SCREW,PH,P,AM THD FORM,STL,4-14,375	448456	5	
H7	SCREW,PH,P,AM THD FORM,STL,5-14,.759	832246	4	
LS1	AF TRANSD,PIEZO,20MM,600MW,6KHZ	642991	1	
MP4	HOLDER,PROBE	648748	1	
MP5	STAND,TILT	648961	1	
MP6	LABEL,WINDOW	844337	1	
MP9	SHIELD,AC	648755	1	
MP10	SPRING,DETENT	822643	4	
MP11	KNOB,SWITCH	648706	1	
MP12	ADAPTER,SHAFT	649175		
MP14	CASE BOTTOM ASSEMBLY	659786	1	
MP16	SHOCK ABSORBER	428441	1	
MP17	CASE TOP PAD XFR	648763	1	
MP18	WINDOW, LCD	648714	1	
MP19	COVER,INTERNAL	648722	1	
MP20	MASK,BRACKET,77-3 WITH LOGO	648771	1	
MP21	CONN,ELASTOMERIC,LCD TO PWB,1.900 L	650264	2	
MP23	SHIELD,BOTTOM	648839	1	
MP32	TEST LEADS	TL75	1	
MP40	CONTACT,ANNUNCIATOR	642983	1	
S2	KEYPAD	648847	1	
TM1	77/75/23/21 SERIES III INSTRUCTION SHEET	686571	1	
TM2	77 SERIES III SERVICE MANUAL	800604	1	

△ To ensure safety, use exact replacement only.

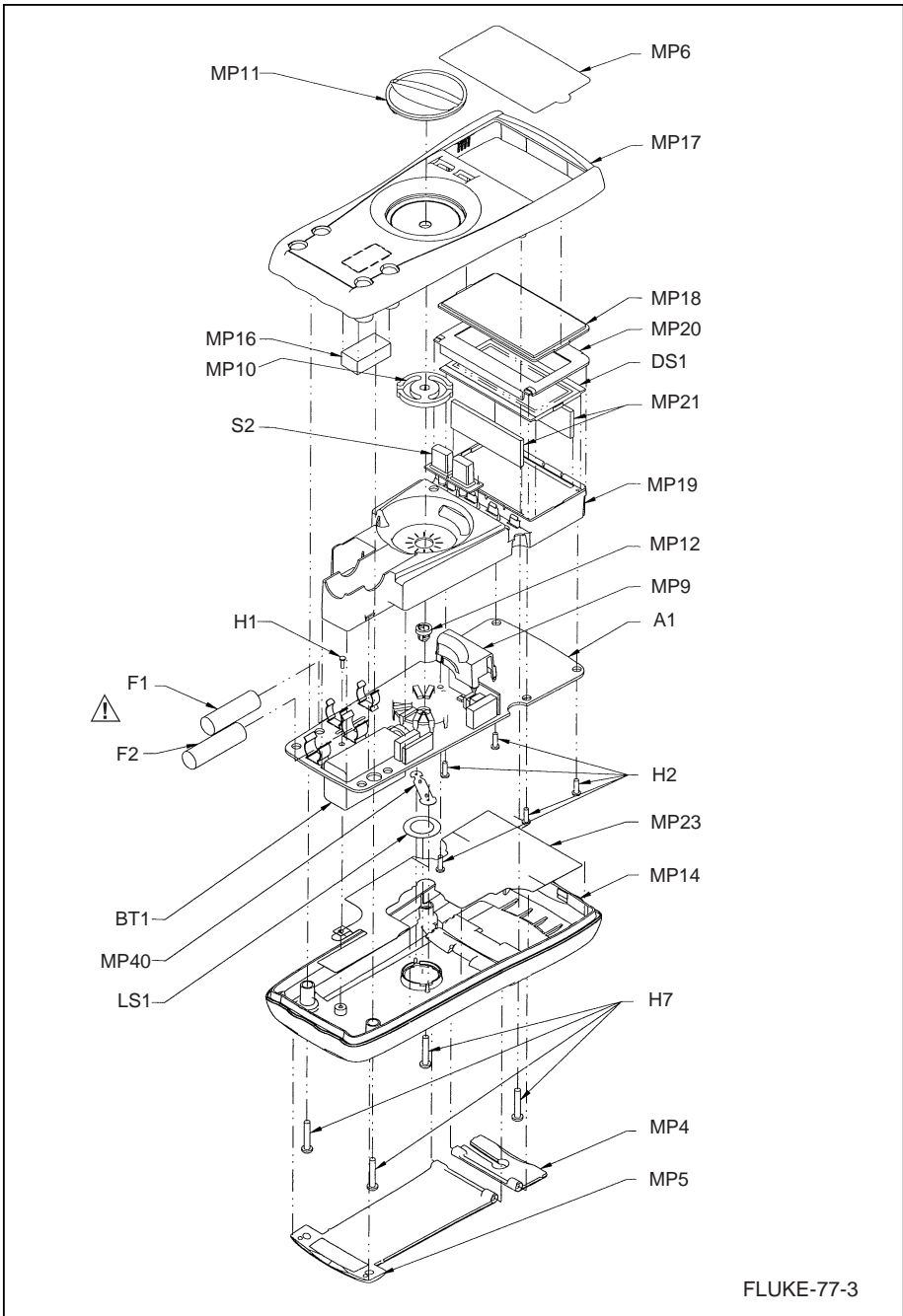

FLUKE-77-3

aaa05c.eps

Figure 4-1. Final Assembly

Table 4-2. A1 Main PCA

Ref Des	Description	PN	Qty.	Notes
C1	CAP,POLYES,0.0UF, ±10%,1000V	822361	1	
C2,C3	CAP,CER,0.1UF, ±10%,25v,X7R	942529	2	
C4	CAP,TA,2.2UF, ±20%,20V	854760	1	
C5,C6	CAP,POLYCA,0.027UF, ±10%,63V	720979	2	
C7	CAP,TA,0.47UF, ±20%,25V	876180	1	
C8	CAP,POLYPR,0.033UF, ±10%,63V	721050	1	
C9	CAP,TA,10UF, ±20%,10V,3528	603032	1	
C10	CAP,CER,0.1UF, ±10%,25V,XR7	942529	1	
C11	CAP,TA,2.2UF, ±20%,6V,3216	930248	1	
C12	CAP,CER,47PF, ±5%,50V,C0G	494633	1	
C13	CAP,CER,0.22UF,+80%,-20%,50V,Y5V	740597	1	
C14,C15	CAP,CER,33PF, ±5%,50V,C0G	603172	1	
C16	CAP,CER,47PF, ±5%,50V,COG	494633	1	
CR1,CR2	* DIODE,SI,75V,250MA,SOT-23	830489	2	
J1-4	RECEPTACLE,INPUT	658580	4	
Q1,Q3	* XSTR,SI,NPN,25V,.3W,SEL,SOT-23	821637	2	
Q2	* XSTR,SI,NPN,60V,350MW,SOT-23	742676	1	
R1	RES,WW,3.5K, ±5%,5W,20PPM	107695	1	
R2	RES,CERM,1K, ±5%,1W,200PPM	601176	1	
R3	RES,CERM,1M, ±5%,1W	655175	1	
R4	RES,CF,100K, ±1%,0.25W,100PPM	769802	1	
R5	RES,MF,402K, ±0.25%,0.25W,50PPM	602664	1	
R6	RES,WW,4.99, ±1%,5W	642923	1	
R7	RES,WW,.005, ±1%,.5W	740415	1	
R8	RES,VAR,CERM,100K, ±25%	912493	1	
R9,R19	RES,CERM,1M, ±1%,0.125W,100PPM	836387	2	
R10	RES,CERM,1.5M, ±1%,.1W,400PPM,	602703	1	
R11,12	RES,MF,10K, ±1%,0.1W,100PPM	928791	2	
R13	RES,MF,44.8K, ±0.25%,0.1W,50PPM	602679	1	
R14	RES,CF,61.9K, ±1%,0.125W,100PPM	821330	1	
R15	RES,MF,56.2K, ±1%,0.1W,100PPM	602687	1	
R16	RES,MF,205K, ±1%,0.1W,100PPM	602935	1	
R17	RES,CERM,20.5K, ±0.5%,100PPM	107711	1	
R18	RES,CERM,9.2K, ±0.5%,100PPM	107745	1	
RT1	THERMISTOR,POS,1.1K, ±±20%,25 C	602995	1	
RV1-,RV3	VARISTOR,910, ±±10%,1.0MA	876193	3	
S1	SWITCH,ROTARY	642918	1	
U1	* IC CHIP	791269	1	
U2	* IC, CMOS SM5A	603669	1	
VR1	* IC, 1.23V,150 PPM T.C.,BANDGAP	634451	1	
XBT1	BATTERY CONNECTOR	825976	1	
XF1	CONTACT, FUSE	659524	2	

Table 4-2. A1 Main PCA (cont)

Ref Des	Description	PN	Qty.	Notes
XF2	CONTACT, FUSE	707190	2	
Y1	CRYSTAL,32.768KHZ, $\pm\pm$ -1%,3 X 8MM	643031	1	
Z1	* RNET,CERM,SIP,FLUKE 77 HI V DIV.	946202	1	
Z2	* RNET,CERM,SIP, HI V PROTECT	103454	1	

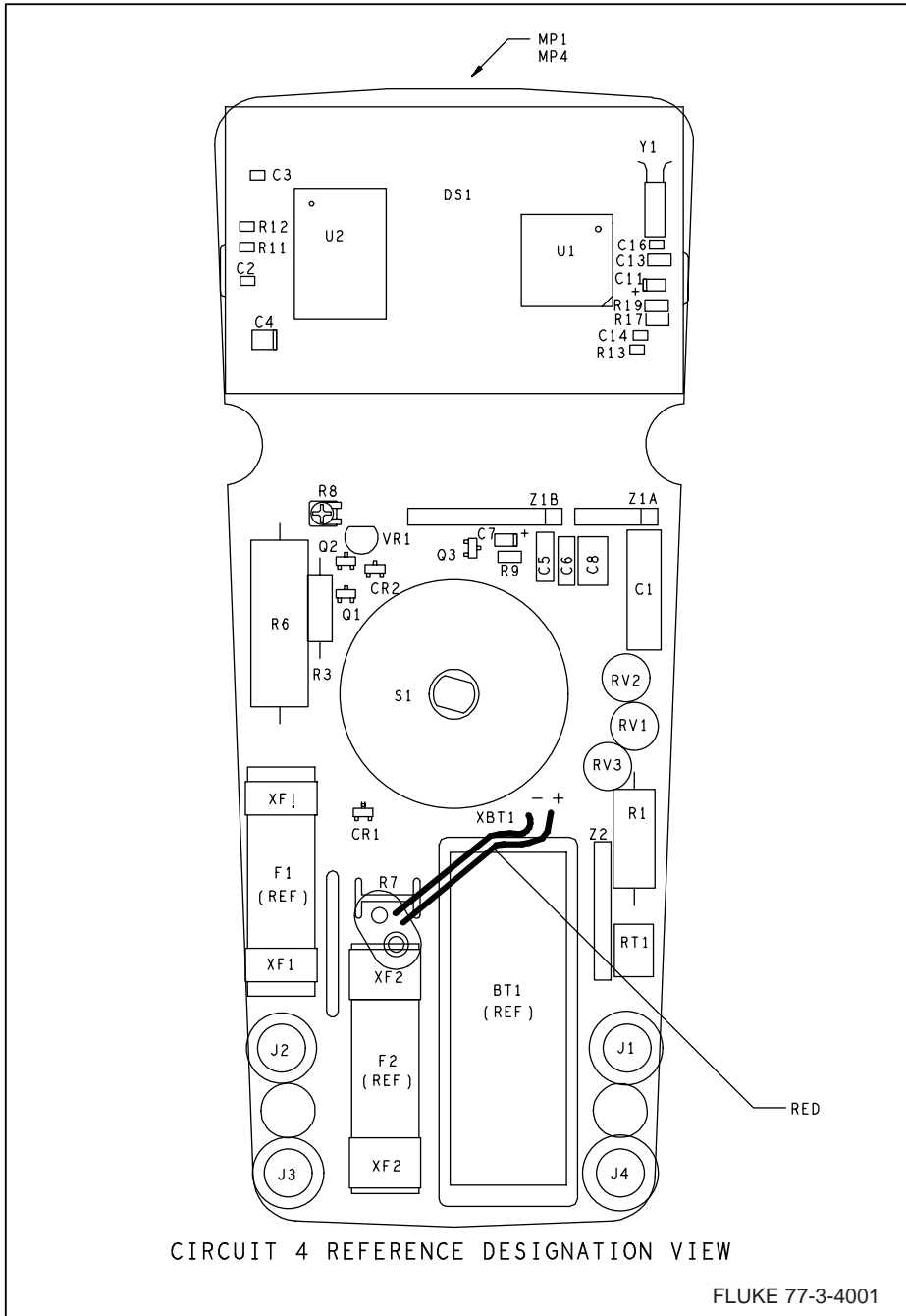

aaa06f.eps

Figure 4-2. A1 Main PCA

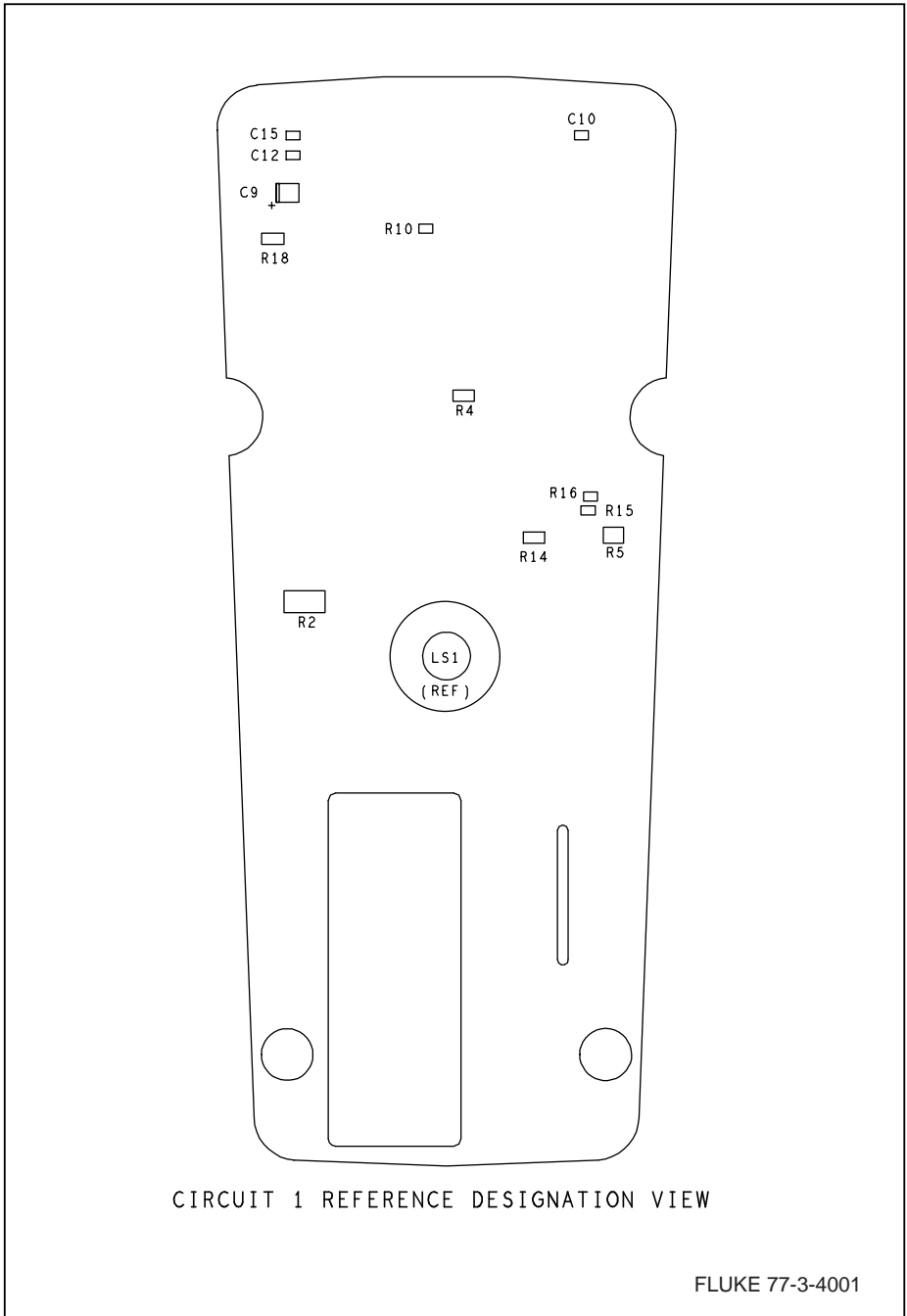

aaa07f.eps

Figure 4-2. A1 Main PCA (cont.)

Chapter 5

Schematic Diagrams

Table 5-1. Abbreviations

Abbreviation	Definition
ACA	AC Converter Feedback
ACHI	AC Converter High
ACL	All Clear, Reset
ACLO	AC Converter Low
AFI	Active Filter Input
AFO	Active Filter Output
AM0	Amp[s] Input
AM1	Amps Divide by 10
AZ	Auto Zero Point
BPR	Beeper Driver
BT	Battery
CLK	Clock Output
COM	Common
DCS	DC Sense
EC	Reference Voltage
FA0	Active Filter Amp Output
FA(-)	Active Filter Amp Feedback
INT	Integrator Ooutput
K0	Buffer x 1 Output
K1	Buffer Divide by 3 Output
LS	Loud Speaker
LO	Low
OHS	Ohms Sense
RNG	Range
RRS	Reference Resistor Sense
RT	Thermistor
VSS	Negative Supply Voltage
BDD	Positive Supply Voltage
VM	Volts Middle
WW	Wirewound
XTL	Crystal Oscillator Inputs
Z	Impedance

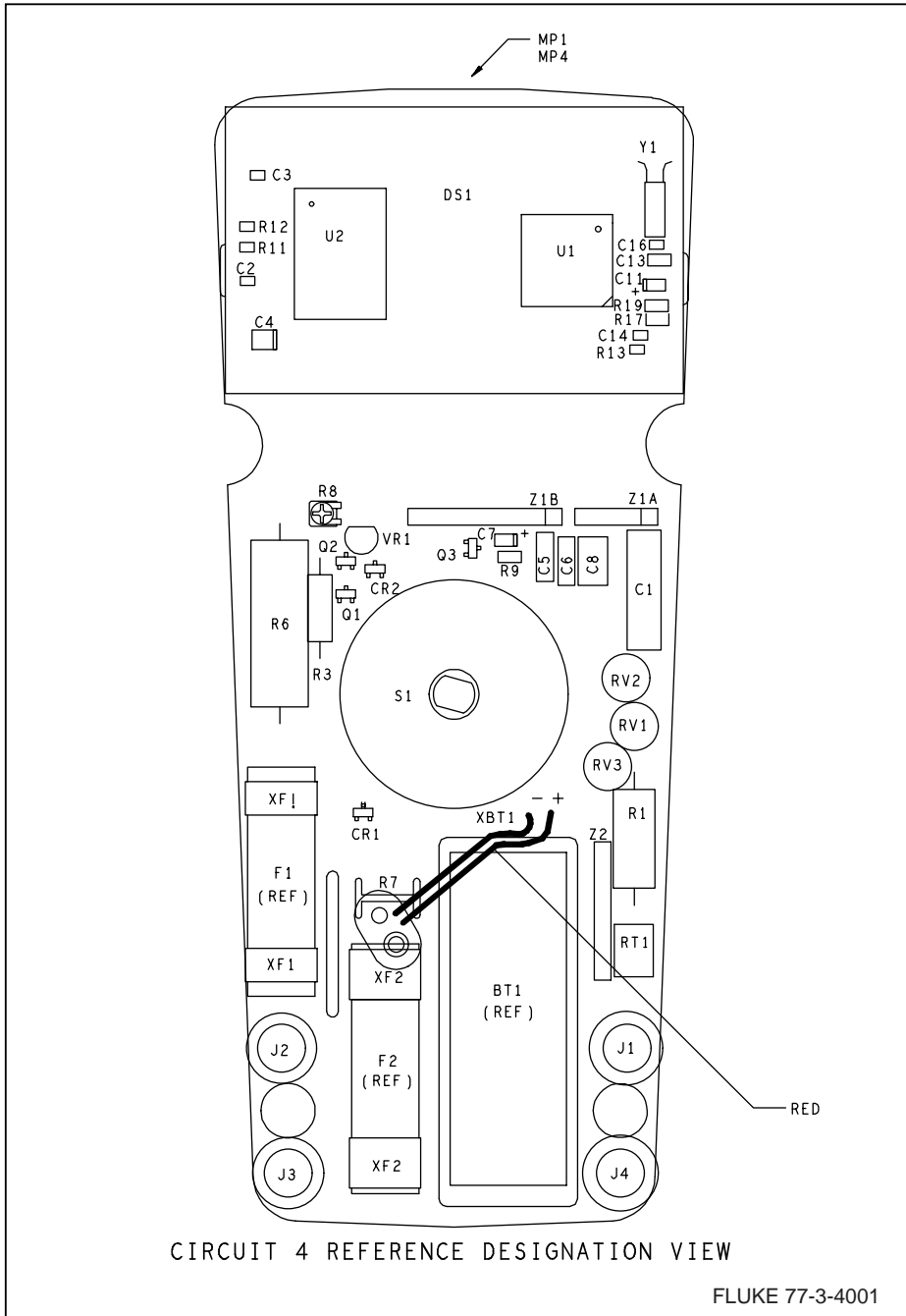
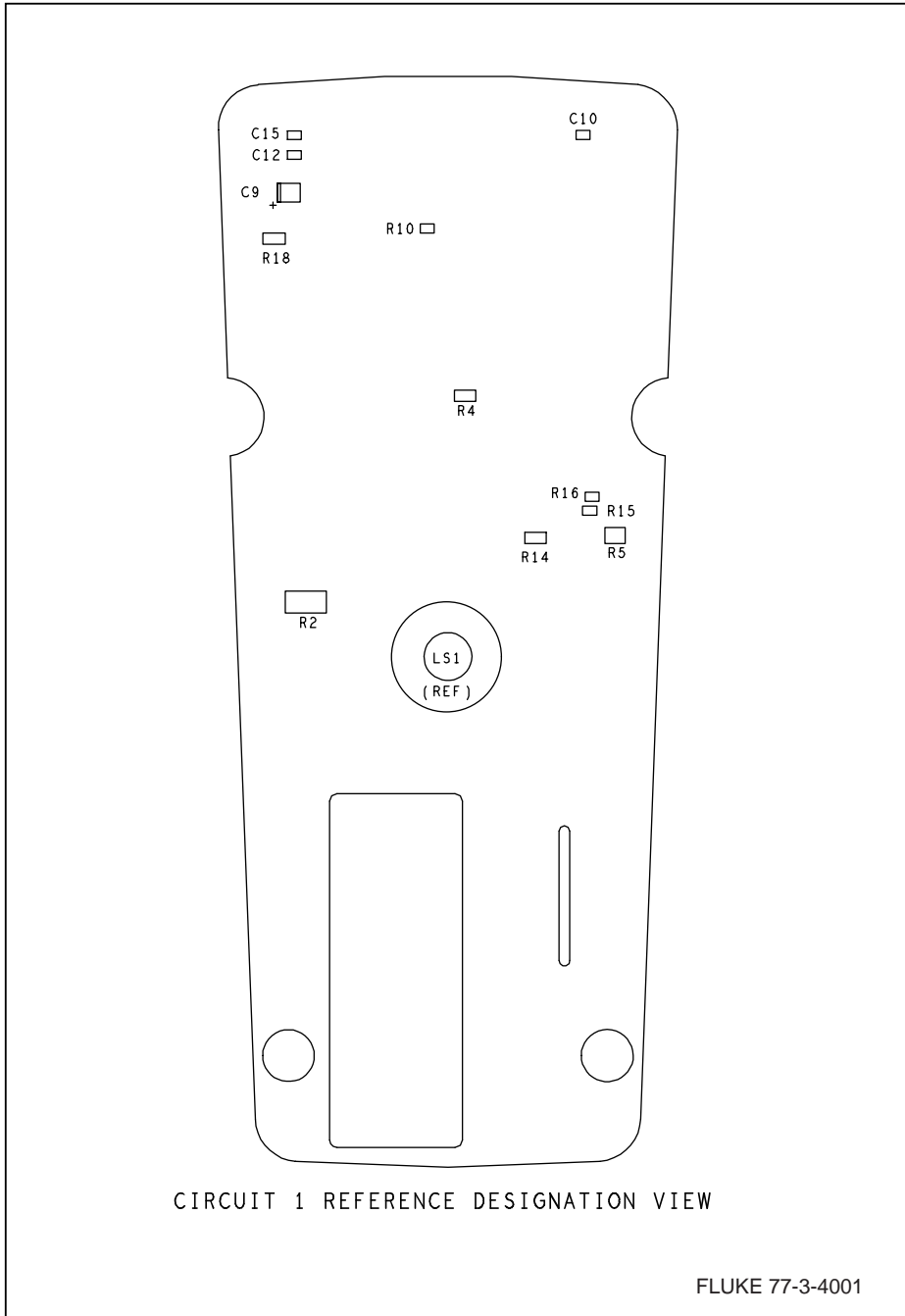

Figure 5-1. A1 Main PCA

aaa06f.eps



aaa07f.eps

Figure. A1 Main PCA (cont)

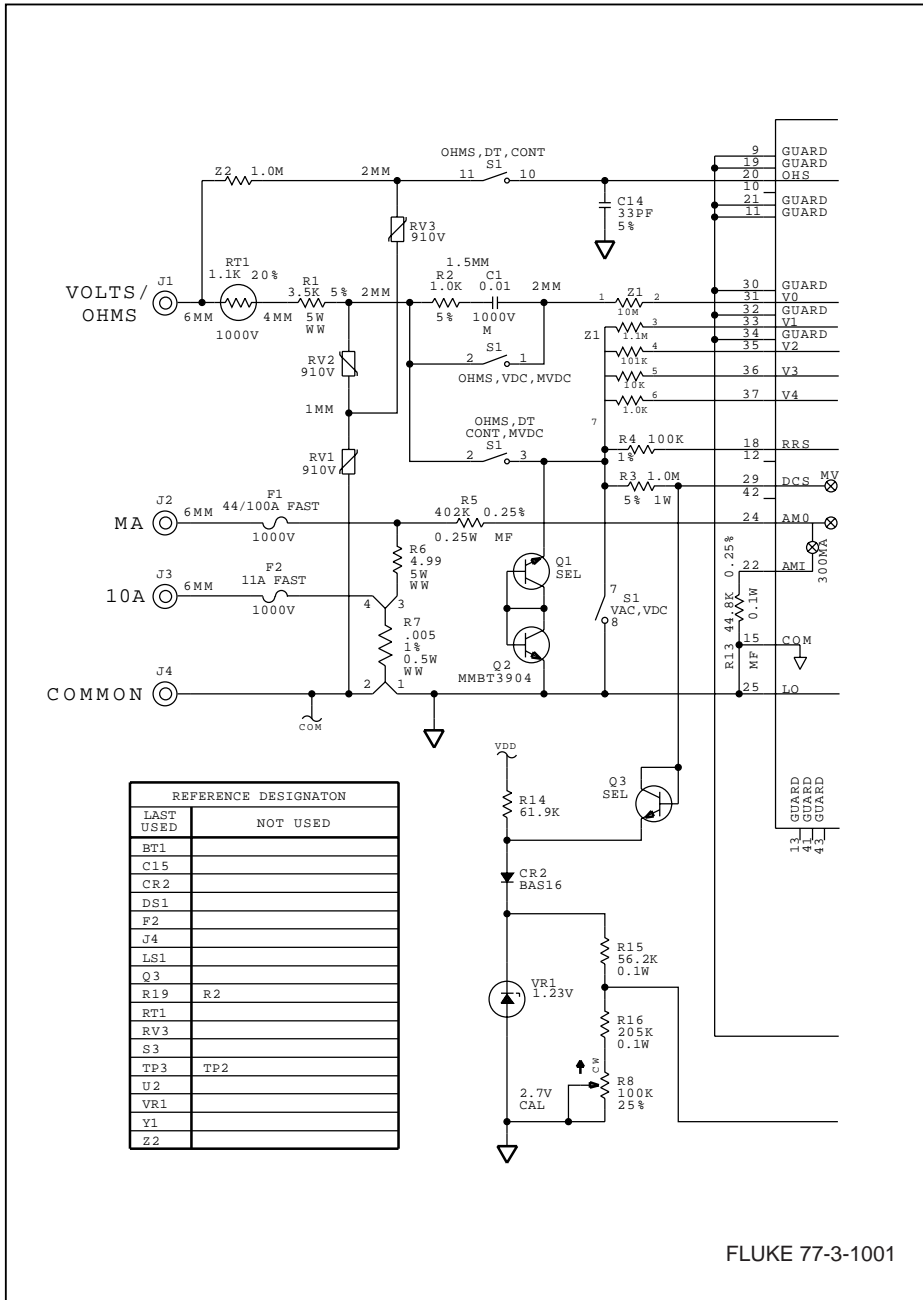
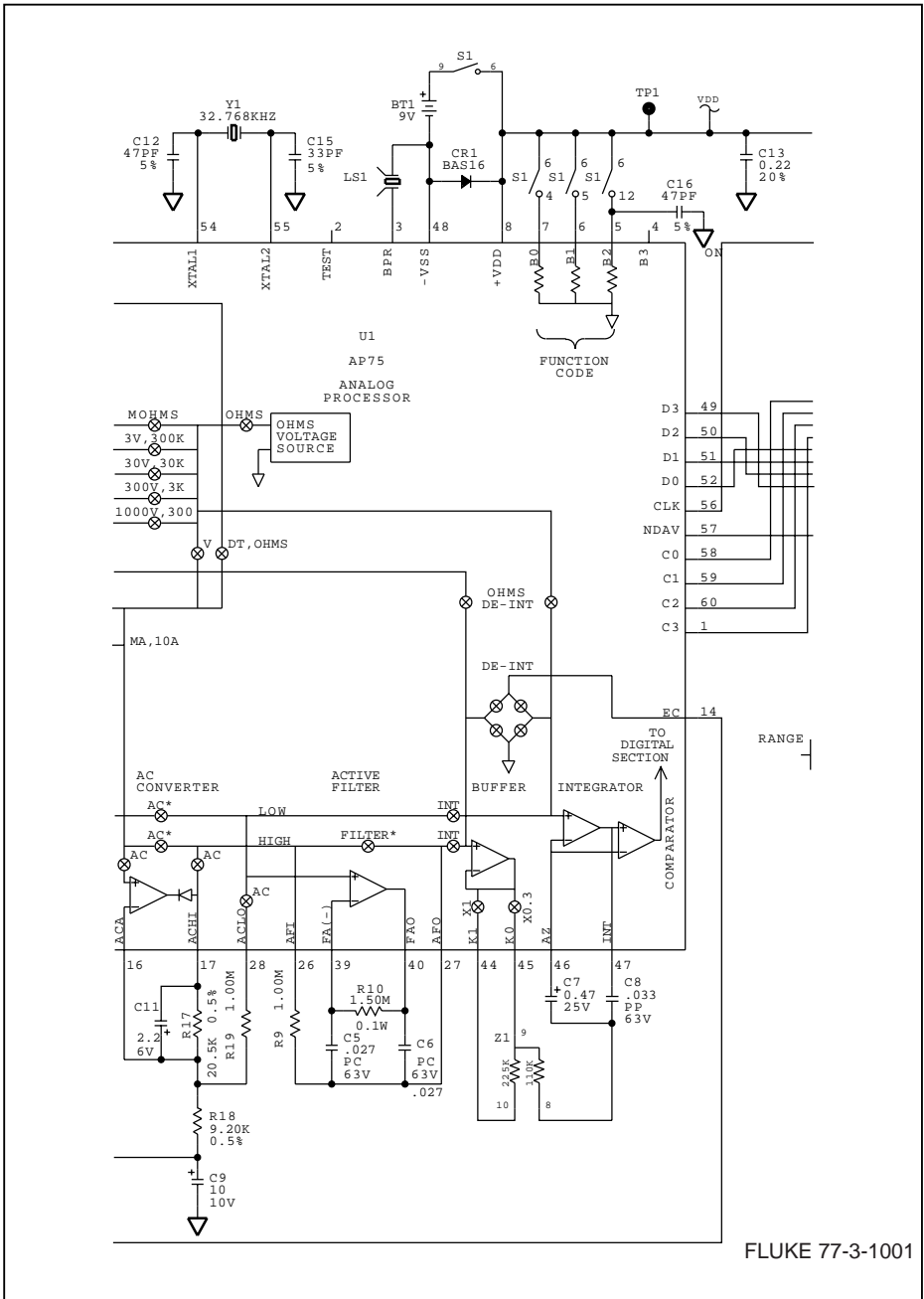

Figure 5-1. A1 Main PCA (cont)

aaa09f.eps



FLUKE 77-3-1001

Figure 5-1. A1 Main PCA (cont)

aaa10f.eps

