



DC Power Supply

# GP-1303DU/TP, GP-1305DU/TP GP-1503DU/TP

## Operation Manual



 EZ Digital Co.,Ltd.

---

---

## SAFETY SUMMARY

---

---

### SAFETY PRECAUTIONS

Please take a moment to review these safety precautions.  
They are provided for your protection and to prevent damage to the power supply.  
This safety information applies to all operator and service personnel.

NOTE : If the equipment is used in a manner not specified by the manufacturer, the protection provided by the equipment may be impaired.

### CAUTION AND WARNING STATEMENTS.

**CAUTION** : Is used to indicate correct operation or maintenance procedures in order to prevent damage to or destruction of the equipment or other property.

**WARNING** : Calls attention to a potential danger that requires correct procedures of practices in order to prevent personal injury.

#### SYMBOLS



Caution(Refer to accompanying documents)



PROTECTIVE CONDUCTOR TERMINAL

---

---

---

---

## INTRODUCTION

---

---

Thank you for purchasing an EZ DIGITAL product.

The instruments produced by EZ DIGITAL company are high technology products made under strict quality control.

We guarantee exceptional precision and utmost reliability.

For proper use of this product, please read this manual carefully.

---

---

1. To maintain the precision and the reliability of the product, use it in the standard settings.

Operating temperature : 5°C ~ +40°C

Operating humidity : 50% ~ 80%

Storage temperature : 0°C ~ +70°C

Storage humidity : less than 85%

2. For quality improvement, the exterior and specifications of the product can be changed without notice.

3. Should any further information be required, please contact our company's service center or sales outlet.



4. To carry the equipment, you should be used the both of handle.  
Don't carry to take the upper side of the vessel.

---

---

## WARRANTY

---

---

Warranty service covers one year from the date of original purchase.

In case of technical failure within a year, repair service will be provided by our service center or sales outlet free of charge.

We charge for repairs after the one-year warranty period expires.

When the failure is the result of user's neglect, natural disaster or accident, we charge for repairs regardless of the warranty period.

For more information on repair service, be sure to contact our service center or sales outlet.

---

---

---

---

# CONTENTS

1. INTRODUCTION	1
2. PRECAUTIONS	3
2-1. To Replace the Fuse	3
2-2. Installaion and Handling Precautions	5
2-3. Cleaning	6
3. SPECIFICATION	7
4. DESCRIPTION OF PANEL'S FUNCTION	9
4-1. Front Panel	9
4-2. Rear Panel	10
4-3. Front,Rear of Panel Functions	11

---

---

5. OPERATIONS	13
5-1. Pre-Operational Checking	13
5-2. Operational Procedure	13
5-2-1 Independent Operation	13
5-2-2 Parallel Operation	15
5-2-3 Serial Operation	17
6. 5V/3A OUTPUT	19
7. SURROUNDING ENVIROMENT OF USE	20

---

---

# 1.INSTRUCTIONS

GP-DU/TP Series are 2 channel(DU) or 3 channel(TP) DC Power Supply.  
They have low ripple,high stability and excellent electric features.

Without any connection in serial & parallel mode,it can be output using the selector switch.

1) Independent Mode : 0~30V/0~3A , 0~50V/0~3A , 0~30V/0~5A independent 2 Ch.are variable.  
(TP Included Fixed 5V/3A)

2) Parallel Mode : 0 ~ 3A or 0 ~ 5A 0 ~ 6A or 0 ~ 10A output in parallel mode.

3) Serial Mode : 0 ~ 30V or 0 ~ 50V 0 ~ 60V or 0 ~ 100V output in serial mode.

C.C and C.V provide stable Current and Voltage, so you can control output value easily.

The unit is equipped with a DC output on/off function. So without turning off the power, you can control the output to minimize the damage of equipment and the load.

---

---

1

---

---

For protection ,Current limit and Over Load Protection and Over Voltage Protection functions are added.

So ,it can protect the load and instrument.

When O.L.P & O.V.P happens , the each LED Lamp is displayed.

So they can minimize the damage of equipment and the load.

When the overcurrent has happened in fixed channel(5V/3A), operating the overload protection at the same time.

And output voltage has drop and LED lamp is turned on.

To understand the statements of DC Power Supply , it has 2 digital Voltage Meter and Ampere Meter,Constant current LED (C.C) and Constant voltage LED (C.V) , OLP LED OVP LED, DC Output ON/OFF.

So you can see the statements of operation easily.

The selector switch of input power is used either for AC 115V or 230V.

---

---

2

## 2. PRECAUTIONS

### 2-1. To Replace the Fuse

Pull out F1 below with screw driver and get rid of F1, take out spare Fuse in the holder  
Put it in the position of F1.

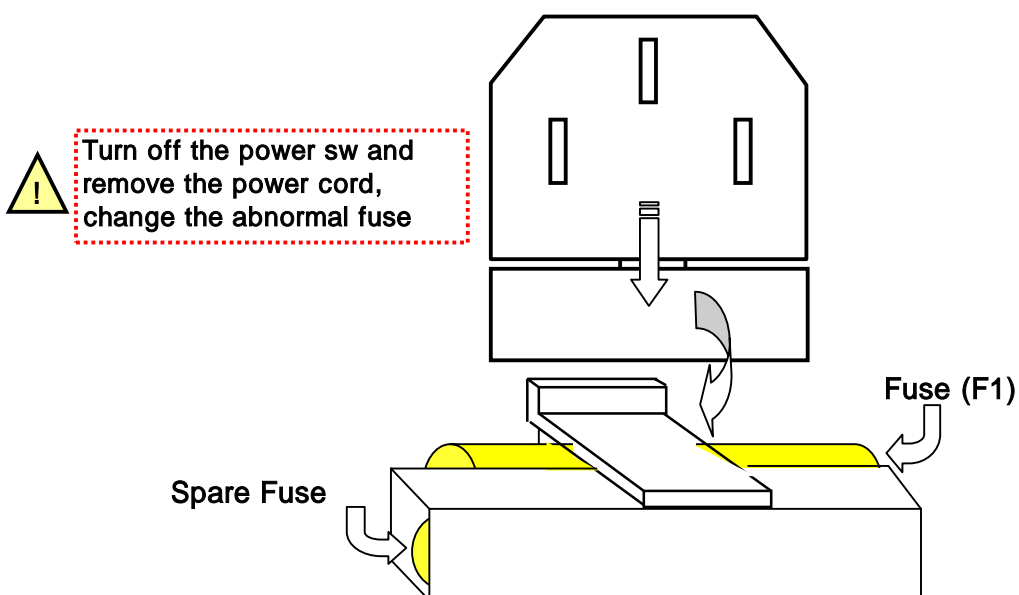

3

## Input Voltage Selection and Fuse Rating

Input Voltage	Select Switch	Fuse Number	Fuse Rate (250V)	
			1303DU/TP	1305,1503DU/TP
AC 90 ~ 110	115	F1	T4.0L	T6.3L
AC 108 ~ 132				
AC 198 ~ 242	230	F1	T1.6L	T2.5L
AC 207 ~ 250				

 For continued protection against fire, replace the line fuse only with a fuse of the specified type and rating.

4

## 2-2. INSTALLATION AND HANDLING PRECAUTIONS



When placing the Power Supply to use at your workplace, observe the following precautions for best instrument performance and longest service life.

1. Avoid placing this instrument in an extremely hot or cold place.  
Specifically, don't leave this instrument in a close car, expose to sunlight in midsummer, or to hot heater.
2. Don't use this instrument immediately after bringing it in from the cold.  
Allow time for it to warm to room temperature. Similarly don't move it from a warm place to a very cold place, as condensation might impair its operation.
3. Do not expose the instrument to wet or dusty environments.
4. Do not place liquid-filled containers (such as coffee cups) on top of this instrument.  
A spill could seriously damage the instrument.
5. Do not use this instrument where it is related to severe vibration, or strong blows.
6. Do not place heavy objects on the case, or otherwise block the ventilation holes.
7. Do not use this Power Supply in strong magnetic fields, such as near motors.

8. Do not insert wires, tools, etc. through the ventilation holes.
9. Do not leave a hot soldering iron near the instrument.
10. Do not place this instrument face down on the ground, if so, damage to the knobs may result.
11. Do not connect other power source to the output terminal.
12. Before the power switch on, you should set the voltage & current volume to the minimum (CCW)
13. Before the power switch on, don't connect the load to output terminal.(Refer to p13)

## 2-3. CLEANING

1. To clean stained casing, lightly rub the stained area with a soft cloth dipped in a neutral detergent.
2. If the surface of the panel is dirty, use the same method to clean.  
If the panel is heavily stained, rub the affected area lightly with a soft cloth soaked in light neutral detergent or alcohol.
3. Never use highly volatile material such as benzene or paint thinner.

### 3. SPECIFICATIONS

ITEMS		MODEL	GP - 1303DU/TP	GP - 1305DU/TP	GP - 1503DU/TP
Output Voltage & Current	Independent		0 ~ ±30V/0~3A	0 ~ ±30V/0~5A	0 ~ ±50V/0~3A
	Serial		0~60V/0~3A	0~60V/0~5A	0~100V/0~3A
	Parallel		0~30V/0~6A	0~30V/0~10A	0~50V/0~6A
Fixed Voltage, Current			5V/3A (TP Model only)		
C.V	Line Regulation		0.01% + 2mV		
	Load Regulation		0.01% + 3mV		
	Ripple & Noise		1mVrms		
C.C	Line Regulation		0.1% + 3mA		
	Load Regulation		0.2% + 3mA		
	Ripple & Noise		5mArms		
5V fixed output (TP only)	Voltage Accuracy		± 0.05V		
	O.L.P Lamp ON		When Current is exceeded over 110% of set Current, Voltage drops		
	Voltage drop				
	Line Regulation		5mV		
	Load Regulation		10mV		
	Ripple & Noise		2mVrms		
Meter accuracy	DC output s/w on		±(1% of rdg + 1dgt)		
	DC output s/w off		±(3dgt of rdg)		
Tracking operation	Tracking Error		0.4% + 10mV		
	Series Regulation		300mV		

7

ITEMS		MODEL	GP - 1303DU/TP	GP - 1305DU/TP	GP - 1503DU/TP
Over voltage protection			When the output voltage is exceed by approx 110% of the maximum voltage, it will be operated.		
Output on/off control			Output is produced only when power s/w and output s/w is on		
No load current limit function			Built - in		
Insulation	Classis ~ Terminal		20M or above(DC500V)		
	Clsssis ~AC Code		50M or above(DC500V)		
Temperature			0 ~ 40		
Input power source			AC110V/220V/230V , 50/60Hz		
Dimension(W x H x D)			235mm x 136mm x 370mm		
Weight(Approx)			9.8Kg	11Kg	11Kg
Accessaries			Manual , AC power cord		

8

## 4. THE DESCRIPTION OF PANEL

### 4-1. Front Panel

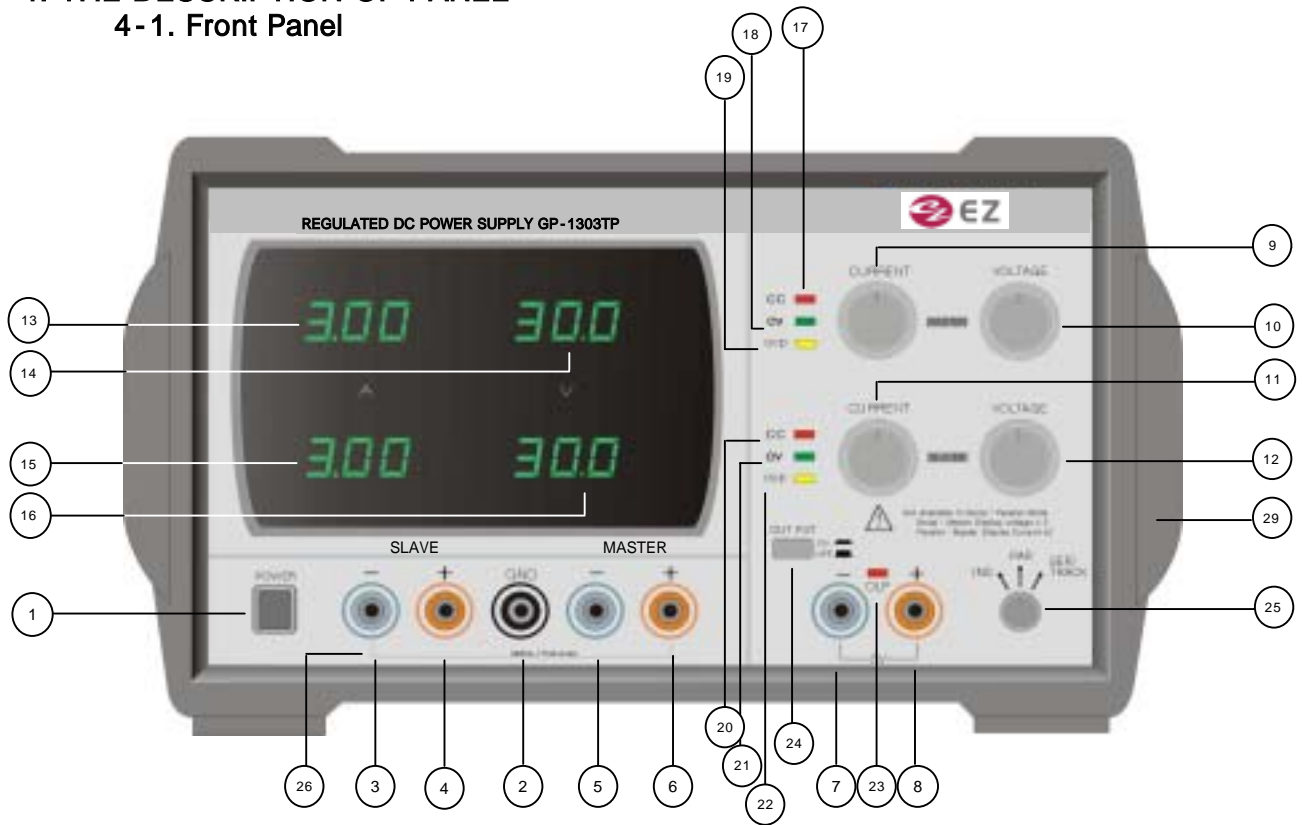

9

### 4-2. Rear Panel

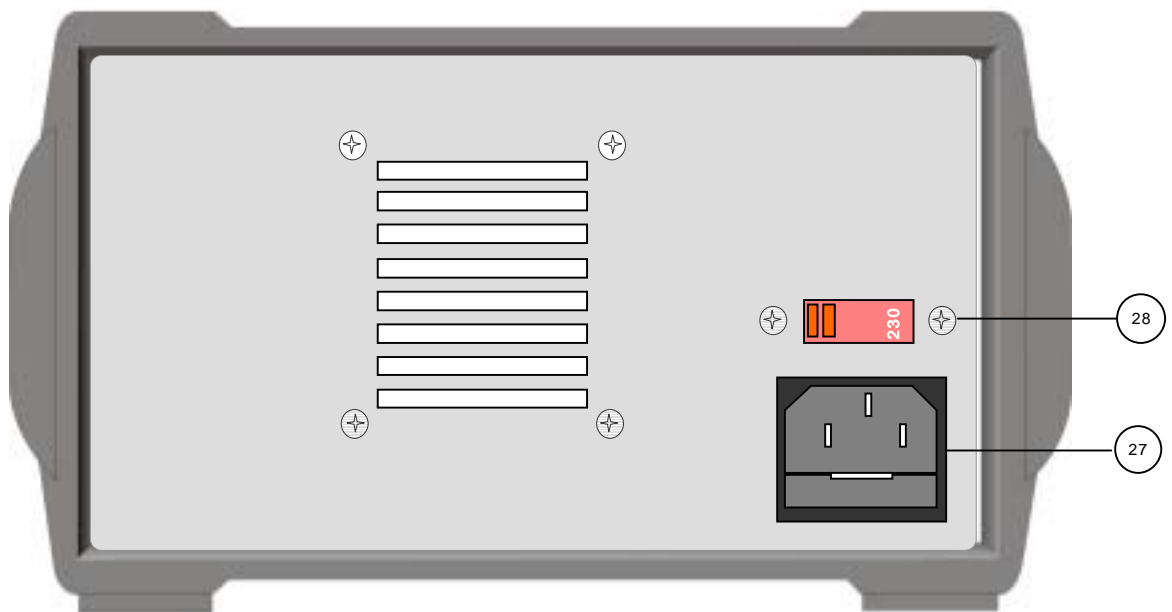

 Before the connection of AC power, you must be check selector switch and line voltage.



10

---

---

### 4-3. Description of Panel's Function

- |  |  |
|--|--|
| 1. Power Switch  | : Responsible for equipment power.   |
| 2. GND (  ) | : Chassis GROUND   |
| 3. - OUTPUT  | : Slave Channel (-) terminal.  |
| 4. + OUTPUT  | : Slave Channel (+)terminal.   |
| 5. - OUTPUT  | : Master Channel (-)terminal.  |
| 6. + OUTPUT  | : Master Channel (+)terminal.  |
| 7. - OUTPUT  | : 5V (-) terminal. ]   |
| 8. + OUTPUT  | : 5V (+) terminal. ] except for Dual Mode.   |
| 9. Master Current Knob   | : Master Current limit Control Volume  |
| 10. Master Voltage Knob  | : Master Volume limit Control Volume   |
| 11. Slave Current Knob   | : Slave Current limit Control Volume   |
| 12. Slave Voltage Knob   | : Slave Voltage limit Control Volume   |
| 13. Current Meter  | : Master Current value display   |
| 14. Voltage Meter  | : Master Voltage value display   |
| 15. Voltage Meter  | : Slave Voltage value display  |
| 16. Current Meter  | : Slave Current value display  |
| 17. C.C Display(Red)   | : Current is operated as Constant Current at master channel  |
| 18. C.V Display(Green)   | : Voltage is operated as Constant Voltage at master channel  |
| 19. O.V.P Display(Yellow )   | : It is display that flowing over 110% of max.output voltage at master channel. (output Voltage cut off at the same time.) |

- 
- 
- |                              |   |
|------------------------------|---|
| 20. C.C Display (Red )       | : Current is operated as Constant Current at slave channel.   |
| 21. C.V Display (Green)      | : Voltage is operated as Constant Voltage at slave channel.   |
| 22. O.V.P Display(Yellow)    | : It is display that flowing over 110% of max.output voltage at slave channel. (output Voltage cut off at the same time.)   |
| 23. O.L.P Display(Red)       | : That means the Current is flowed over 110% of 3A<br>Except for Dual Model   |
| 24. DC output on/off Switch: | Without turning off power switch ,it can be control the output.<br>ON(  ): Master & Slave output Value is outputed.<br>OFF(  ): Master & Slave output Value is blocked. |
| 25. Mode Selector Switch     | : Switch for exchanging of Independent,Parallel and Serial Mode   |
| 26. Serial / Parallel        | : Select Switch position is set for Serial/Parallel mode.   |
| 27. AC Power Inlet           | : Power input Socket & Fuse is set inside (Spare Fuse included)   |
| 28. Voltage Selector Switch  | : For selecting the input voltage 115 or 230V.  |
| 29. Vessel holder            | : Holder for moving instrument easily.  |

## 5. Operation

### 5-1. Checking before Operation

You should check for damage to equipment appearance (output terminal, Current and Voltage Meter, Switch, Volume and so on), check AC Power Selector Switch. If there are no problems, Connect AC Power.

### 5-2. Operational Procedure

#### 5-2-1 Independent Function

Master & Slave Function is used independently, the way of operation is same each other.

- 1) You should set DC Output S/W OFF, put the selector S/W into independent.
- 2) Connect the load into Terminal.
- 3) Turn on Power Switch.
- 4) Change Voltage, Current Knob seeing Voltage, Current Meter.
- 5) When you set the DC OUTPUT S/W ON, setting the current and voltage are output (Even though the load changes, Current won't flow over set value)
- 6) When Current goes over the set value, CC Lamp is turned on into C.C mode.

---

13

---

**Reference : If Master Channel & Slave Channel is selected to independent, the function is the same each other.**

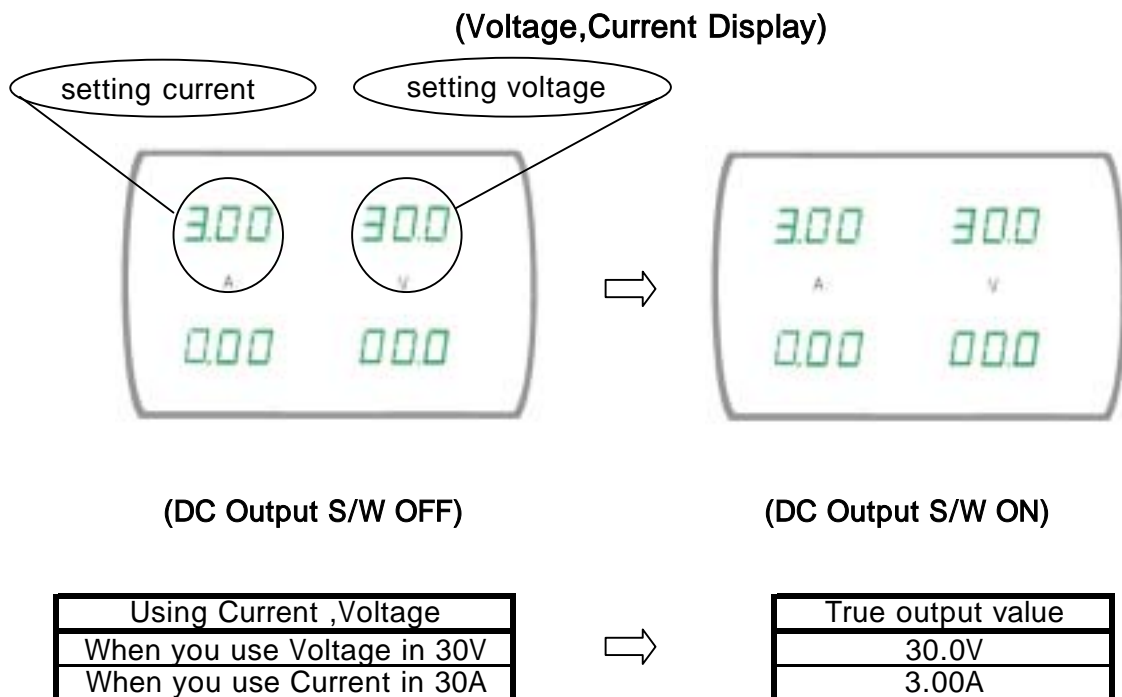

---

14

### 5-2-2 Parallel Function

Total current is sum of Master Current plus Slave Current.  
 In parallel mode slave voltage and current don't working because it's depend on master volume.

- 1) Put DC Output S/W into OFF , put the selector S/W into parallel mode.
- 2) Turn on Power Switch.
- 3) Connect the load to output terminal which is positioned in front of panel.
- 4) Watching Voltage and Current Meter, change Voltage and Current volume.  
 (Double value that is displayed on Current Meter is real Current Value.)
- 5) When DC OUTPUT S/W is ON , Double Current value of display meter is output.  
 Output voltage is the same as the display voltage meter.  
 Although the load is changed, it won't go over current limit value.

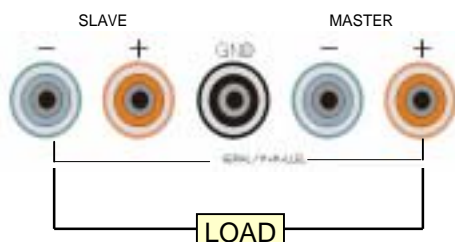
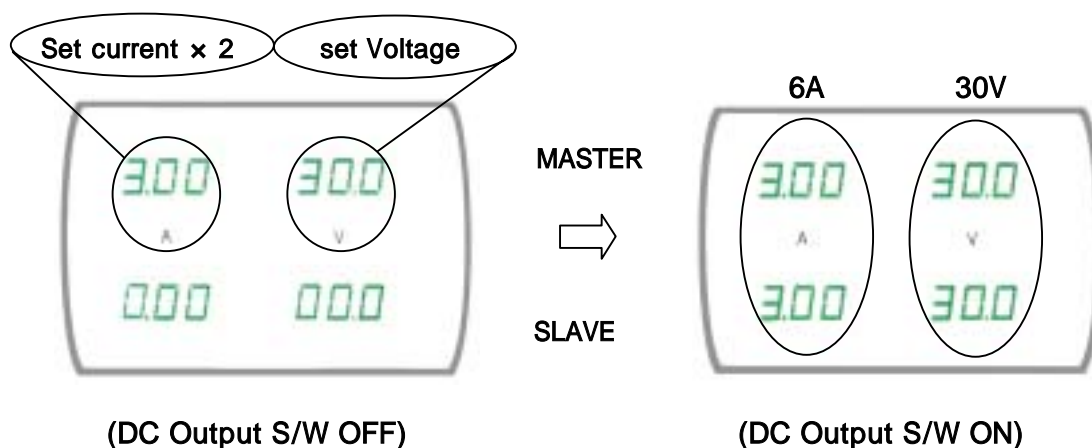

Fig. 1

### (Voltage and Current Display)



Using Current ,Voltage
When you use Voltage in 30V
When you use Current in 6A
Double of Meter Display value, so Fix in 3.00.

True output value
30.0V
3 + 3 = 6.00A

When DC OUTPUT S/W is OFF , Voltage and Current Display of Slave is always displayed "0.00" ,"00.0"

### 5-2-3 Serial Function

Total voltage is sum of Master Voltage plus Slave Voltage.

In serial mode slave voltage and current don't working because it's depend on master volume.

- 1) Put DC OUTPUT S/W into OFF , put the selector S/W into serial mode.
- 2) Connect the load to output terminal which is positioned in front of panel.
- 3) Turn on Power Switch.
- 4) Watching Voltage and Current Meter, change Voltage and Current volume.  
(Double value that is displayed on Voltage Meter is real Voltage Value.)
- 5) When DC OUTPUT S/W is ON , Double Voltage value is output.  
Output current is the same as Current Display Value.  
Although the load is changed, it won't go over current limit value.

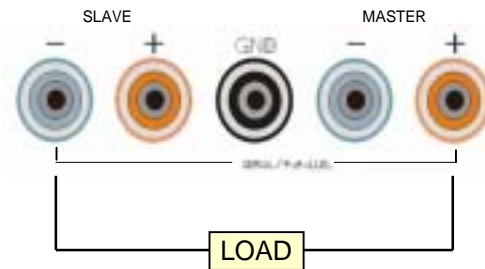
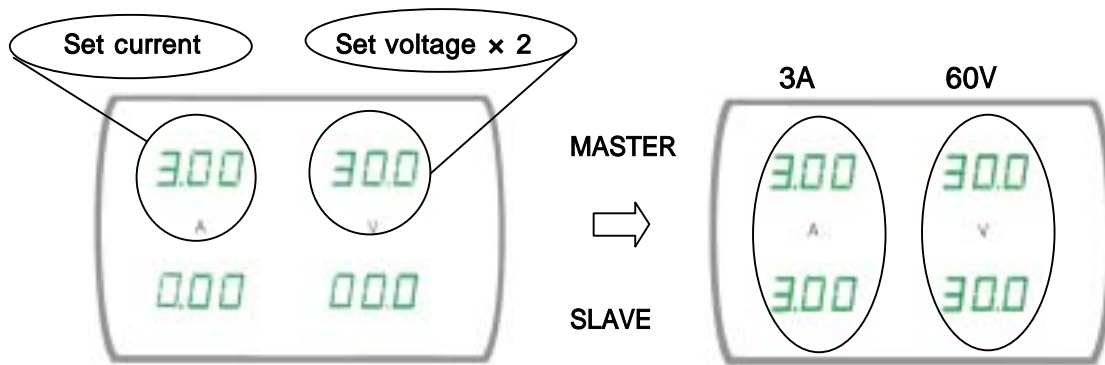

Fig. 2

### (Voltage and Current Display)



(DC Output S/W OFF Mode)

(DC Output S/W ON Mode)

Using Current ,Voltage
when you use Current in 3A
when you use Voltage in 60V
Double of Meter Display value, so Fix in 30.0.

True output value
3.00A
$30 + 30 = 60.0V$

When DC OUTPUT S/W is OFF , Voltage and Current Display of Slave is always displayed "0.00" ,"00.0"

---

## 6. 5V/3A Fixed Output

It is used to fixed power for testing the components.  
Maximum output current is 3.3A.

- 1) Turn on Power Switch.
- 2) Connect Output terminal into the load
- 3) When the Output Current goes over 110%, Output Voltage is dropped slowly, at the same time O.L.P Lamp is truned on.

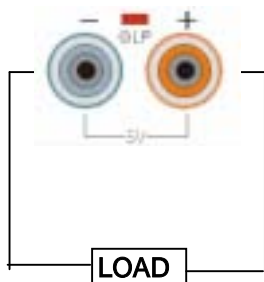

Fig. 3

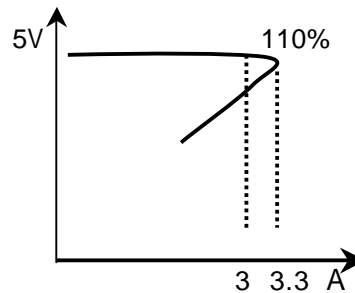

Fig. 4

---

19

---

## 7. NOTES ON ENVIRONMENTAL CONDITION

7-1 Avoid using the unit in such a place where the ambient temperature exceeds 40°C or under the direct sun.

Limit the maximum output current when the unit is used in such a place where ventilation is interrupted or radiation exists from other equipments.

7-2 Use the instrument within 10% tolerance of the specified voltage from the power source.

7-3. Environmental conditions

- 1) Indoor use
- 2) Altitude : up to 2,000m
- 3) Relative humidity :50% ~ 80%
- 4) Installation : Category (Overvoltage category)
- 5) Pollution : Degree2

---

20