

Sound Level Alert

Model SL130

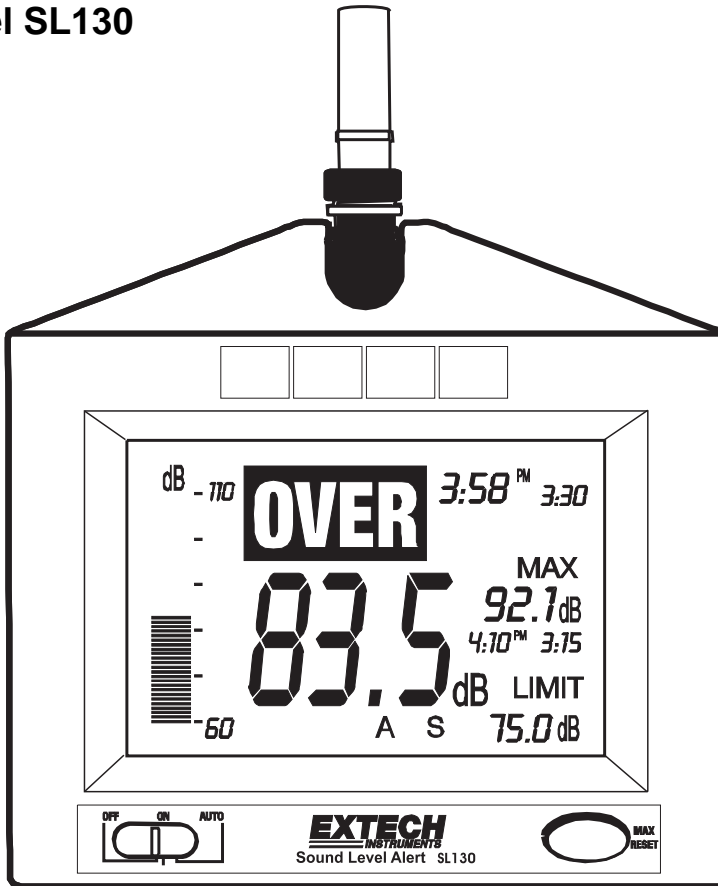

- Meets ANSI and IEC Type 2 Sound Level Meter Standards
- Settable High Limit with large bright High/Low indication and Alarm Output
- Wall or Desk mountable
- Extra large LCD display with bargraph
- Maximum level display with time stamp
- Optional alarm kit drives remote over limit indicators.



Introduction

Congratulations on your purchase of the Extech SL130 Sound Level Alert. Designed for wall mount, desk, tripod mount or hand held operation, this meter meets ANSI and IEC Type 2 Sound Level Meter standards. Included is a High/Low Limit Set Point with 4 two color high intensity LED limit exceed indicators and a large OVER indication when the set level is exceeded. An Alarm Output can be used in conjunction with the optional Alarm Module Kit to power a larger or a remote indicating device such as a "QUIET" sign. Professional features include programmable A/C Weighting and Fast/Slow Response time, Max Memory with time stamp, and a Clock display. The microphone can be rotated 180 degrees to accommodate any meter location or it can be placed at a remote location using the optional Remote Microphone Cable. A programmable ON/OFF time extends battery life to 30 days when programmed 8 hours per day. The bright LED's are functional only when the AC power adaptor is used. Careful use of this meter will provide years of reliable service.

Specifications

Applicable standards	Meets IEC 60651-1979 and ANSI S1.4 1983 Type 2 SLM standards
Display	11.7 x 7.94cm (4.6" x 3.125") multifunction LCD
Frequency bandwidth	31.5 Hz to 8 KHz
Microphone	0.5" Electret Condensor Microphone (remoteable)
Measurement ranges	30 to 80dB, 60 to 110dB, 80 to 130dB
Frequency weighting	'A' and 'C'
Response time	Fast (125ms) / Slow (1s)
Resolution	0.1dB
Max Hold	Maximum reading is displayed with time stamp
Alarm output	3.5mm Mono Phone Plug, 3.4mA @ 5 Vdc, typical
Limit range	30 to 130dB
Under range indication	"- -"
Over range indication	"OL"
Power	AC adaptor (9V@500ma) or 8 AA batteries
Battery life	240hrs continuous (approx); 30 days @ 8hrs/day (LED's are not functional when battery powered)
Operating temperature	0 to 50°C (32 to 122°F)
Operating humidity	Less than 80% RH
Dimensions / Weight	22x18x3.2cm / 285g (8.75x7.1x1.25" / 0.63 lbs).

Meter Description

1. Microphone
2. Over Limit Display
3. Bargraph
4. dB display
5. OFF/ON/AUTO switch
6. Alert LEDs
7. Clock display
8. Max level display with time stamp
9. Set limit
10. MAX RESET button

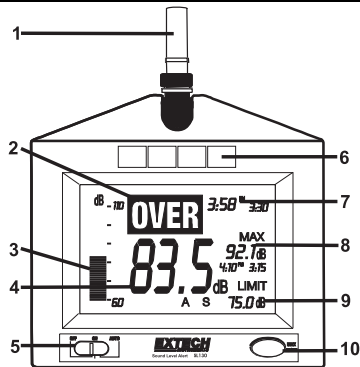

Rear Control Panel

1. Range select switch
2. Time set buttons
3. Limit set buttons
4. Calibration adjustment
5. A/C select button
6. F/S select button

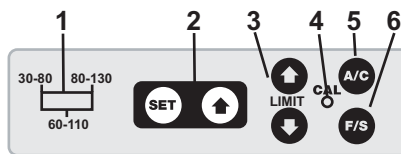

Side Panel

1. Alert switch – Green position
2. Alert switch – Red-Green position
3. Alert switch – Red position
4. High-Low Alarm switch
5. Remote Alarm output connector
6. AC adaptor connector

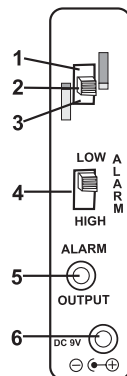

Rear Panel

1. Tilt stand
2. Battery compartment
3. AC Adaptor connector
4. Remote Alarm output connector
5. Windscreen

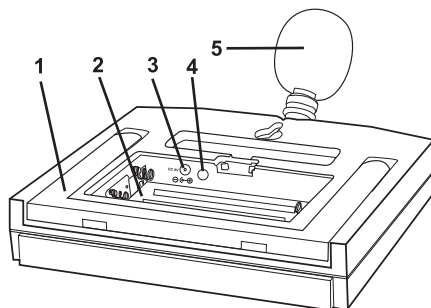

Sound Level Monitor Operation

Measurement Considerations

1. Use a windscreen to cover the microphone in windy conditions.
2. Calibrate the meter often, especially if the meter has been idle for a long period of time.
3. Do not store/operate the meter in areas of high temperature or humidity.
4. Keep the meter and the microphone dry.
5. Avoid severe vibration when using the meter.
6. Remove the battery when the meter will be stored for long periods of time.

Initial Configuration

1. Connect the AC adaptor to the side or rear AC adaptor connector
OR Install 8 AA batteries
2. Setting the TIME
 - a) Press and Hold the Time SET button until the hours display begins to flash. 
 - b) Press the Time up arrow button until the hour is set.
 - c) Press the SET button. The minutes display will flash. Adjust as needed.
 - d) Press the SET button to step through and the arrow button to adjust;

Time of day	Hour
Time of day	Minutes
Time of day	AM / PM / 24 Hour
Year	
Month	
Day	
Auto ON	Hour
Auto ON	Minutes
Auto OFF	Hour
Auto OFF	Minute

A/C Frequency Weighting

Change the Frequency Weighting by pressing the  'A/C' button. The 'A' or 'C' icon will appear on the display.

With 'A' weighting selected, the frequency response of the meter is similar to the response of the human ear. 'A' weighting is commonly used for environmental or hearing conservation programs such as OSHA regulatory testing and noise ordinance law enforcement. 'C' weighting is a much flatter response and is suitable for the sound level analysis of machines, engines, etc.

Most noise measurements are performed using 'A' Weighting and SLOW Response.

Slow/ Fast Response

Press the  button to select Fast or Slow response as desired. F or S will appear in the bottom of the LCD display.

Select FAST to capture noise peaks and noises that occur very quickly. Select the SLOW response to monitor a sound source that has a consistent noise level or to average quickly changing levels.

Select Slow response for most applications.

Range Selection

Slide the Range switch to the 30-80, 60-110 or the 80-130 position.

The selected range will be indicated on the LCD bargraph. If the measured dB level exceeds the range selected "OL" will be displayed. If the measured dB level is below the selected range "- -" will be displayed.



Normally, select the range in which the upper dB level is greater than any expected sound pressure level. The 60 to 110dB range is the most commonly used range. Use the 30 to 80dB range in quieter areas such as offices and classrooms.

Note: When the range is changed the Max display may indicate an overload "OL". Press the MAX RESET button to clear the MAX display.

High Limit Set

Press the up or down LIMIT arrow buttons to set the High/Low limit set=point as displayed on the LCD. If the measured dB level exceeds the set limit, the **OVER** indication will appear in the display and the over limit signal will appear at the alarm output connector.



The display indication and output signal will remain active as long as the sound pressure level exceeds the set limit.

High/Low LED Alert

The four LEDs are used to alert users when a sound level either exceeds or goes below the Limit set-point. This feature is available only while the AC adaptor is used to power the meter. It is disabled under battery power.

The LEDs will provide a steady or flashing colored indication depending on the setting of the side panel ALARM and Alert switch settings.

The three Alert switch positions are: (1) RED, (2) RED-GREEN, (3) GREEN

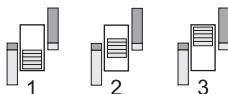

Alarm Switch	Alert Switch	LED response
High ALARM	Red (1)	LED's flash red while dB level exceeds set point.
	Red-Green (2)	LED's flash red while dB level exceeds set point. 40 second green indication when level transitions from high to low.
	Green (3)	40 second green indication when level transitions from high to low.
Low ALARM	Green (3)	LED's are green while dB level is below set point.
	Red-Green (2)	LED's are green while dB level is below set point. 40 second flashing red indication when level transitions from low to high.
	Red (3)	40 second flashing red indication when level transitions from low to high.

MAX Hold

The MAX display indicates and holds the highest dB level measured since the meter was turned on or since the Max Reset button was pressed. The time and date of the max reading is also displayed.

To clear the display and start a new measurement session, press the front panel MAX RESET button. If the measured level exceeds the maximum for the range selected the MAX display will indicate "OL" (overload).

MAX
92.7dB
4:10 PM 3:15

Programmable OFF/ON/AUTO time

The meter is powered by 8 AA batteries or via an AC adaptor for permanent installations. Continuous battery life is approximately 240 hours (10 days). By programming the ON/OFF time, the battery life can be greatly extended (30 days assuming an 8 hour day). The **ON** and **OFF** times are programmed as described in the initial configuration paragraph. The meter will operate continuously with the power switch in the ON position. The ON/OFF time will be controlled by the meter when the power switch is set to the AUTO position.

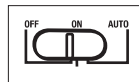

Calibration

The sound level meter should be calibrated on a regular basis to assure that the meter's performance and microphone sensitivity has not change. Some operational directives require daily calibration checks (OSHA). Extech offers several acoustic calibrators to perform the calibration.

1. Set the meter to the 60 to 110dB or 80 to 130dB range.
2. Place the external calibrator over the Sound Level Monitor's microphone and turn the Calibrator on.
3. The meter should read close to the calibrator's dB output level. Typical Calibrator output levels are 94dB and 114dB.
4. If the meter is within ± 0.2 dB of the calibrator's output, no adjustment is necessary.
5. Adjust the calibration pot on the rear of the meter to the proper level.

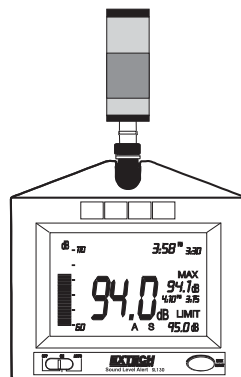

Meter Placement

The meter can be used Handheld, Wall mounted, Desk mounted or Tripod mounted. For wall mount operation, orient the microphone perpendicular to the wall to minimize the affect of acoustic reflections. For desk mounting, extend the rear legs and lock in place with the hinged locks. The tripod mounting nut is located on the bottom of the unit.



Remote Microphone (optional)

The optional 15' remote microphone cable can be used to place the microphone in one location while viewing the dB levels and/or generating a high limit alarm at another location. To remove the microphone, unscrew the holding collar and lift the microphone off the connector. The extension cable can then be plugged into the matching connectors. Calibration should be performed after the cable is installed.

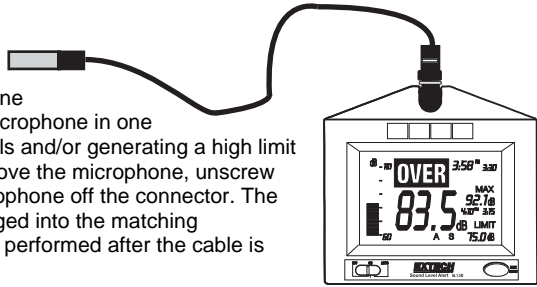

Alarm Output (optional)

The alarm output drives the optional Remote Alarm Relay Module (cable and relay) when the LIMIT set point is exceeded. The relay module can be used to power external warning signs, "QUIET" signs or other indicating devices when the sound level is higher than the programmed limit. Refer to the manual supplied with the module for connection information.

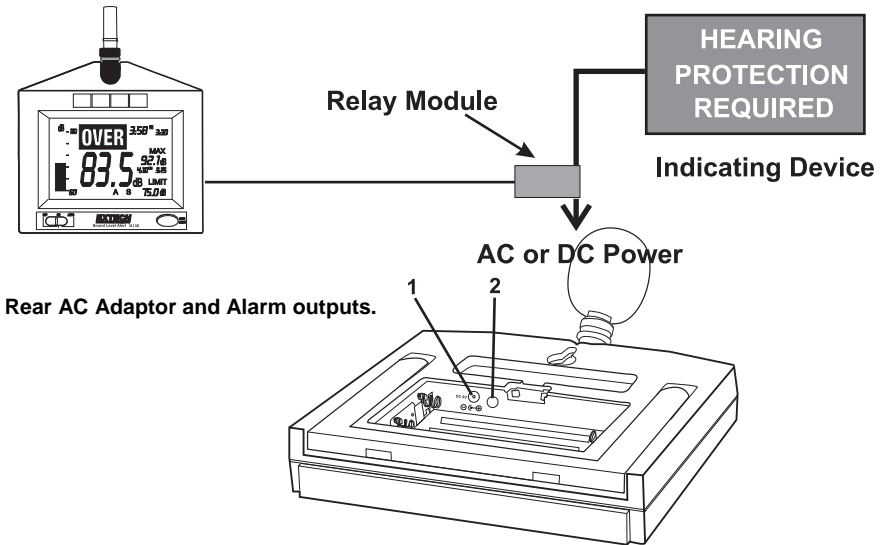

Battery Replacement

AC power is the normal power source for this meter. If 8 AA batteries are used, they are located in the rear battery compartment. When the battery icon appears on the meter's LCD, it is time to replace the batteries.

1. Turn power off.
2. Open the rear battery cover
3. Insert the batteries into battery holder, observing the correct polarity.
4. Put the battery cover back in place.