

User's Guide



▶ Visit us at www.TestEquipmentDepot.com
▶ Back to the Exttech 480823 Product Page

Electromagnetic Field Meter

Model 480823

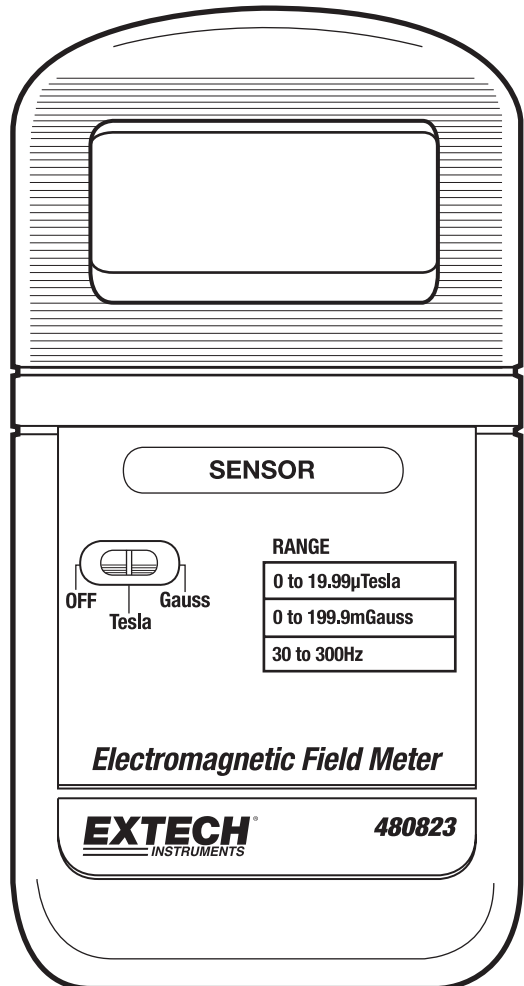

Introduction

Congratulations on your purchase of Extech's Electromagnetic Field Meter, model 480823. This battery powered meter measures and displays EMF in Gauss and Tesla units with a frequency bandwidth of 30 to 300Hz. This professional meter, with proper care, will provide years of safe reliable service.

Specifications

Display	0.5" (13mm) 3-1/2 digit (1999 count) LCD with low battery and overload indication
Measurement rate	Approx. 0.4 seconds
Maximum ranges and resolution	19.99 μ Tesla (0.01) and 199.9mGauss (0.1) NOTE: 1 μ Tesla = 10 milli-Gauss
Accuracy	\pm (4% + 3 digits) @ 50/60Hz
Frequency bandwidth	30 to 300Hz (single axis measurements only)
Over-range indication	"1___" is displayed
Operating Temperature/Humidity	Temperature: 32 to 122°F (0 to 50°C) RH: 90% max. (0 to 35°C); 80% max. (35 to 50°C)
Power source	9V Battery
Power consumption	Approx. 3mA DC
Dimensions	5.2 x 2.8 x 1" (131 x 70 x 25mm)
Weight	0.36 lbs. (165g)

Meter Description

1. LCD display
2. EMF Sensor
3. Power/Units switch

Note that the tilt stand and battery compartment are located on the rear of the meter

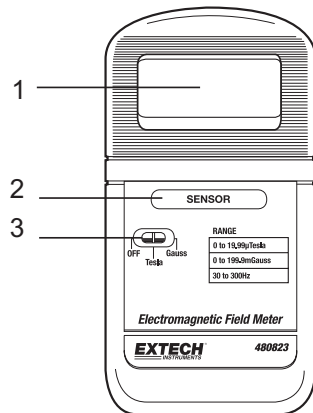

Meter Operation

1. Place the "OFF/Tesla/Gauss" Switch to the Gauss or Tesla position.
2. Move the meter's sensor slowly toward the device under test and read the LCD indication. If the LCD display is completely blank or if "LO BAT" appears on the left corner of the LCD, check the 9V battery (replace if necessary).
3. Notice that the field intensity reading increases as you move closer to a field.
4. Position the meter at different angles to the device under test and observe how this positioning affects the EMF readings.
5. Record the highest reading obtained from the various reading positions.
6. If the device under test is off, the EMF tester reading should go to zero unless another source of radiation is present.
7. If the meter's display indicates a "1" on the left side of the LCD, an overload condition exists. This indicates that the measured radiation is higher than the capability of the meter.

EMF Exposure

The effect of EMF exposure on humans and animals is a modern day concern. At the time of this writing, to the best of our knowledge, no standards or recommendations exist regarding limits of EMF exposure. Until evidence suggests that there is not a health risk associated with EMF exposure, common sense would dictate that a practice of minimal exposure be exercised.

Battery Replacement

When the low battery message "LO BAT" appears on the left corner of the LCD, the 9V battery has fallen to a critically low voltage level and should be replaced as soon as possible. The battery compartment cover is located at the bottom rear of the meter. Slide off the battery compartment cover, change the battery, and replace the compartment cover.