

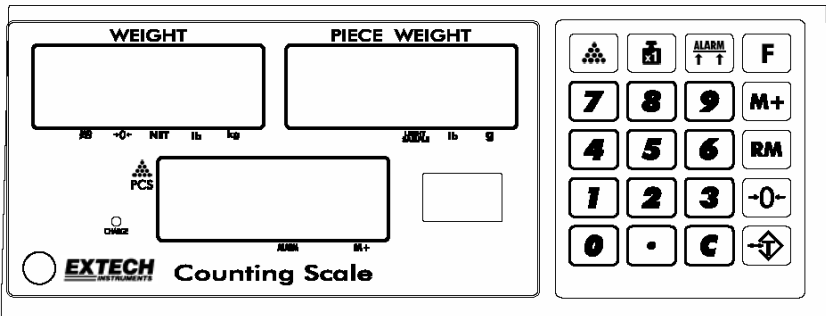

# Precision Counting Scale With RS232 Interface

## Models 160272 and 160275



## Introduction

---

Congratulations on your purchase of the Extech 160272 / 275 Counting Scale. This scale, with proper care, will provide years of safe reliable service.

## Specifications

---

	<b>160272</b>	<b>160275</b>
<b>Range</b>	6 lbs. / 3 kg	15 lbs. / 7.5 kg
<b>Resolution</b>	0.0005 lbs. (0.0002 kg)	0.002 lbs. (0.0005 kg)
<b>Accuracy</b>	0.01%FS + 2 digits	
<b>Pan Size</b>	10.2 x 7.9" (259 x 201mm)	
<b>Dimensions</b>	10.6 x 13 x 4.5" (269 x 330 x 114mm)	
<b>Net Weight</b>	10 lbs. (4.6 kg)	
<b>Power</b>	9V (500mA) AC Adapter/Charger	

## Disclaimer Notice

---

Calibrate the scale using reference weights of the appropriate tolerance (class). An instrument can be no more accurate than the standard to which it has been compared.









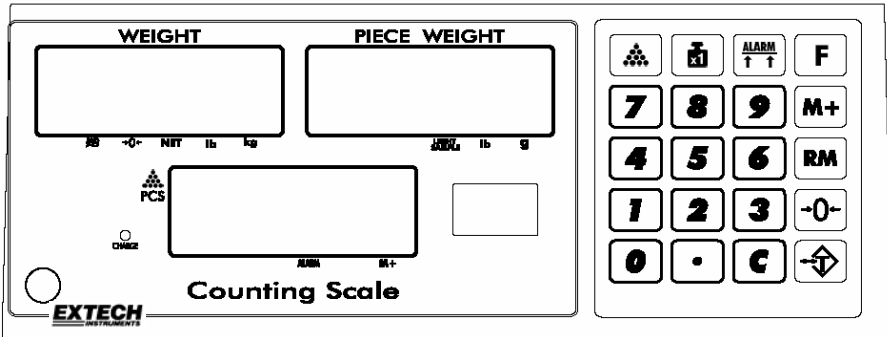



## Preparation

---

- Select a suitable work area (this product is intended for indoor use).
- The work area should be relatively free from drafts and vibrations.
- The work surface should be level and rigid.
- Do not locate the scale near magnetic materials or equipment/instruments which use magnets in their design.
- Avoid areas that have large variations in temperature. Also, room temperatures above 104°F or below 32°F could affect instrument.

## Scale Description



- 

 Numeric keys. Used for setting numeric data for tare weight, sample number, sample weight, or limit
- 
 Sets a new zero reference.  
Cancels the stored data in total mode
- 
 Set the gross weight on the pan to the tare weight
- 
 Set the decimal point for the tare or sample weight
- 
 Cancels the numeric data or the Piece Weight data
- 
 Used for Parts counting mode
- 
 Sets the known piece weight data
- 
 Used to toggle between normal counting and checking operations
- 
 Used when accumulating sub-total data and for various printing operations
- 
 Used to toggle between normal counting and memory recall modes
- 
 Function key for lbs/kg selection

### Getting Started

- a. Power the scale by connecting the AC Adaptor / Charger to the power jack on the bottom right side of the scale and to the AC source. Turn the scale on via the power switch. The power switch is located on the bottom right side of the scale. Once the internal 9V battery is charged, the scale can be used without the adaptor connected.
- b. Upon start-up, the display will count down from '999999'.
- c. Allow the scale to warm-up for 30 minutes.



### Taring (Zeroing)

Each model has tare capability up to its total weight capacity. For reducing the tare weight from the scale there are two methods:

#### 1. Push button tare

- a. Place sample container on pan and then press the  key. The NET indicator will turn on and the WEIGHT display will show zero.
- b. Now place the sample in its container.
- c. When the scale display is stable it shows the weight of the sample.

#### 2. Keyboard tare

- a. Set the known tare weight using the numeric keypad. Do not enter the decimal point. The data is displayed in the flashing PIECE WEIGHT display.
- b. Press the  key.
- c. This sets the tare weight displayed in the WEIGHT display to zero. This also clears the previous tare.
- d. Remove weight from pan then press the  key, so that the NET indicator switches off and the WEIGHT display returns to zero.

### Counting Function

There are two setting methods: PIECE COUNT and PIECE WEIGHT.

#### 1. Piece Count Setting

- a. Count the desired number of sample pieces (10, 20, 50, 100, or 200 total pieces), placed on the pan. The total weight is shown on the WEIGHT display.
- b. Set the number of samples using the numeric keys. The number is shown on the flashing PIECE WEIGHT display.
- c. Press the  key, the PIECE WEIGHT display shows the average piece weight and the QUANTITY display shows the sample number.

#### 2. Piece Weight Setting (Use this method if the piece weight is known)

- a. Set the piece weight using the numeric keys and the decimal point key. The number is shown on the flashing PIECE WEIGHT display.
- b. Press the  key, to complete the PIECE WEIGHT setting.

The Piece weight alarm 'LIGHT SAMPLE' indicator will flash when the average piece weight or set piece weight is not sufficient for accurate counting. The scale may still be used in this case but counting errors may occur.

## Accumulation Function

1. Press the **M+** key to accumulate the sub-total piece count (M+ appears on display).
2. Return the scale to zero before accumulating a new piece count.
3. Press the **RM** key to toggle between normal counting and memory recall.

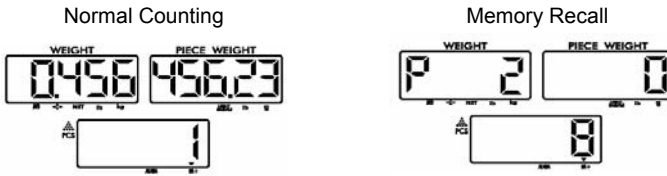

Note: The **→0←** key can be used to delete the grand total.

## Alarm Functions

### 1. Alarm Setting

This function is designed for packing applications. For example, if the user wishes to pack 100 pieces in each carton, the upper limit can be set to 100 pieces.

- a. Press the **ALARM** key
- b. Press the **1 0 0** keys and then the **SET** key
- c. Press the **ALARM** key, to return to normal counting mode.
- d. The Alarm indicator will turn ON.
- e. Now if the total quantity reaches 100 or more the scale will emit a series of beeps.

### 2. Alarm Release

- a. Press the **ALARM** key
- b. Press the **C** **SET** keys and the **ALARM** key
- c. The indicator will turn off.

## Programming

---

Press and hold any key while turning the scale on. The display will show CAL

Press 3 to access the program sequence.

Press ☒ to sequence through the available parameters.

Press ↔ to change settings and advance to the next step (see below):

Auto Power Off	<span style="border: 1px solid black; padding: 2px;">P0</span>	<span style="border: 1px solid black; padding: 2px;">0</span>	Off
	<span style="border: 1px solid black; padding: 2px;">P0</span>	<span style="border: 1px solid black; padding: 2px;">1</span>	After 5 minutes
	<span style="border: 1px solid black; padding: 2px;">P0</span>	<span style="border: 1px solid black; padding: 2px;">2</span>	After 10 minutes
	<span style="border: 1px solid black; padding: 2px;">P0</span>	<span style="border: 1px solid black; padding: 2px;">3</span>	After 20 minutes
	<span style="border: 1px solid black; padding: 2px;">P0</span>	<span style="border: 1px solid black; padding: 2px;">4</span>	After 30 minutes
Backlight	<span style="border: 1px solid black; padding: 2px;">P1</span>	<span style="border: 1px solid black; padding: 2px;">0</span>	Off
	<span style="border: 1px solid black; padding: 2px;">P1</span>	<span style="border: 1px solid black; padding: 2px;">1</span>	On
	<span style="border: 1px solid black; padding: 2px;">P1</span>	<span style="border: 1px solid black; padding: 2px;">2</span>	Auto lighting while loading
RS232 Output	<span style="border: 1px solid black; padding: 2px;">P2</span>	<span style="border: 1px solid black; padding: 2px;">0</span>	Off
	<span style="border: 1px solid black; padding: 2px;">P2</span>	<span style="border: 1px solid black; padding: 2px;">1</span>	Enabled

## Error Messages

---

<i>Display</i>	<i>Cause</i>	<i>Solution</i>
<span style="border: 1px solid black; padding: 2px;">r-----r</span>	<b>Overload</b> Weighing range exceeded	Unload scale
<span style="border: 1px solid black; padding: 2px;">l-----l</span>	<b>Underload</b> Weighing pan not in place Weighing range is below zero	Ensure pan is in place set scale to zero
<span style="border: 1px solid black; padding: 2px;">-OL-</span>	<b>Zeroing not possible</b> Zeroing outside the zero setting range	Perform zero in admissible range

## RS232 Specifications & Connections

The scale comes with a uni-directional RS232 port allowing the scale to transmit data to a PC via a communication program such as Hyper Terminal. The physical connection is made via the COM port through a 9 pin data cable.

Hyper Terminal Settings:

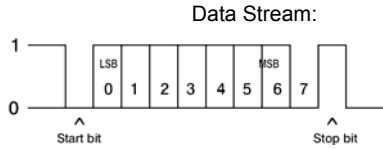
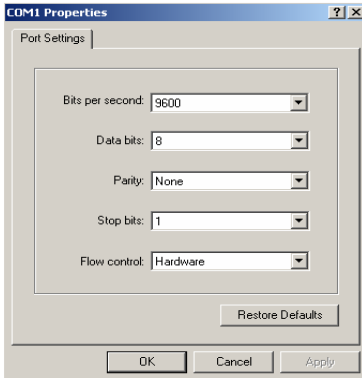

Once Hyper Terminal link has been completed, select PROPERTIES from the Hyper Terminal menu and change settings as shown.

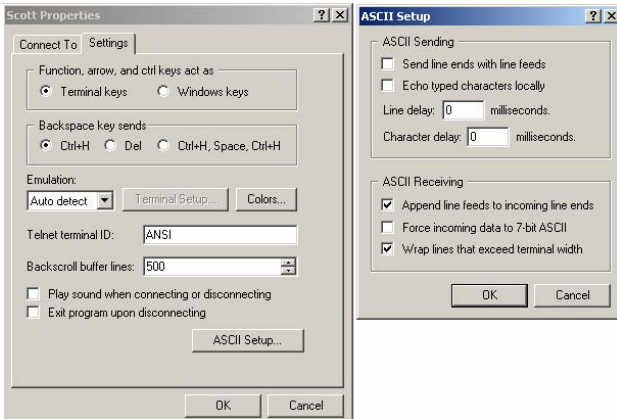

To transmit from the scale to the PC press the **M+** key.  
Data transmitted will appear in the following format.

```
ID : XXXXXXXXXXXX
WT : XXXXX LB
APW1000 : XXXXX LB
QTY : XXXXXX PCS
```