

GE
Sensing & Inspection Technologies

Druck DPI 620

advanced modular calibrator

user manual - K0449



Quick reference data

A1.1 DPI 620: Channel 1 (CH1)

Measure (M) / Source (S) / Power (P)	
±30 V (M)	±55 mA (M)
0 to 12 V (S)	0 to 24 mA (S)
±2000 mV (M) 0 to 2000 mV (S)	8 RTDs (M/S): Pt1000, Pt500, Pt200, Pt100(385), Pt50, D 100, Ni 100, Ni 120
0 to 4000 Ω (M/S)	12 Thermocouples (M/S): K, J, T, B, R, S, E, N, L, U, C, D
0 to 50 kHz (M/S)	⚠ 20 Vrms (M): voltage connectors on CH1 only.
Switch (M) 	⚠ 2000 mV rms (M): voltage connectors on CH1 only.
	⚠ 300 Vrms, 50 Hz to 400 Hz (M). Only with the AC probe; see Section 3.2.5.

A1.2 DPI 620: Channel 2 (CH2)

±30 V (M)	0 to 24 mA (S)
±2000 mV (M)	24 V loop (P); maximum: 24 mA
±55 mA (M)	Switch (M) 

A1.3 DPI 620 + MC 620 + PM 620

Pressure* (M)	
Gauge: 25 mbar to 200 bar (0.36 to 3000 psi) Absolute: 350 mbar to 1000 bar (5 to 15000 psi)	
Note: Maximum pneumatic pressure: 500 bar (7250 psi)	

***Caution: To prevent damage to the PM 620 module, only use it within the specified pressure limit on the label.**

Copyright

© 2008 General Electric Company. All rights reserved.

Trademarks

Microsoft and Windows are either registered trademarks or trademarks of Microsoft Corporation in the United States and/or other countries.

HART is a registered trademark of the HART Communications Foundation.

All product names are trademarks of their respective companies.

Safety

Before you use the instrument, make sure that you read and understand all the related data. This includes: the applicable local safety procedures, this publication, and the instructions for the accessories/options/equipment you are using it with.

General warnings

WARNING

- **It is dangerous to ignore the specified limits for the instrument or its related accessories. Do not use the instrument or accessory if it is not in its normal condition. Use the applicable protection and obey all safety precautions.**
- **Do not use the instrument in locations with explosive gas, vapour or dust. There is a risk of an explosion.**

Electrical warnings

- **To prevent electrical shocks or damage to the instrument, do not connect more than 30V between the terminals, or between the terminals and the ground (earth).**
- **To prevent electrical shocks, use only the GE specified AC probe (Part: IO620-AC) to measure AC voltages that are more than 20 Vrms (maximum: 300 Vrms). Attach it to the specified connections only.**
- **This instrument uses a Lithium-Polymer (Li-Polymer) battery pack. To prevent an explosion or fire, do not short circuit, do not disassemble, keep it safe from damage. For operating conditions, see [Table 10-1](#).**
- **To prevent battery leakage or heat generation, only use the battery charger and power supply in the temperature range 0 to 40°C (32 to 104°F). For operating conditions, see [Table 10-1](#).**
- **To make sure the display shows the correct data, disconnect the test leads before you set the power to on or change to another measure or source function.**

Pressure warnings

If you use a pressure option with the DPI 620 calibrator, these warnings are also applicable:

- **Some liquid and gas mixtures are dangerous. This includes mixtures that occur because of contamination. Make sure that the equipment is safe to use with the necessary media.**

Continued

- **Pressurized gases and fluids are dangerous. Before you attach or disconnect pressure equipment, safely release all the pressure.**
- **To prevent a dangerous release of pressure, make sure that all the related pipes, hoses and equipment have the correct pressure rating, are safe to use and are correctly attached.**
- **It is dangerous to attach an external source of pressure to a PV 62x series pressure station. Use only the specified mechanisms to set and control the pressure in the pressure station.**











Cautions

Caution: To prevent damage to the display, do not use sharp objects on the touch-screen.

To prevent damage to the PM 620 module, only use it within the specified pressure limit on the label.

Before you start an operation or procedure in this publication, make sure that you have the necessary skills (if necessary, with qualifications from an approved training establishment). Follow good engineering practice at all times.

Marks and symbols on the instrument

	Complies with European Union directives		Warning - refer to the manual
	Read the manual		USB ports: Type A; Mini Type B connector
	Ground (Earth)		ON/OFF
	Slot for a micro Secure Digital (SD) WiFi card*		Slot for a micro-SD memory card
	DC adaptor polarity: the centre of the plug is negative.		
	Do not dispose of this product as household waste. Refer to Chapter 9 (Maintenance procedures) .		
More marks and symbols are specified in this manual: electrical marks, display symbols (Chapter 1); pressure related marks and symbols (Chapter 4).			

* The micro WiFi card is not yet available but WiFi functions are available with part number: DPI 620 CE WIFI

Overview

The advanced modular calibrator (AMC) is part of a set of hand-held modules that you can quickly put together to include a wide range of calibrator functions.

Advanced modular calibrator, DPI 620 (this user manual):

This is a battery-powered instrument for electrical measure and source operations and HART® communications; see [Table A1](#) (front cover). It also supplies the power and user interface functions for all the add-on modules. You can use the touch-screen to display up to six different parameters.



DPI 620

Pressure module carrier, MC 620 (this user manual):

This attaches to the DPI 620 calibrator to make a fully integrated pressure indicator instrument. To measure and display pneumatic or hydraulic pressures, you can have up to two interchangeable pressure modules at a time.



MC 620

Pressure modules, PM 620 (this user manual): These modules attach to the pressure module carrier (MC 620) or to a pressure station (PV 62x) to give the DPI 620 calibrator the necessary pressure measurement functionality. They are fully interchangeable “plug and play” modules with no initial set-up or user calibration.



PM 620

Pressure stations, PV 62x (user manual - K0457): There are three pressure stations:

- two pneumatic pressure stations to give you accurate and controlled pressure and vacuum conditions:

PV 621: -950 mbar to 20 bar (-13.5 to 300 psi) version

PV 622: -950 mbar to 100 bar (-13.5 to 1500 psi) version

- one hydraulic pressure station to give you accurate and controlled hydraulic pressure conditions:

PV 623: 0 to 1000 bar (15000 psi)

You can attach the DPI 620 calibrator and a PM 620 module to make a fully integrated pressure calibrator instrument.

To give the attached equipment overpressure protection, there are pressure relief valves (PRV) available for all the pressure stations.

Software (this user manual): The DPI 620 calibrator includes the following software:

- documenting software
- HART® communications software



Pressure calibrator

Other accessories and options: For part numbers (P/N), refer to [Section 1.4 \(Accessories\)](#).

Summary of functions

This table gives a summary of the available functions with the DPI 620 calibrator.

DPI 620 - Calibrator functions

Function
Easy to read liquid crystal display (LCD) in colour
No keys: the touch-screen has large buttons for finger operation.
Rechargeable lithium polymer battery with enhanced power control for prolonged battery life.
* Measure current (mA), voltage (Volts/mV), frequency (Hz/pulse count)
* Supply current (mA), voltage (Volts/mV), frequency (Hz/pulse count)
* Measure/simulate: <ul style="list-style-type: none"> - a Resistance Temperature Detector (RTD): Ω or $^{\circ}\text{C}/^{\circ}\text{F}$ - a thermocouple (TC): mV or $^{\circ}\text{C}/^{\circ}\text{F}$ - a resistor (Ω)
Cold Junction (CJ) compensation: Automatic/Manual
Step/Ramp functions: Automatic/Manual
Switch test and condition indicator (open/closed)
Language selection (see Section 2.10 (Menu sequence))
Universal Serial Bus (USB) communications ports: For computer communications, external modules, flash memory drives
Micro SD memory slot: up to 4 GB of additional memory
† WiFi model for wireless operation
† Windows® CE operating system
** Measure pressure/Leak test: See pressure accessories
Documenting software to give an analysis of a device calibration
Setup function to save and recall personal settings, instrument calibration settings and other standard instrument operations.

DPI 620 - Calibrator functions (Continued)

Function
HART [®] (Highway Addressable Remote Transducer) communications software to set up and calibrate devices that use the HART field communications protocol.
Other functions: Hold, maximum/minimum/average, filter, tare, adjustable backlight, adjustable volume for the sound port, alarm indication (on the display and from the sound port), automatic power off.

* Refer to the datasheet

** Optional item

† Factory configured

About this manual

This user manual is set up for you to use on a computer or similar device that has the necessary software to read a Portable Document Format (PDF) file.

It is supplied as a PDF on a compact disc (CD) but you can copy or save the PDF onto a computer or similar device that has the necessary PDF software.

To navigate between related items of information, the user manual includes cross references and links (shown in blue); for example:

- text cross references: ... [Figure 1-1](#); [Table 10-1](#); [Chapter 1](#); [Section 1.4 \(Accessories\)](#)

Note: If you move the PDF software cursor over an item that has a link, the cursor symbol normally changes.

When you click on a link, your PDF software shows the applicable page. To help you navigate through the links you use, your PDF software usually includes these buttons:

Example buttons:



Previous view: To go back to a previous page selection.



Next view: In a sequence of page selections, this takes you forward to the next page.

Note: Different software versions have different buttons. In some versions, it is also necessary to set up the “View” to include these “Tools” in the “Page Navigation Toolbar”; refer to your PDF software documentation.

Table of Contents

Quick reference data	ii
Trademarks	ii
Safety	iii
Overview	v
Summary of functions	vi
About this manual	vii
Table of Contents	ix
Chapter 1: Instrument parts, accessories and options	
1.1 Introduction	1-1
1.2 The instrument	1-1
1.3 The display	1-3
1.4 Accessories	1-4
Chapter 2: Prepare the instrument	
2.1 Introduction	2-1
2.2 Initial checks	2-1
2.3 Initial procedures	2-1
2.4 Power options	2-1
2.5 The battery	2-2
2.5.1 Battery condition	2-2
2.5.2 Install the battery	2-2
2.5.3 Charge the battery	2-3
2.5.4 Charge times	2-3
2.5.5 Operating time	2-3
2.6 The DC power supply	2-3
2.7 The USB power supply	2-4
2.8 Power on or off	2-4
2.9 Display operation	2-5
2.9.1 Change items in a list	2-5
2.9.2 Change numeric values	2-5
2.9.3 Enter text	2-6
2.9.4 Maximise/minimise a window	2-6

2.10 Menu sequence	2-7
2.10.1 Procedure to set the basic operations:	2-8
2.10.2 Procedure to see the instrument status	2-8
2.10.3 Procedures to make Task selections	2-9
2.10.4 Set a function	2-10
2.10.5 Set the units	2-11
2.10.6 Set up a utility:Maximum/Minimum/Average example	2-11
2.11 Measure and source operations.	2-12
2.11.1 Set the Process options (measure)	2-13
2.11.2 Set the Automation options (source)	2-15
2.11.3 Set the Observed settings (source)	2-16
2.12 The Advanced menu options	2-17
2.12.1 Advanced: Calibration options	2-17
2.12.2 Advanced Setup options.	2-19
2.13 The Help menu	2-19
 Chapter 3: Electrical and IDOS operations	
3.1 Introduction	3-1
3.2 Measure and source operations.	3-1
3.2.1 Procedure overview	3-1
3.2.2 Example procedure: Measure or source current	3-2
3.2.3 Example procedure: Measure DC voltage	3-3
3.2.4 Example procedure: Measure AC voltage (CH1), 0 to 20 Vrms only	3-3
3.2.5 Example procedure: Measure AC voltage (CH1) with the AC probe	3-4
3.2.6 Example procedure: Source DC voltage (CH1)	3-5
3.2.7 Example procedure: Measure or source current with internal 24V loop power	3-5
3.2.8 Example procedure: Measure or source frequency signals	3-6
3.2.9 Example procedure: Measure or simulate an RTD (or Resistance)	3-7
3.2.10 Example procedure: Measure or simulate a thermocouple (or TC mV)	3-8
3.2.11 Example procedure: Switch test	3-9
3.3 Measure pressure: IDOS option.	3-10
3.3.1 Assembly instructions	3-11
3.3.2 IDOS function procedures	3-11
3.3.3 Example procedure: Measure pressure with an IDOS module.	3-12
3.4 Error indications	3-13

Chapter 4: Pressure indicator operation (MC 620)

4.1 Introduction	4-1
4.2 Parts and assembly	4-1
4.2.1 Assembly instructions	4-2
4.3 Pressure connections	4-2
4.3.1 Procedure (to attach external equipment)	4-2
4.4 Measure pressure	4-3
4.4.1 Procedure overview	4-3
4.4.2 Set up a Leak Test	4-4
4.4.3 Set the pressure module to zero	4-5
4.4.4 Example procedure: Measure pressure	4-5
4.5 Error indications	4-6

Chapter 5: Instrument communications

5.1 Introduction	5-1
5.2 Connect to a computer (USB)	5-1

Chapter 6: Datalog operation

6.1 Introduction	6-1
6.2 Set-up	6-1
6.3 Data Logging	6-3
6.4 Data handling	6-3

Chapter 7: Documenting functions

7.1 Introduction	7-1
7.2 Analysis	7-1
7.3 Run a procedure	7-2
7.3.1 Sequence to upload and download file	7-3

Chapter 8: HART® device operations

8.1 Introduction	8-1
8.2 About HART	8-1
8.3 Available HART commands	8-2
8.4 HART Connections	8-4
8.4.1 Power supply from the calibrator	8-4
8.4.2 External loop power	8-5
8.4.3 Communicator attached to a network	8-6

8.5 Start HART menu operations	8-8
8.5.1 HART menu - Information (Sensor, Hardware, Settings)	8-8
8.5.2 HART menu - Information (Advanced, Clone)	8-9
8.5.3 HART menu - Calibrate and Loop Test	8-10
 Chapter 9: Maintenance procedures	
9.1 Introduction	9-1
9.2 Clean the unit	9-1
9.3 Replace the batteries	9-1
 Chapter 10: General specification	
10.1 Introduction	10-1
Customer service	Back cover

Chapter 1: Instrument parts, accessories and options

1.1 Introduction

This chapter gives a description of the different parts of the instrument and the accessories/options available.

1.2 The instrument



Figure 1-1: General view of the instrument

1.	On or off button. Press and hold the button down until the display comes on.
2.	Channel 1 (CH1) and channel 2 (CH2) connectors for electrical operations; see Figure 1-2 .
3.	Rubber pull-down cover for the USB type A connector; USB mini type B connector and +5V DC power input socket; see Figure 1-3 .
4.	Colour display with touch-screen. The number of windows you see on the display is set by the number of task selections and external modules you are working with (maximum: 6); see Section 2.9 (Display operation) . To make a selection, lightly tap on the applicable display area with a finger.
5.	Sealed speaker unit.

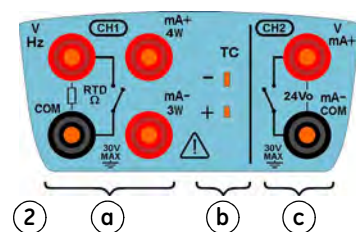

Figure 1-2: CH1/CH2 connections

2a	Channel 1 (CH1) connectors for: V: volts/mV DC or AC*; Hz: frequency and counts/min, counts/hour (cpm/cph); Ω: resistance; RTD: 2-wire, 3-wire (3W), 4-wire (4W) resistance temperature detectors; Ω : switch operation; mA+ , mA- : current. Refer to Chapter 3 (Electrical and IDOS operations) .
2b	Channel 1 (CH1) connectors for thermocouples (TC). Refer to Chapter 3 .
2c	Isolated channel 2 (CH2) connectors for: V: volts/mV DC; mA+ , mA- : current; 24Vo: 24V loop power supply; Ω : switch operation; refer to Chapter 3 . For HART connections, refer to Chapter 8 .

(COM = Common)

Note: * You can measure an AC voltage (maximum: 20 Vrms) without the GE specified AC probe (P/N IO620-AC). If it is more than 20Vrms, you must use the AC probe (maximum: 300 Vrms) in CH1 connectors V/Hz and COM; see [Section 3.2.5](#).



Figure 1-3: The USB and power sockets



3a	 : USB type A connector for connections to external peripherals (USB flash memory or optional external modules).
3b	 : USB mini Type B connector for communication with a computer. The optional USB mini Type B cable also supplies power to the instrument; see Section 2.4 (Power options) .
3c	 : +5V DC power input socket. This supply also charges the battery. Refer to Section 2.5.3 .



Figure 1-4: Bottom view (cover attached)

6.	Cover for the USB connectors and the DC power input socket (Figure 1-3). For IP65, press it fully into the recess over the connectors.
7.	Two connection points to attach the pressure module carrier (MC 620); refer to Chapter 4 (Pressure indicator operation (MC 620)) .
8.	Electrical connections for the pressure module carrier (MC 620) or a pressure station (PV 62x).
9.	Label: <i>model</i> , <i>date of manufacture</i> (DoM: month/year), <i>serial number</i> (S/N); <i>manufacturer</i> : name, address, website
10.	Compartment cover for the battery and the optional Secure Digital cards.

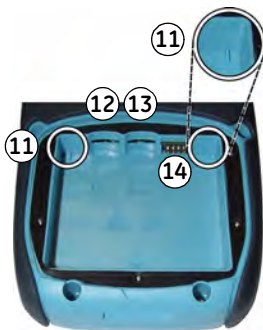



Figure 1-5: Bottom view (cover/battery removed)

11.	Two position guides for the battery. Refer to Section 2.5.2 (Install the battery) .
12.	 Slot for a micro Secure Digital WiFi card *.
13.	 Slot for a micro Secure Digital memory card (maximum: 4GB).
14.	Electrical connections for the battery.

* The micro WiFi card is not yet available but WiFi functions are available with part number: DPI 620 CE WIFI

1.3 The display

This is a LCD with a colour display and a touch-screen. To make a selection, lightly tap on the applicable display area with a finger; see [Section 2.9 \(Display operation\)](#).

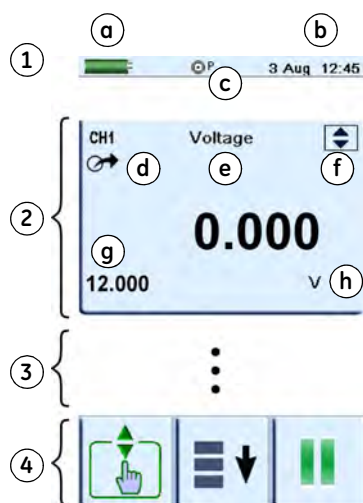











Figure 1-6: Example display

1.	<p>Status bar: This includes:</p> <p>a. Battery indicator b. Date and time</p> <p>c. Indicators for a <i>Pressure</i> connection, a <i>HART</i> protocol resistor, an <i>IDOS</i> connection, <i>Datalog</i> and wireless operation; for example:</p> <p> P : Pressure;  : HART;  : IDOS</p>
2.	<p>CH1: Window for the channel 1 settings and values; see Section 2.10.</p> <p>d. Measure or source indication:</p> <p> : Measure;  : Source</p> <p>e. Function (voltage, current, pressure ...)</p> <p>f. Source process indicator; for example:</p> <p> : Nudge;  : Span check;  : Ramp</p> <p>g. Full scale (FS) range h. Function units</p>
3.	<p>Other windows: The number of windows you see on the display is set by the number of task selections and external modules you are working with (maximum: 6); see Section 2.9.</p>
4.	<p>Tap this button to set up the <i>Task</i>, set up the instrument (<i>Configure</i>) and to access Help (?). see Section 2.10 (Menu sequence). </p>
5.	<p>Tap this button to maximise each of the available windows in sequence; see Section 2.9.4 </p>
6.	<p><i>Pause</i> (⏸) or <i>Play</i> (▶): Tap (⏸) to hold (freeze) all the data on the display. To release the display and continue, tap (▶).</p>

1.4 Accessories

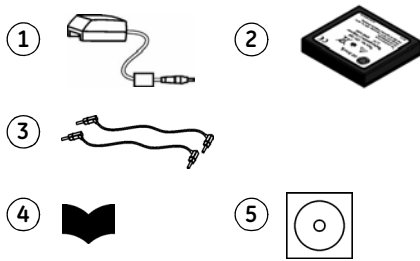

Figure 1-7: Accessories included

1.	IO620-PSU. DC power supply
2.	IO620-BATTERY. Li-Polymer battery
3.	209-539. Set of six electrical test leads
4.	K0454. Safety and quick reference guide
5.	UD-0002. CD with the user manual



6.	IO620-AC. AC probe that attaches to the specified calibrator sockets (see Section 3.2.5) and measures up to 300 VAC.
7.	IO620-CASE-1. Fabric carry case with a belt loop, shoulder strap and a large pocket for accessories. It can hold one DPI 620 calibrator.
8.	IO620-CASE-2. Fabric carry case. It can hold a set of units: one DPI 620 calibrator; one MC 620 module carrier; PM 620 modules and related accessories.
9.	IO620-BATTERY. Spare or replacement Li-Polymer battery.
10.	IO620-CHARGER. External battery charger to charge a battery when it is not in the instrument.
11.	IO620-PSU. Spare DC power supply
12.	IO620-USB-PC. USB mini Type B cable to connect the DPI 620 calibrator to a computer.
13.	IO620-IDOS-USB. Adaptor to connect the DPI 620 to a IDOS universal pressure module.
14.	IO620-USB-RS232. Adaptor to connect the DPI 620 to a RS232 interface.
15.	IO620-FIELD-CAL. Intecal field calibration manager. Use the documenting functions in the calibrator with elements of your Intecal database; set up new device records and procedures; upload Intecal data to your computer database.

16.	Pressure modules (PM 620); refer to the datasheet.
17.	<p>Pneumatic hose kit rated to 400 bar (5800 psi) with "Quick fit" connectors for the test port.</p> <p>IO620-HOSE-P1: 1 metre (\approx 39")</p> <p>IO620-HOSE-P2: 2 metre (\approx 78")</p>
18.	<p>Hydraulic hose kit rated to 1000 bar (15000 psi) with "Quick fit" connectors for the test port.</p> <p>IO620-HOSE-H1: 1 metre (\approx 39")</p> <p>IO620-HOSE-H2: 2 metre (\approx 78")</p>
19.	<p>Pressure adaptor sets designed for the MC 620, PV 62x and the hose kits:</p> <p>IO620-BSP: G1/8, G1/4 male; G1/4, G3/8 and G$\frac{1}{2}$ female</p> <p>IO620-NPT: 1/8NPT, 1/4NPT male, 1/4NPT, 3/8NPT, and 1/2NPT female</p> <p>IO620-MET: M14 x 1.5 and M20 x 1.5 female</p>

Chapter 2: Prepare the instrument

2.1 Introduction

This chapter gives a description of these items:

- the initial checks and procedures
- the available power options
- the battery and related procedures (install and charge)
- the start up procedures
- the menu structure and options
- the *Process* and *Automation* options available for the measure and source ( ) functions

2.2 Initial checks

Before you use the instrument for the first time:

- Make sure that there is no damage to the instrument, and that there are no missing items; see [Figure 1-7](#).
- Remove the plastic film that protects the display. Use the tag () in the top right-hand corner.

2.3 Initial procedures

Before you use the instrument for the first time, complete these procedures:

- Install the battery ([Section 2.5.2](#)). Then re-attach the cover.
- To make sure that the calibration schedule works correctly, set the date and time; see [Section 2.10 \(Menu sequence\)](#).
- Charge the battery ([Section 2.5.3](#))

2.4 Power options

There are three power options:

Lithium-Polymer battery ([Section 2.5](#)): All the instrument functions are available with a charged battery.

5 V DC power supply ([Section 2.6](#)): All the instrument functions are available with or without the battery. It supplies power to the instrument and charges the battery at the same time. It charges the battery when the instrument is on or off.

USB mini Type B connection ([Section 2.7](#)): This charges the battery when the instrument is off and increases the battery life when the instrument is on.

2.5 The battery

⚠ WARNING ⚠

- This instrument uses a Lithium-Polymer (Li-Polymer) battery pack. To prevent an explosion or fire, do not short circuit, do not disassemble, keep it safe from damage. For operating conditions, see [Table 10-1](#).
- To prevent an explosion or fire, use only the GE specified battery, power supply and battery charger.
- To prevent battery leakage or heat generation, only use the battery charger and power supply in the temperature range 0 to 40°C (32 to 104°F). For operating conditions, see [Table 10-1](#).

For a full battery specification, refer to [Table 10-1](#).

2.5.1 Battery condition

When you first get your DPI 620 calibrator, the battery has approximately 60% of full charge. You can use the battery immediately but, for maximum operating time, we recommend you give it a full charge ([Section 2.5.3](#)).

Charge indications



When you set the power on, the battery symbol at the top of the display shows the charge condition in 10% increments.

To get an accurate indication (1% increments), use the *Configuration* menu; see [Section 2.10.2 \(Procedure to see the instrument status\)](#).

2.5.2 Install the battery



Step	Procedure
1.	When the power is off, loosen the five screws (a) and remove the cover (b).
	 If necessary, turn the instrument over and let the discharged battery drop into your hand. If the battery does not hold a charge, discard it safely. Obey all the local health and safety procedures.
2.	Install the new battery correctly until it is flat in the compartment.
3.	Re-attach the cover.

2.5.3 Charge the battery You can charge the battery in the instrument ([Section 2.6](#)) or you can use the optional external battery charger; see [Section 1.4 \(Accessories\)](#).

2.5.4 Charge times

Charge method	Charge time (to full capacity)
DC power supply	≈ 6.5 hours
External battery charger	≈ 6.5 hours
USB mini Type B connector	≈ 13 hours (with a 500 mA supply)

Note: You can use the instrument while the DC charger is charging the battery but this increases the charge time.

2.5.5 Operating time

Operation	Battery duration
Continuous operation (measure)	> 10 hours
Continuous operation (measure and source with loop power on)	> 6 hours

These are typical operating times for a new, fully charged Li-polymer battery pack with these settings:

- *Backlight Intensity* set to 80% (Default: 80%)
- *Backlight Timeout* set to 2 hours (Default: 2 minutes)

Power save options To get the best battery duration, set a low value for the *Backlight Intensity* (40%) and a short *Timeout*; see [Section 2.10.1 \(Procedure to set the basic operations:\)](#)

2.6 The DC power supply

⚠ WARNING ⚠

- To prevent an explosion or fire, use only the GE specified battery, power supply and battery charger.
- To prevent battery leakage or heat generation, only use the battery charger and power supply in the temperature range 0 to 40°C (32 to 104°F). For operating conditions, see [Table 10-1](#).



Status bar:
Charging symbols

This unit supplies power to the instrument and charges the battery (if it is installed). All the instrument functions are available with or without the battery.

If there is a battery, internal safety circuits control the charge cycle. If you are using the instrument, this increases the time to charge the battery.

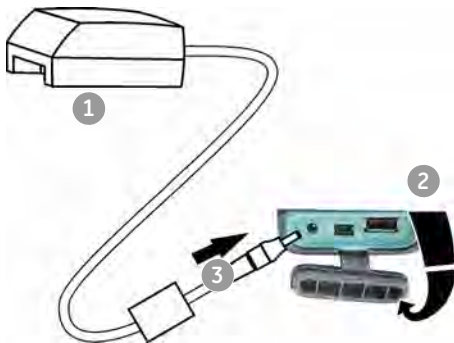

Step	Procedure
1.	Attach the applicable socket adaptor to the DC power supply.
2.	On the right-hand side of the instrument (Figure 1-3), use the rubber recess to pull down the cover for the connections.
3.	Push the power supply connector into the 5 V DC input socket and set the power on.

2.7 The USB power supply

You can use the optional mini Type B cable to supply power to the instrument.

This charges the battery when the instrument is off and increases the battery life when the instrument is on.

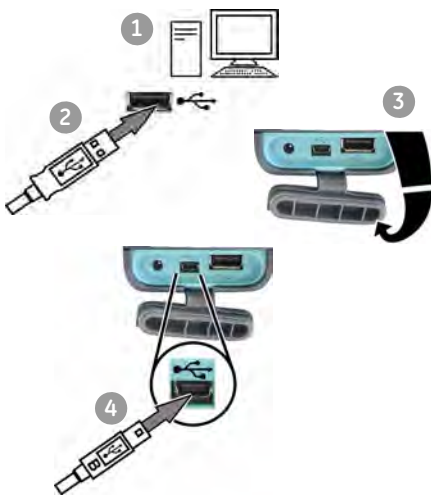

Step	Procedure
1.	Start the computer.
2.	Push the Type A end of the USB cable into a USB socket on your computer.
3.	On the right-hand side of the instrument (Figure 1-3), use the rubber recess to pull down the cover for the connections.
4.	Push the mini Type B end of the USB cable into the USB socket on the instrument.

2.8 Power on or off



To set the instrument power on, press and hold this button down until the display comes on (\approx 2 seconds). During the power on sequence, the instrument shows a timer and then shows the applicable data.

To set the instrument power off, press and release this button again. When the power is off, the last set of configuration options stays in memory.

2.9 Display operation



This instrument has a touch-screen. To make a selection, lightly tap on the applicable display area (window, button, option) with a finger.

Caution: To prevent damage to the display, do not use sharp objects on the touch-screen.

The number of windows you see on the display is set by the number of task selections and external modules you are working with (maximum: 6); see [Section 2.10.3 \(Procedures to make Task selections\)](#).

2.9.1 Change items in a list

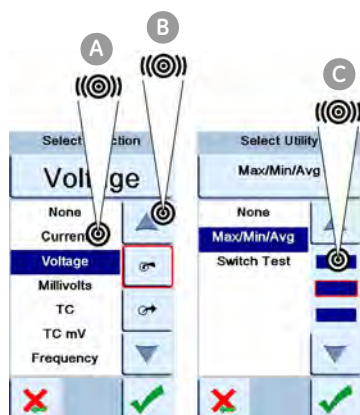

To change an item in a list, you have these options:

- tap on the item you want to use **A**
- tap on the ▲ or ▼ button **B**
- tap on one of the horizontal bars beside the list **C** (if applicable)

 **Accept:** To accept the selection and go back to the previous display, tap this button. If necessary, tap this button on all subsequent displays until you get back to the start.

 **Cancel:** To cancel the selection and go back to the previous display, tap this button

2.9.2 Change numeric values



There are numeric keypad displays for these items:

- dates and times
- setpoint values
- source *Automation* processes (*Nudge*, *Span Check*, ...)
- calibration and other processes

Tap in the necessary value on the keypad. If applicable, the keypad includes the buttons for +/- and decimal point.



Backspace: To go back one character, tap this button. If it is not a date or time, it deletes the character.



Accept: To accept the specified value and go back to the previous display, tap this button.



Cancel: To cancel the specified value and go back to the previous display, tap this button.

2.9.3 Enter text



There are alphanumeric keypad displays for these items:

- Captions; see [Section 2.10.4](#) (maximum: 15 characters; all characters permitted)
- Filenames (maximum: 10 characters; no special characters)

1. Tap in the applicable characters.
2. To accept the data and go back to the previous display, tap on the completed text in the data entry box.



Next keypad: To use characters on the next keypad (upper case > lower case > numeric), tap this button.



Delete: To delete the last character in the data entry box, tap this button.



Escape: If there are no characters in the data entry box, the *Esc* button replaces the *Del* button. To leave the keypad and go back to the previous display, tap on the *Esc* button.

2.9.4 Maximise/minimise a window

You can have up to 6 functions on the display. To set a *Process* (measure operations), an *Automation* option (source operations), or other *Settings* you must maximise the applicable function:

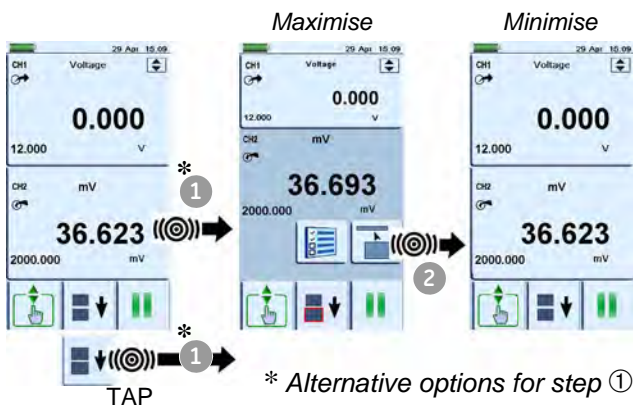

Processes (measure operations)



Automation (source operations)



2.10 Menu sequence

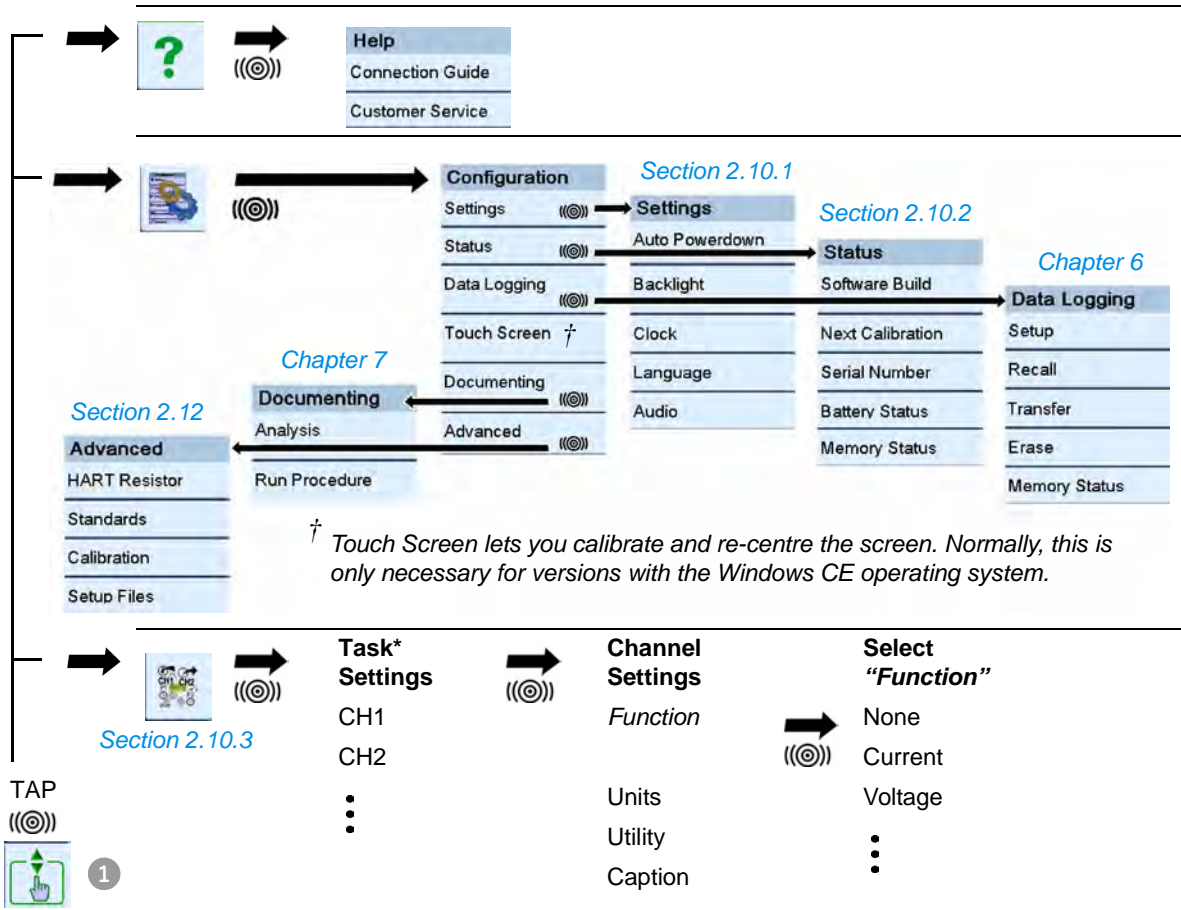

* A channel can only have one function at a time.

2.10.1 Procedure to set the basic operations:

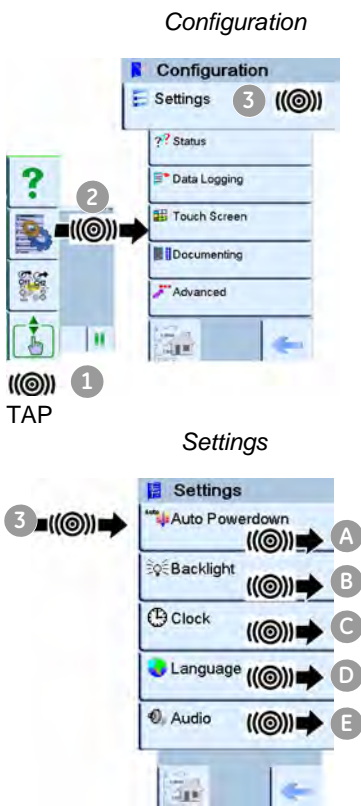

Description	
	<p>Sets the power off automatically after the specified <i>Timeout</i> period. To save the battery power, set this to <i>On</i>.</p> <p>Status: On or Off</p> <p>Timeout: 00:02:00 to 01:00:00 hours:minutes:seconds (hh:mm:ss)</p>
	<p>Sets the backlight. Low values save battery power; see Section 2.5.5 (Operating time).</p> <p>Timeout: 00:02:00 to 02:00:00 hours:minutes:seconds (hh:mm:ss)</p> <p>Intensity: 20, 40, 60, 80, 100%</p>
	<p>Sets the date and time. The calibration function uses this to give calibration messages.</p> <p>Date: day/month/year (dd/mm/yy) OR month/day/year (mm/dd/yy). The format is factory configured.</p> <p>Time: 24 hour; hours:minutes:seconds (hh:mm:ss)</p>
	<p>Sets the language.</p> <p>Selected: English (Other languages to be released).</p>
	<p>Sets the volume of the tones and alarms.</p> <p>Volume: Mute, Low, Medium, High.</p>

2.10.2 Procedure to see the instrument status

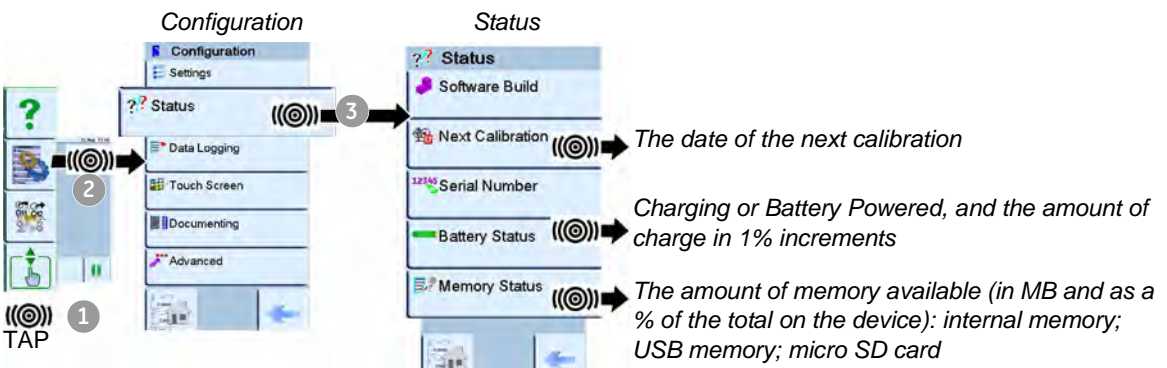

2.10.3 Procedures to make Task selections

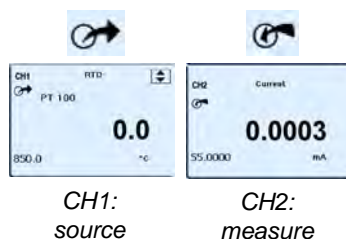

When you first use the calibrator, there are default measure  and source  functions on the display:





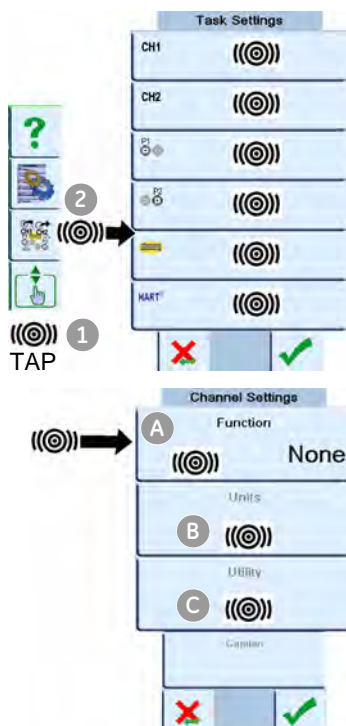















- CH1 settings: RTD source, RTD type is PT100, scale is °C; Automation is *Nudge*; see [Chapter 3](#).
- CH2 settings: Current measure, see [Chapter 3](#).

Procedure Overview Use the *Task* menu to complete these procedures:



- Set the calibrator functions you want to use on the display: item **A** ; see [Section 2.10.4](#).

a. CH1: Channel 1 electrical function: You can choose one option:

None		Resistance			
Current			RTD		
Voltage			CJ		
Millivolts			AC Volts		
TC (°C/°F)			AC mV		
TC (mV)			AC Probe		
Frequency			Observed*		

b. CH2: Channel 2 electrical function: You can choose one option:

None		Voltage		
Current			Millivolts	
Current (24V)			Observed*	

- c. * Pressure function (P1): for the PV 62x pressure stations, refer to user manual - K0457; for the MC 620 module carrier, see [Chapter 4](#).
- d. * Pressure function (P2): the MC 620 module carrier can use P1 and/or P2; see [Chapter 4](#).
- e. * IDOS function: Universal pressure module; see [Chapter 3](#).
- f. HART function: HART device communications; see [Chapter 8](#)

- If applicable, change the *Units* for the function: item **B** ; see [Section 2.10.5](#)

Note: * Observed (Only available as a source option). Use this option to make a manual record of the readings on another instrument; see [Section 2.11.3](#)

Continued

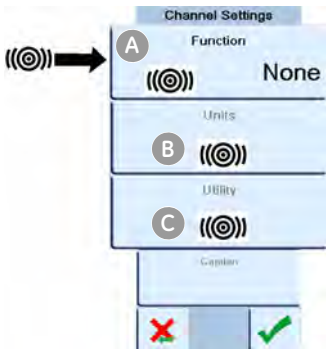

- If applicable, set a *Utility* for the function: item **C**
 - a. *Max/Min/Avg*; see [Section 2.10.6](#)
 - b. *Switch Test*. CH1, P1, P2 and IDOS functions use the CH2 switch connections; CH2 functions use the CH1 switch connections. See [Chapter 3](#)
 - c. *Leak Test (Pressure options only)*; see [Chapter 4](#)

Note: If you make the connections for a switch on CH1 or CH2, you cannot set another function on that channel.

2.10.4 Set a function

This example shows the sequence to set the Channel 1 (CH1) function. It is a similar procedure for other functions.

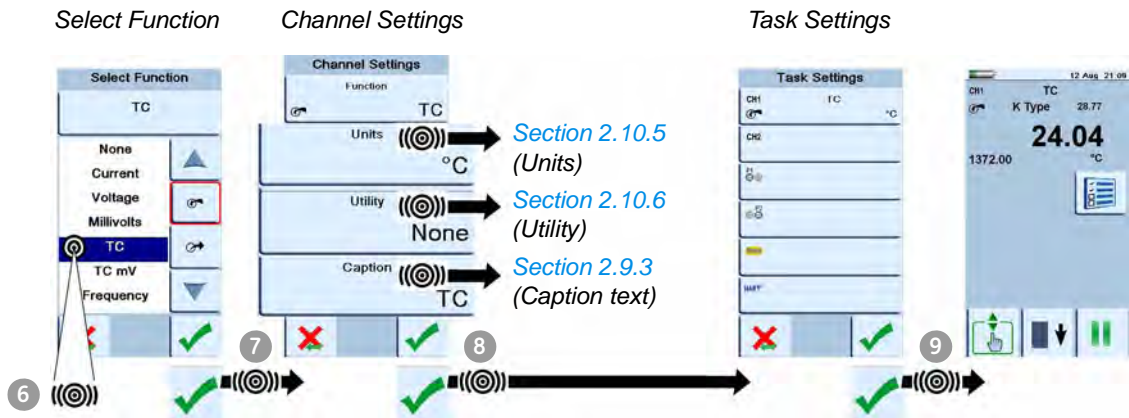
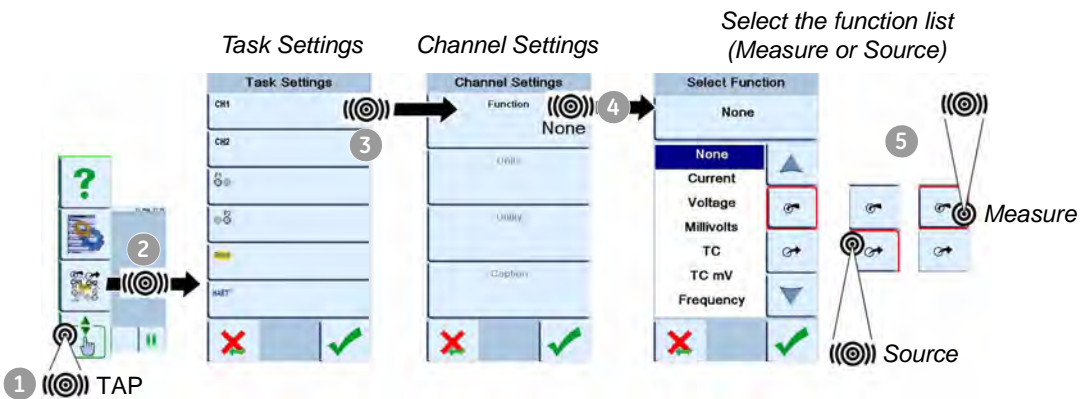

2.10.5 Set the units

If a function has alternative units, you can set another unit. If there are no alternatives, the area is shown grey.

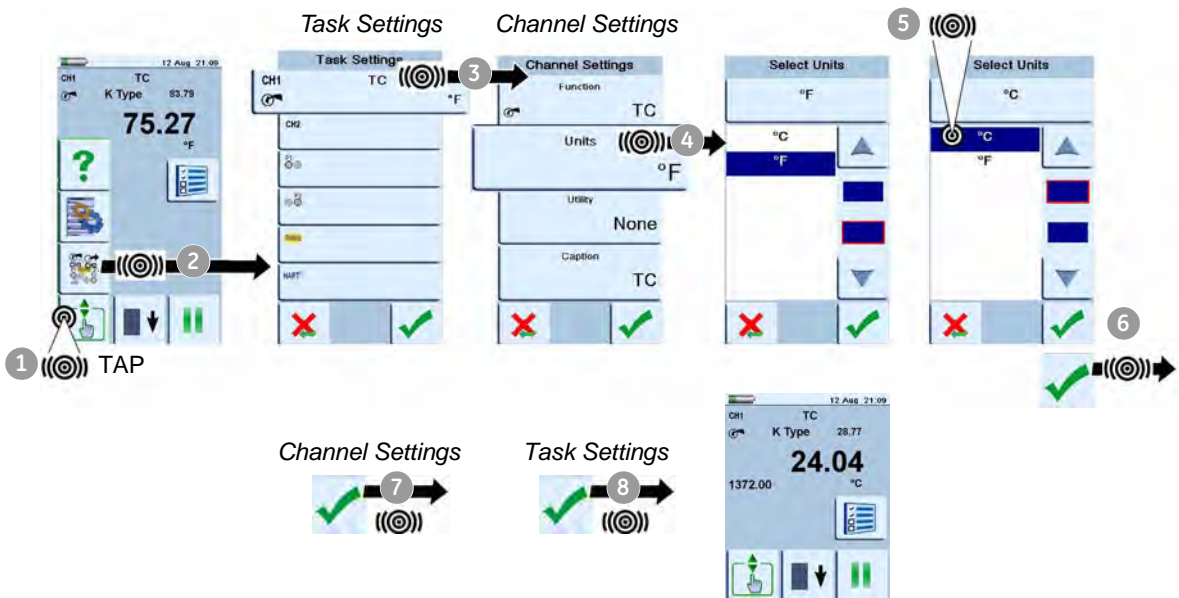

2.10.6 Set up a utility: Maximum/Minimum/Average example

This example shows the sequence to set the *Max/Min/Avg* utility. You can use the same procedure for these options:

- *Switch Test*; see [Chapter 3](#)
- *Leak Test (pressure options only)*; see [Chapter 4](#)

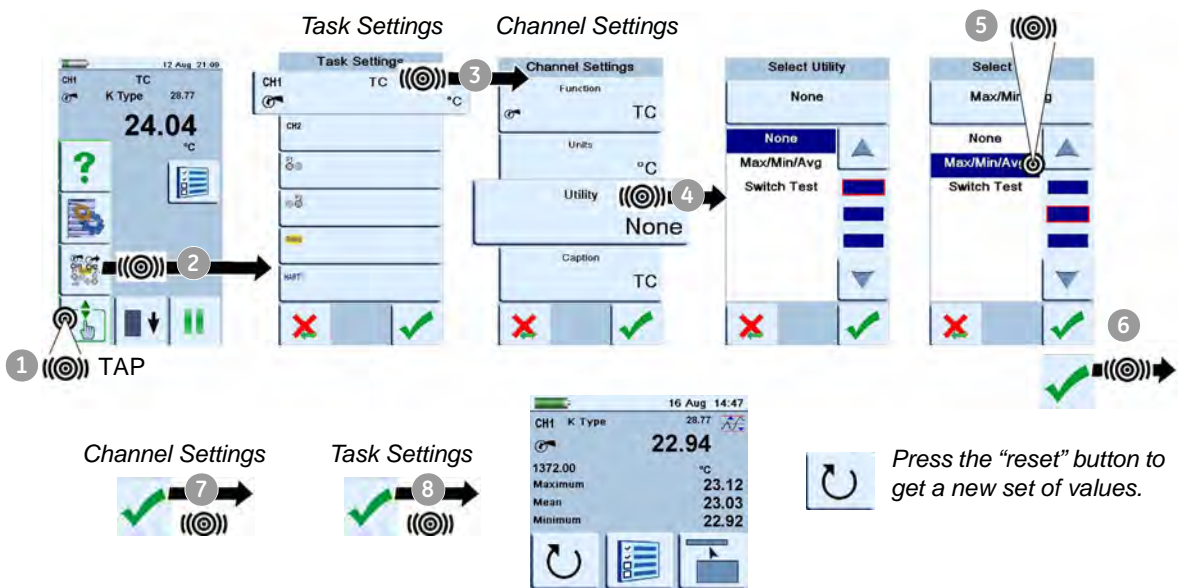

2.11 Measure and source operations

When you have set the measure and source functions that you want to see on the display (see [Section 2.10.3](#)), you can complete these procedures:

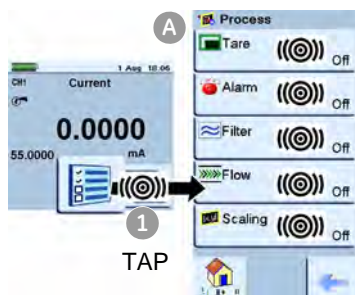

- If necessary, change the *Process* for the CH1 and/or CH2 measure functions: item **A**

This includes: *Tare, Alarm, Filter, Flow, Scaling*; see [Section 2.11.1](#)

There are more optional *Settings* for the *TC, Frequency, and RTD* functions; see [Chapter 3](#).

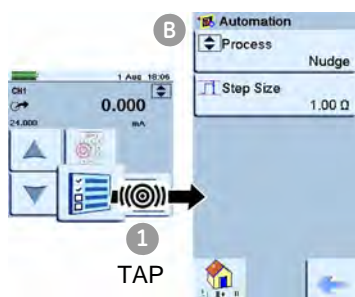

- If necessary, change the *Automation* options for the CH1 and/or CH2 source functions: item **B**

This includes: *Nudge, Span Check, Percent Step, Defined Step, Ramp*; see [Section 2.11.2](#)

There are more optional *Source Settings* for the *TC, Frequency, and RTD* functions; see [Chapter 3](#).

There are other *Settings* for *Observed* functions; see [Section 2.11.3](#)

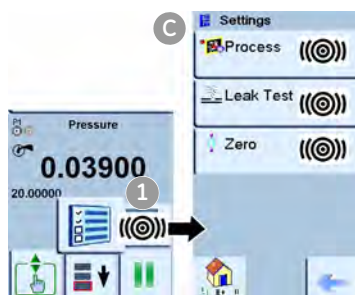

- If necessary, change the *Settings* for the pressure function: item **C**

a. *Process (Tare, Alarm, Filter, Flow, Scaling)*; see [Section 2.11.1](#)

b. *Leak Test* (Only when the function is set up with this *Utility - Section 2.10.6*); for operation, see [Chapter 4](#).

c. *Zero*; see [Chapter 4](#)

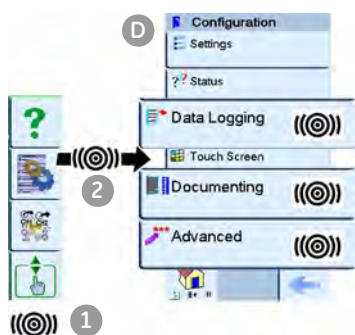

- If necessary, change the *Configuration*: item **D**

This includes: *Data Logging (Chapter 6), Documenting (Chapter 7), and Advanced options (Section 2.12)*.

- When all the software selections are complete, make the applicable connections (electrical and/or pressure).

Examples:

a. Electrical and IDOS operations ([Chapter 3](#));

b. Pressure operations with the MC 620 module carrier ([Chapter 4](#))

c. Pressure operations with a PV 62x pressure station (refer to the user manual - K0457)

2.11.1 Set the Process options (measure )

Note: Section 2.9 (Display operation) shows how to set and change the values on the display.

 **Tare** Use *Tare* to set a temporary value for zero. This makes an adjustment to all subsequent readings on the display.

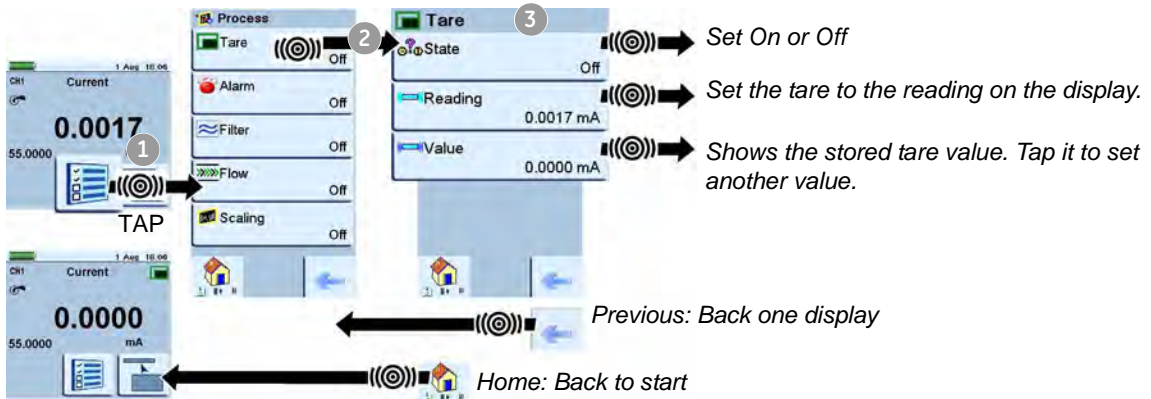

The diagram illustrates the steps to set the Tare function. It shows three sequential screens:

- Screen 1:** The main display shows a current reading of 0.0017 mA. A 'TAP' icon is overlaid on the reading, with a circled '1' next to it.
- Screen 2:** The 'Process' menu is open, and the 'Tare' option is selected. A circled '2' is next to the 'Tare' icon. The 'Tare' status is currently 'Off'.
- Screen 3:** The 'Tare' settings menu is shown. A circled '3' is next to the 'Tare' icon. The 'State' is 'Off'. The 'Reading' is set to 0.0017 mA, and the 'Value' is set to 0.0000 mA.

Navigation arrows and labels are provided:

- An arrow from the 'Tare' icon in Screen 2 points to the text: "Set On or Off".
- An arrow from the 'Reading' field in Screen 3 points to the text: "Set the tare to the reading on the display."
- An arrow from the 'Value' field in Screen 3 points to the text: "Shows the stored tare value. Tap it to set another value."
- An arrow from the 'Previous' button in Screen 3 points to the text: "Previous: Back one display".
- An arrow from the 'Home' button in Screen 3 points to the text: "Home: Back to start".

 **Alarm:** The alarm includes a “beep” sound if Audio is set (Section 2.10.1).

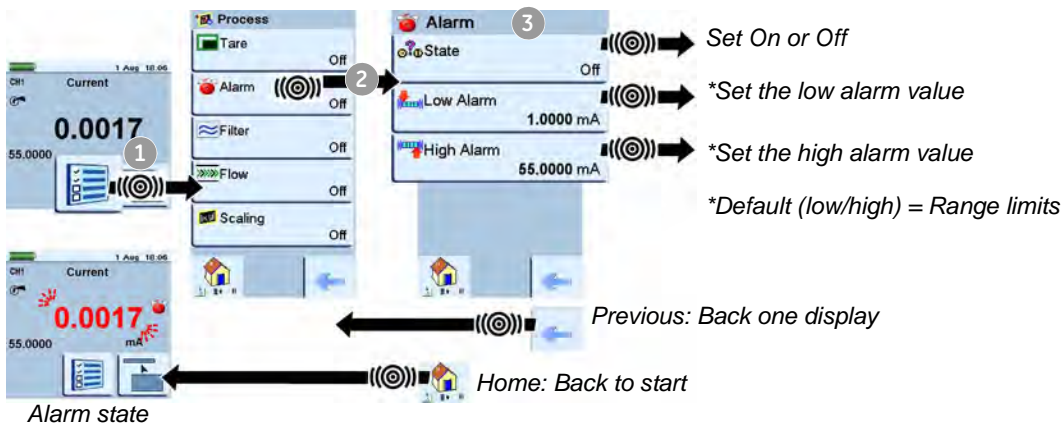

The diagram illustrates the steps to set the Alarm function. It shows three sequential screens:

- Screen 1:** The main display shows a current reading of 0.0017 mA. A red alarm icon is overlaid on the reading, with a circled '1' next to it.
- Screen 2:** The 'Process' menu is open, and the 'Alarm' option is selected. A circled '2' is next to the 'Alarm' icon. The 'Alarm' status is currently 'Off'.
- Screen 3:** The 'Alarm' settings menu is shown. A circled '3' is next to the 'Alarm' icon. The 'State' is 'Off'. The 'Low Alarm' is set to 1.0000 mA, and the 'High Alarm' is set to 55.0000 mA.

Navigation arrows and labels are provided:

- An arrow from the 'Alarm' icon in Screen 2 points to the text: "Set On or Off".
- An arrow from the 'Low Alarm' field in Screen 3 points to the text: "*Set the low alarm value".
- An arrow from the 'High Alarm' field in Screen 3 points to the text: "*Set the high alarm value".
- A note below the High Alarm field states: "*Default (low/high) = Range limits".
- An arrow from the 'Previous' button in Screen 3 points to the text: "Previous: Back one display".
- An arrow from the 'Home' button in Screen 3 points to the text: "Home: Back to start".

The label "Alarm state" is positioned at the bottom left of the diagram.

 **Filter:** You can set the *Band* and the *Time Constant* for the low pass filter:

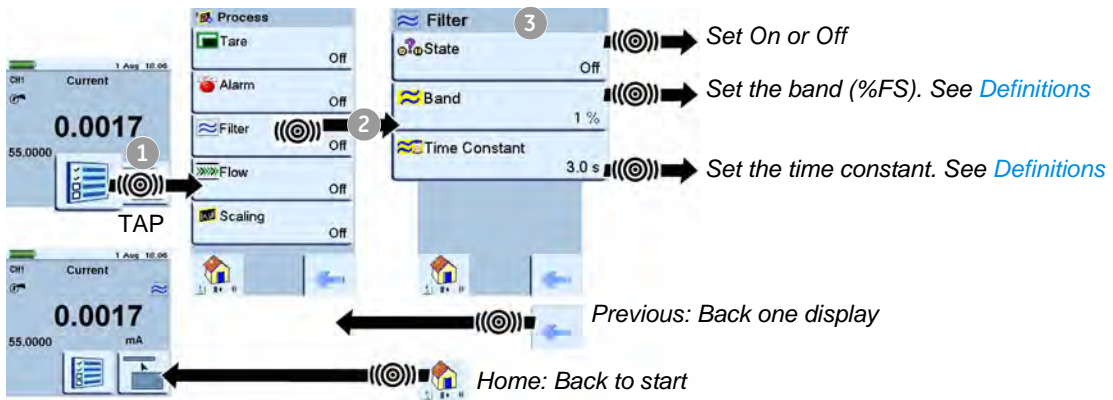

Definitions

Band: The filter compares each new value with the previous value. If the new value is outside the band, it is not filtered.

Time Constant: This sets the cut-off frequency for the filter. Higher value (in seconds) = more filtering.

 **Flow:** (Square root function)

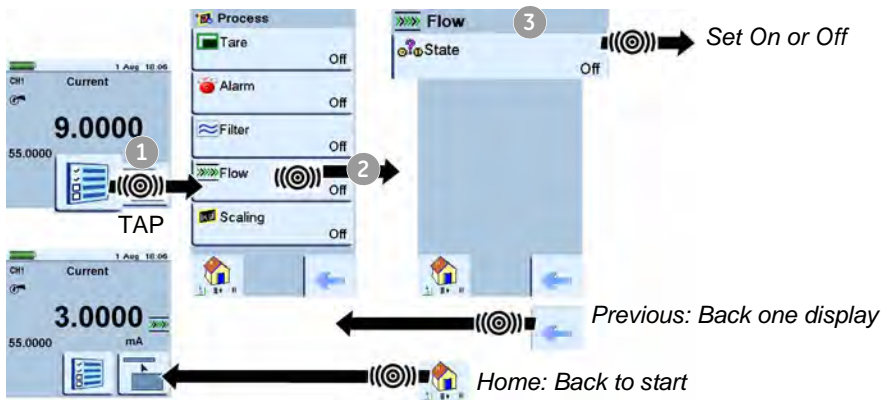

Scaling:

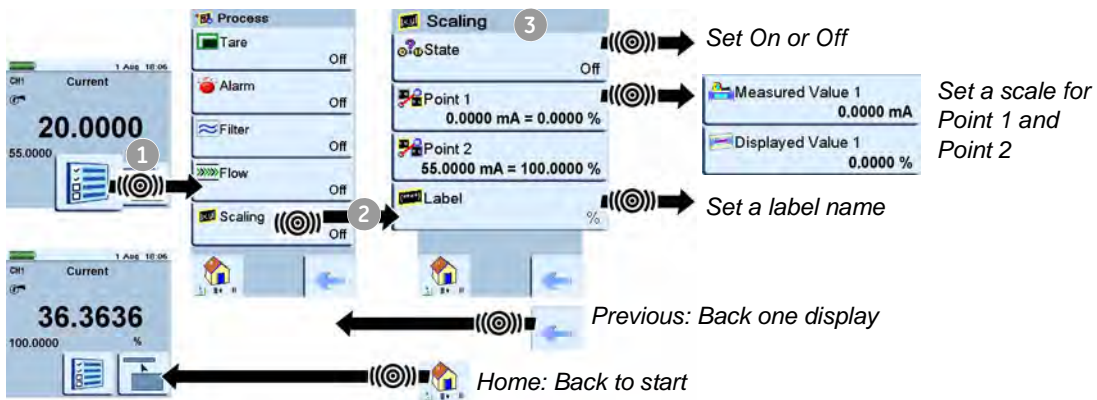

2.11.2 Set the Automation options (source)

Note: [Section 2.9 \(Display operation\)](#) shows how to set and change the values on the display.

Nudge

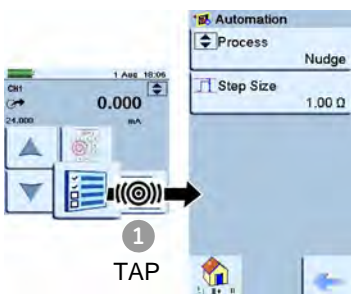

Description
Process: Nudge; Values to set: Step Size

- Use these buttons to increase or decrease the output value. Increments = Step size.
- Use this button (Setpoint) to set the output value.

Span Check

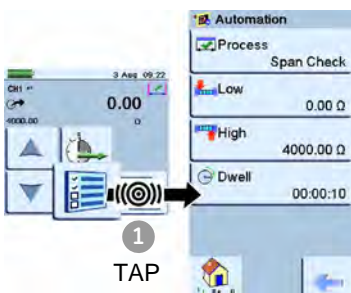

Description
Process: Span Check; Values to set: Low, High, Dwell

- Use these buttons to change the value manually from High to Low.
- Use the start and stop buttons to change the value automatically from High to Low. Dwell sets the period between each change. The cycle repeats automatically.

 **Percent Step**

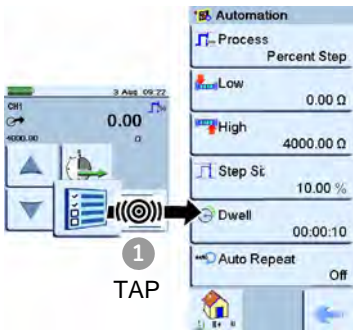

Description

Process: Percent Step;

Values to set: Low, High, Step Size (%FS), Dwell, Auto Repeat (On/Off)



Use these buttons to change the value manually by the specified *Step Size*.



Use the start and stop buttons to change the value automatically by the specified *Step Size*.

Dwell sets the period between each change.

 **Defined Step**

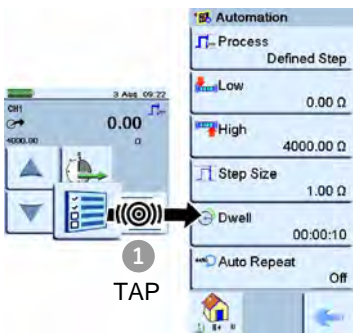

Description

Process: Defined Step;

Values to set: Low, High, Step Size, Dwell, Auto Repeat (On/Off)



Use these buttons to change the value manually by the specified *Step Size*.



Use the start and stop buttons to change the value automatically by the specified *Step Size*.

Dwell sets the period between each change.

 **Ramp**

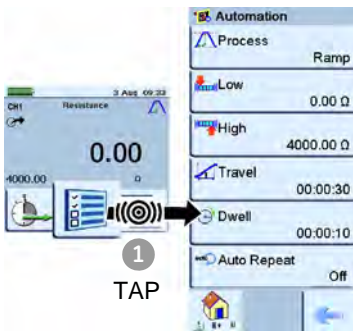

Description

Process: Ramp;

Values to set: Low, High, Travel, Dwell, Auto Repeat (On/Off)



Use the start and stop buttons for this process. *Travel* sets the duration of the *Ramp*.

Dwell sets the period between each change in direction.

2.11.3 Set the Observed settings (source )

The *Observed* function is available as a *Source* on five of the task selections: CH1, CH2, P1, P2, and IDOS. To set the *Observed* function, see [Section 2.10.4](#).

You can use the *Observed* function to make a manual record of the readings you can see on another instrument. For example, you can make a permanent record of the readings with *Data Logging* (Chapter 6).

Settings These settings are available:

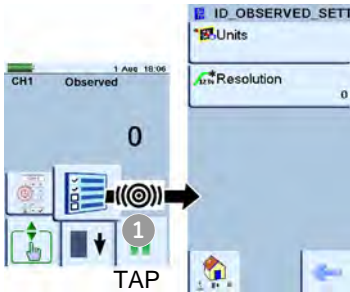

Description
<p><i>Values to set:</i></p> <p>Units (enter a name for the units)</p> <p>Resolution (Set one of the 7 options: 1.0 to 0.000001)</p>



Use this button (Setpoint) to set the values you see on the other instrument.

2.12 The Advanced menu options

The Advanced menu lets you set or use these options:

- HART resistor
- Standards
- Calibration
- Setup Files

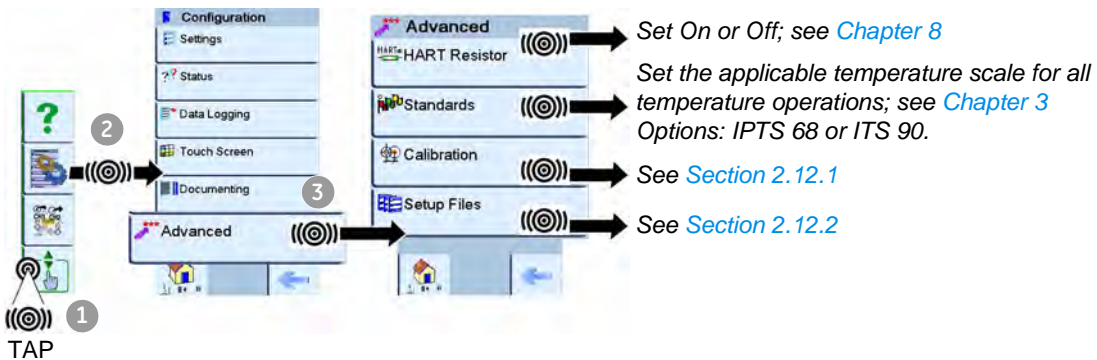

2.12.1 Advanced: Calibration options

There are two calibration menus you can use:

Menu to calibrate the DPI 620

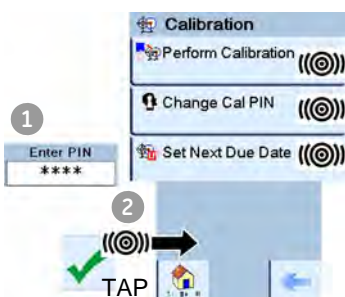

1. Enter the calibration PIN: 4321
2. Tap the “Accept” button. You can then continue with these operations:
 - Calibrate the different measure and source channels on the DPI 620 calibrator.

Contact us at: www.gesensinginspection.com

- Change the calibration PIN. You must confirm the new PIN.

- Set the next calibration date and/or set the *Notification* option. If *Notification* is *On* and your calibration is overdue, you get a “Calibration due ... ” message at the end of the power on sequence.

Menu to upgrade the DPI 620 software and firmware

To use most up to date software and firmware on your DPI 620 calibrator, visit our website:

www.gesensinginspection.com

Follow the website instructions to download the files onto a USB flash memory drive. You can then use this menu to upgrade your calibrator.

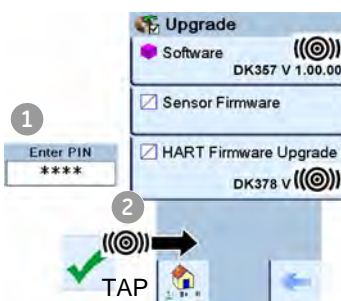

1. Enter the calibration PIN: 5487
2. Tap the “Accept” button. You can then continue with one of these operations:
 - Upgrade the software. To complete this operation, put the USB flash memory drive in the USB type A connector (Figure 1-3) and follow the on-screen instructions.
 - Upgrade the sensor firmware (PM 620). To complete this operation, put the USB flash memory drive in the USB type A connector (Figure 1-3) and follow the on-screen instructions.
 - Upgrade the HART Firmware. To complete this operation, put the USB flash memory drive in the USB type A connector (Figure 1-3) and follow the on-screen instructions.

Note: If you make a mistake and there are no files to upload, follow the on-screen instructions and complete the procedure.

When an upgrade completes normally, the initial operation of the touch screen is slower (a period of approximately 30 seconds).

To make sure the upgrade completed correctly, use the *Status* menu (Configuration > Status > Software Build); see [Section 2.10.2](#).

2.12.2 Advanced Setup options



Use this menu to save and recall personal settings, instrument calibration settings and other standard instrument operations.

Save: When you have set up the functions you want to see on the display ([Section 2.10.3](#)) and all the measure and source operations ([Section 2.11](#)), save your settings to a file.

Recall: When you want to use the specified settings again, select the applicable filename from the list.

Erase One File: This deletes one file from the list. You must confirm that you want to delete the file.

Memory Status: The amount of memory available (in MB and as a % of the total on the device): internal memory; USB memory; micro SD card

2.13 The Help menu



The Help menu includes electrical connection diagrams to help you set up and use the electrical functions on channel 1 (CH1), Channel 2 (CH2).

Chapter 3: Electrical and IDOS operations

3.1 Introduction

This section gives examples of how to connect and use the instrument for these operations:



- to measure and source electrical values
- to measure the pressure with an IDOS module

Before you start:

- Read and understand the “[Safety](#)” section.
- Do not use a damaged instrument.

Note: Use only original parts supplied by the manufacturer.

3.2 Measure and source operations

When you first use the calibrator, there are default measure  and source  functions on the display; see [Section 2.10.3](#).

3.2.1 Procedure overview

To use the calibrator, complete these procedures:

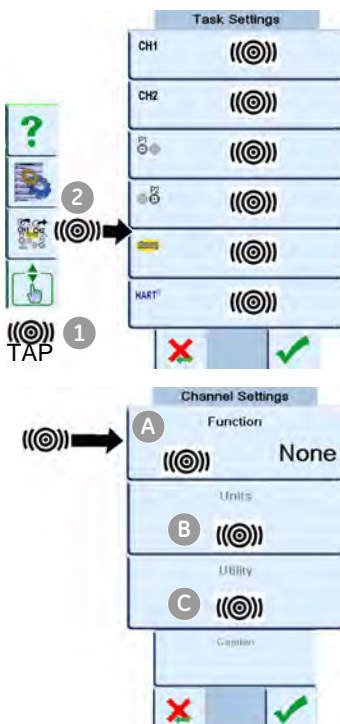

- Set the calibrator functions you want to use on the display: item **A** ; see [Section 2.10.3](#). This includes:
 - a. CH1: Channel 1 electrical function (measure or source)
 - b. CH2: Channel 2 electrical function (measure or source)
 - c. Pressure function (P1 and/or P2): for the MC 620 module carrier, see [Chapter 4](#); for the PV 62x pressure stations (P1 only), refer to user manual - K0457
 - d. IDOS function: to measure pressure with an IDOS universal pressure module (UPM), see [Section 3.3](#)
 - e. other functions (maximum: 6 functions)
- If necessary, change the *Units* for the function: item **B** ; see [Section 2.10.5](#)
- If necessary, set a *Utility* for the function: item **C** ; see [Section 2.10.6](#)
 - a. *Max/Min/Avg*
 - b. *Switch Test*
 - c. *Leak Test* (pressure options only)

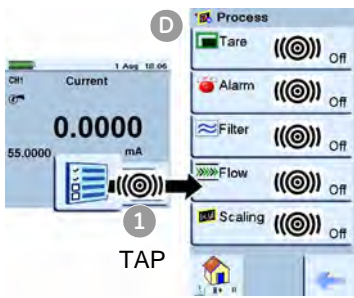

- If necessary, change the *Process* for the CH1 and/or CH2 measure functions: item **D**

This includes: *Tare, Alarm, Filter, Flow, Scaling*; see [Section 2.11.1](#).

There are more optional *Settings* for the *TC, Frequency, and RTD* functions.

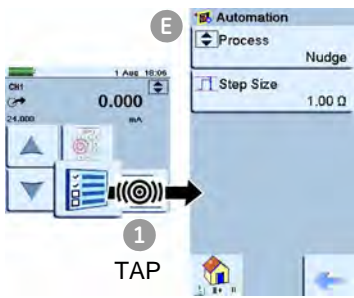

- If necessary, change the *Automation* options for the CH1 and/or CH2 source functions: item **E**

This includes: *Nudge, Span Check, Percent Step, Defined Step, Ramp*; see [Section 2.11.2](#)

There are more optional *Source Settings* for the *TC, Frequency, and RTD* functions.

There are other *Settings* for *Observed* functions; see [Section 2.11.3](#).

- When all the software selections are complete, make the applicable electrical connections.

3.2.2 Example procedure: Measure or source current

These examples (A and B) show Channel 1 (CH1) set up to measure or source a current with external loop power.

Note: If you use the Channel 2 (CH2) connectors, you can use Channel 2 to measure or source these ranges with internal or external loop power (internal loop power = 24 V).

- A**
 Measure current on channel 1 (CH1)
 Range: ±55 mA

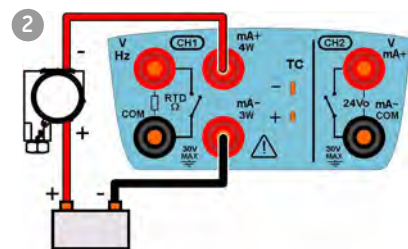
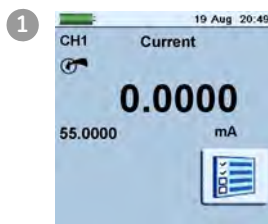

Maximum: 30V

- B**
 Source current on channel 1 (CH1)
 Range: 0 to 24 mA
Automation: Nudge
 ([Section 2.11.2](#))

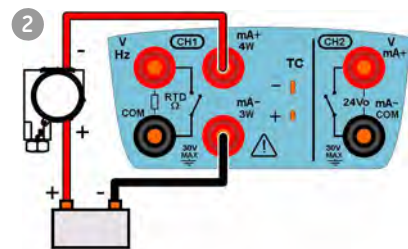
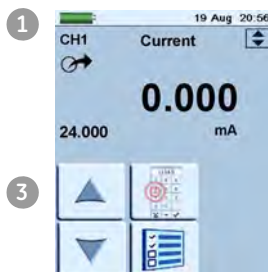

Maximum: 30V

1. Set the applicable software options; see [Section 3.2.1 \(Procedure overview\)](#).
2. Complete the electrical connections and continue with the measure or source operation.
3. Source only (*Automation*): Set the applicable output value; see [Section 2.11.2](#).

3.2.3 Example procedure: Measure DC voltage

These examples (A and B) show Channel 1 (CH1) set up to measure a DC voltage.

Note: If you use the Channel 2 (CH2) connectors, you can use Channel 2 (CH2) to measure these ranges.

A

Measure DC volts on channel 1 (CH1)

Range: ± 30 V (DC)

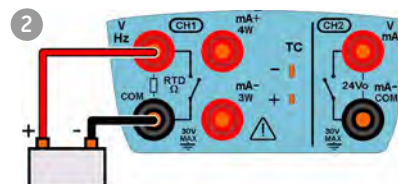
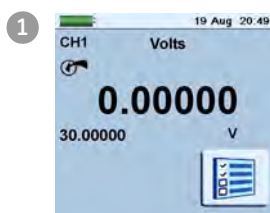

B

Measure DC millivolts on channel 1 (CH1)

Range: ± 2000 mV (DC)



1. Set the applicable software options; see [Section 3.2.1 \(Procedure overview\)](#).
2. Complete the electrical connections and continue with the measure operation.

3.2.4 Example procedure: Measure AC voltage (CH1), 0 to 20 Vrms only

⚠ WARNING ⚠

To prevent electrical shocks, use only the GE specified AC probe (Part: IO620-AC) to measure AC voltages that are more than 20 Vrms (maximum: 300 Vrms). Attach it to the specified connections only. See [Section 3.2.5](#).

These examples (A and B) show Channel 1 (CH1) set up to measure an AC voltage (0 to 20Vrms only).

- A**
 Measure AC volts on channel 1 (CH1)
 Range: 0 to 20 V(rms)

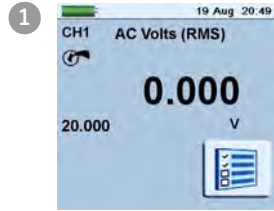

Maximum: 0 to 20 Vrms

- B**
 Measure AC millivolts on channel 1 (CH1)
 Range: 0 to 2000 mV(rms)

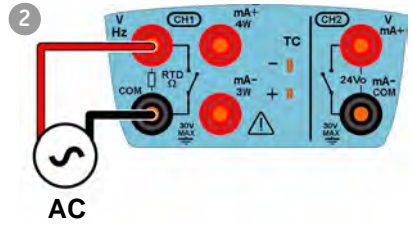
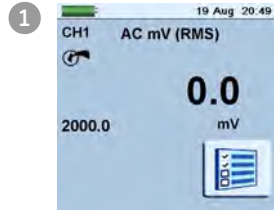

1. Set the applicable software options; see [Section 3.2.1 \(Procedure overview\)](#).
2. Complete the electrical connections and continue with the measure operation.

3.2.5 Example procedure: Measure AC voltage (CH1) with the AC probe

⚠ WARNING ⚠

To prevent electrical shocks, use only the GE specified AC probe (Part: IO620-AC) to measure AC voltages that are more than 20 Vrms (maximum: 300 Vrms). Attach it to the specified connections only.

This example shows Channel 1 (CH1) set up to measure an AC voltage with the AC probe (maximum: 300 Vrms).

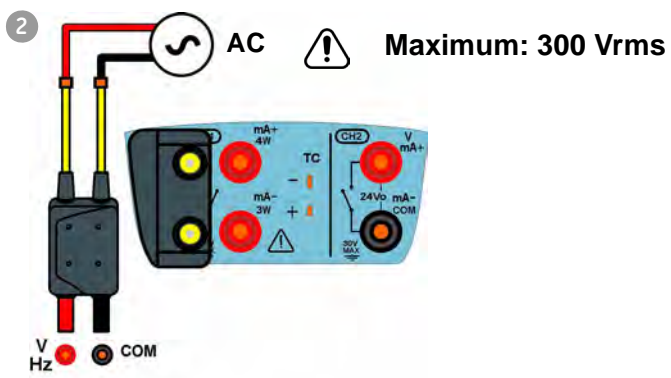
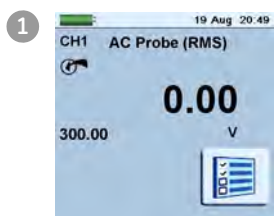

1. Set the applicable software options for the AC Probe; see [Section 3.2.1 \(Procedure overview\)](#).
2. Complete the electrical connections.
Red: V/Hz connector; Black: COM connector
 Then continue with the measure operation.

3.2.6 Example procedure: Source DC voltage (CH1)

These examples (A and B) show Channel 1 (CH1) set up to source a DC voltage.

- A**
- Source DC volts on channel 1 (CH1)
 Range: 0 to 12 V (DC)
 Automation: Nudge
 (Section 2.11.2)

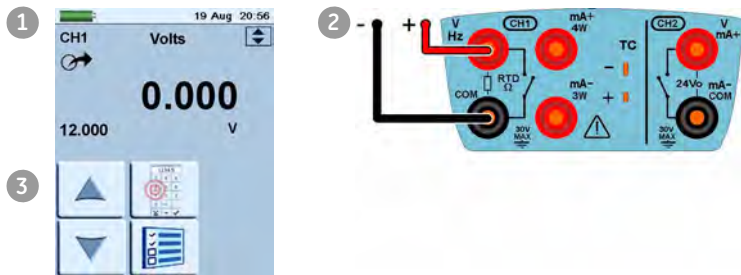

- B**
- Source DC millivolts on channel 1 (CH1)
 Range: 0 to 2000 mV (DC)
 Automation: Nudge
 (Section 2.11.2)

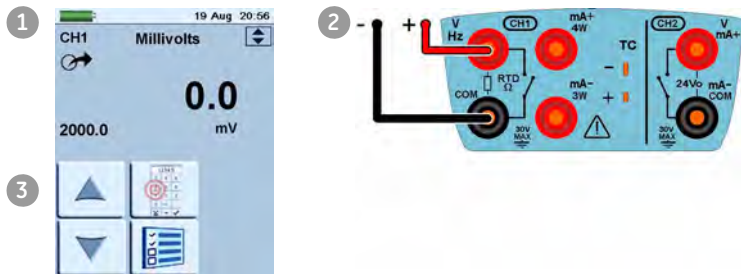

1. Set the applicable software options; see Section 3.2.1 (Procedure overview).
2. Complete the electrical connections.
3. To continue, set the applicable output value; see Section 2.11.2.

3.2.7 Example procedure: Measure or source current with internal 24V loop power

These examples (A and B) show Channel 2 (CH2) set up to measure or source a current with internal loop power (24 V).

- A**
- Measure current on channel 2 (CH2) + internal loop power (24 V)
 Range: ±55 mA

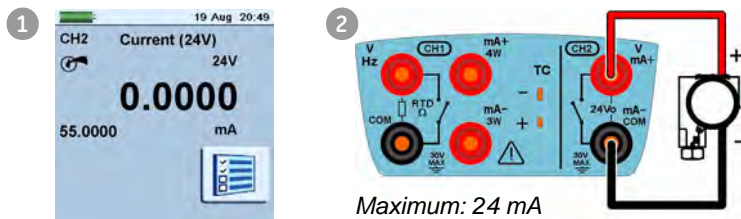

- B**
- Source current on channel 2 (CH2) + internal loop power (24 V)
 Range: 0 to 24 mA
 Automation: Nudge
 (Section 2.11.2)

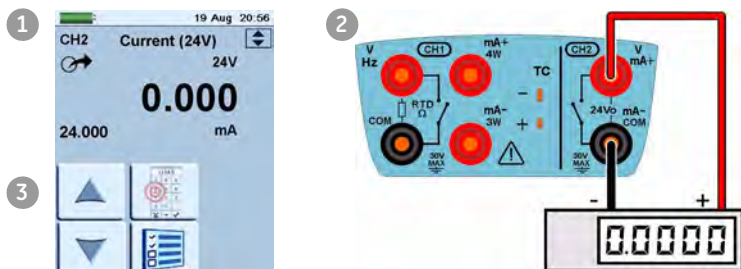

1. Set the applicable software options; see [Section 3.2.1 \(Procedure overview\)](#).
2. Complete the electrical connections and continue with the measure or source operation.
3. Source only (*Automation*): Set the applicable output value; see [Section 2.11.2](#).

3.2.8 Example procedure: Measure or source frequency signals

These examples (A and B) show Channel 1 (CH1) set up to measure or source a frequency. This includes Hz, kHz and counts (cpm or cph).

The selection of units sets the available range, for example:

Hz = 0 to 1000 Hz kHz = 0 to 50 kHz

- A**
- Measure frequency on channel 1 (CH1)
 Range: 0 to 50 kHz
 Trigger level: 2.5 V

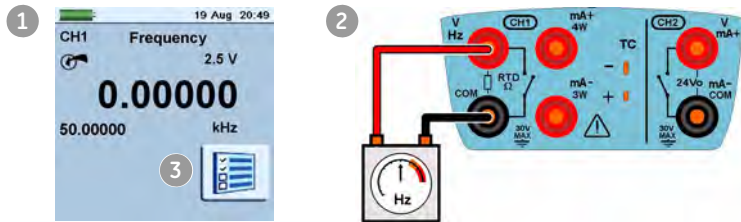

- B**
- Source frequency on channel 1 (CH1)
 Range: 0 to 50 kHz
 Waveform: Triangle
 Amplitude: 12.0 V
Automation: Nudge ([Section 2.11.2](#))

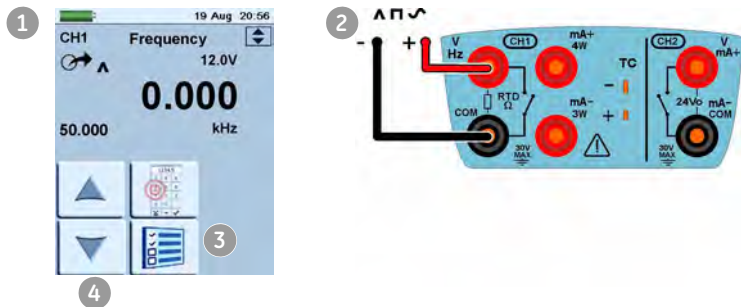

- Example A**
1. Set the applicable software options; see [Section 3.2.1 \(Procedure overview\)](#).
 2. Complete the electrical connections.
 3. If necessary change the *Trigger Level (Settings)* and continue with the measure operation.

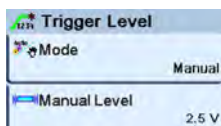

Values to set:

Mode (Automatic/Manual);
 Manual Level (trigger level value)

- Example B**
1. Set the applicable software options; see [Section 3.2.1 \(Procedure overview\)](#).

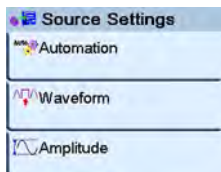

- Complete the electrical connections.
- If necessary change the *Source Settings* and continue with source operation.

Values to set:

Waveform (Square, Triangle, Sine);
Amplitude (Amplitude value)

- Automation:* Set the applicable output value; see [Section 2.11.2](#).

3.2.9 Example procedure: Measure or simulate an RTD (or Resistance)

These examples (A and B) show Channel 1 (CH1) set up to measure or simulate an RTD. A 4-Wire configuration gives the best accuracy; a 2-Wire configuration has the lowest accuracy (4-Wire RTD shown).

Note: To measure or simulate resistance (Ω), set the *Resistance* function

A

Measure an RTD on channel 1 (CH1)
Range: 850 °C
RTD Type: PT100
Connection: 4 wire

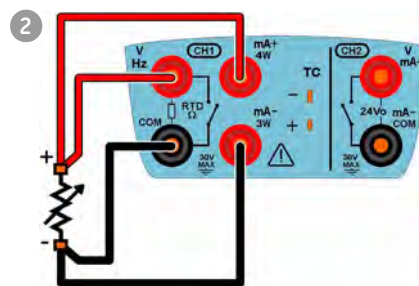
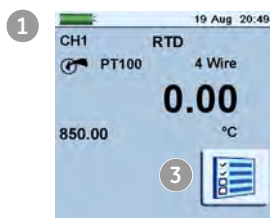

B

Simulate an RTD on channel 1 (CH1)
Range: 850 °C
RTD Type: PT100
Connection: 4 wire
Automation: Nudge
([Section 2.11.2](#))

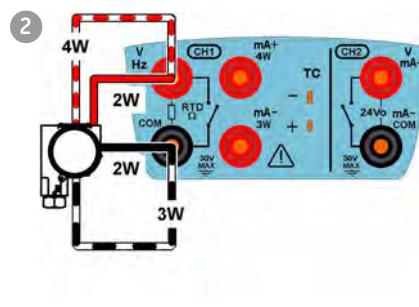
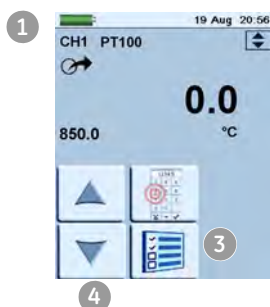

Example A 1. Set the applicable software options; see [Section 3.2.1 \(Procedure overview\)](#).

2. Complete the electrical connections.

3. If necessary change the *Settings* and continue with the measure operation.

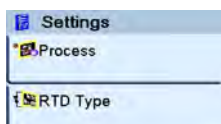

Values to set:

RTD Type (Set the applicable RTD); see [Table A1](#) (front cover) for the available options.

- Example B**
1. Set the applicable software options; see [Section 3.2.1 \(Procedure overview\)](#).
 2. Complete the electrical connections.
 3. If necessary change the *Source Settings* and continue with source operation.

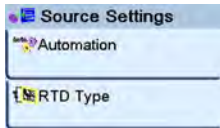

Values to set:

RTD Type (Set the applicable RTD); see [Table A1](#) (front cover) for the available options.

4. *Automation*: Set the applicable output value; see [Section 2.11.2](#).

3.2.10 Example procedure: Measure or simulate a thermocouple (or TC mV)

These examples (A and B) show Channel 1 (CH1) set up to measure or simulate a thermocouple temperature.

Note: To measure or simulate TC millivolts, set the TC mV function

- A**
- Measure a TC temperature on channel 1 (CH1)
- Range: 1372 °C
- TC Type: K Type
- Cold Junction: 32.66

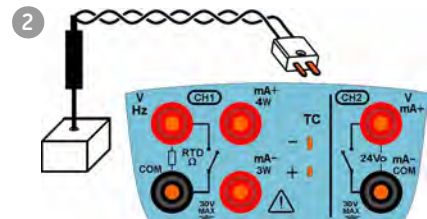
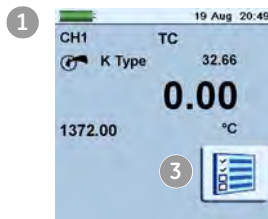

- B**
- Simulate a TC temperature on channel 1 (CH1)
- Range: 1372 °C
- TC Type: K Type
- Cold Junction: 32.66
- Automation: Nudge* ([Section 2.11.2](#))

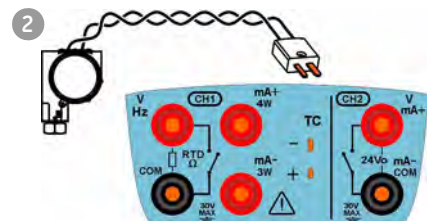
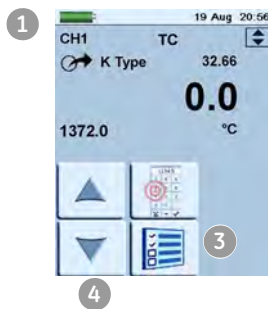

- Example A**
1. Set the applicable software options; see [Section 3.2.1 \(Procedure overview\)](#).
 2. Complete the electrical connections.

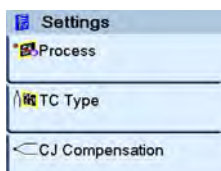

3. If necessary change the *Settings* and continue with the measure operation.

Values to set:

TC Type (Set the applicable TC)

CJ compensation (Mode: Automatic/Manual). *Automatic* uses the internal cold junction. Use *Manual* mode when you want to use an external cold junction.

CJ Value. For *Manual* mode, set an applicable value. The value is not used in *Automatic* mode.

- Example B*
1. Set the applicable software options; see [Section 3.2.1 \(Procedure overview\)](#).

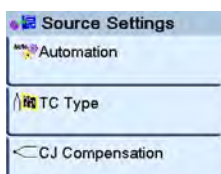

2. Complete the electrical connections.

3. If necessary change the *Source Settings* and continue with source operation.

Values to set:

TC Type (Set the applicable TC)

CJ compensation (Mode: Automatic/Manual). *Automatic* uses the internal cold junction. Use *Manual* mode when you want to use an external cold junction.

CJ Value. For *Manual* mode, set an applicable value. The value is not used in *Automatic* mode.

4. *Automation*: Set the applicable output value; see [Section 2.11.2](#).

3.2.11 Example procedure: Switch test

CH1, P1, P2 and IDOS functions use the CH2 switch connections; CH2 functions use the CH1 switch connections.

Switch operation If you set the *Switch Test* utility on one channel, the software automatically sets up the other channel for the switch connections.

Note: *If there is a measure or source function on the switch connection channel, it is automatically disabled; you get a screen message "... Function Disabled".*

If you try to set a measure or source function on the switch connection channel, you get a message "... Function not set".

Example This example shows a thermocouple switch:

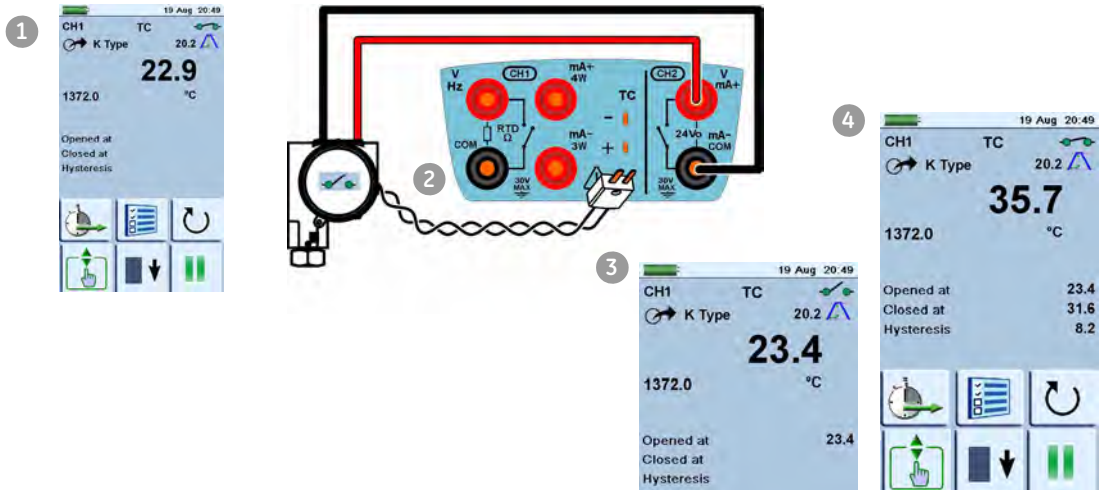

1. Set the applicable software options; see [Section 3.2.1 \(Procedure overview\)](#). This example shows one function:
 - Thermocouple (TC) is set to source a temperature. The *Utility* is set to *Switch Test*. The *Automation* is set to *Ramp*; see [Section 2.11.2](#).

2. Complete the electrical connections. Because it is a Channel 1 function (TC), you must have the switch connections on Channel 2 (CH2).

3. For the *Ramp* process, set “High” and “Low” values that are applicable to the switch value. Then, to get an accurate switch value, set a long “Travel” period.

Use Start/Stop to start and stop the “Ramp” cycle. If necessary, supply the output values in the opposite direction until the switch changes condition again.

4. The display shows:
 - the values to open and close the switch
 - the hysteresis value
5. To do the test again, use the reset button.

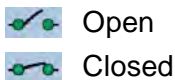

3.3 Measure pressure: IDOS option





Optional item. An IDOS Universal Pressure Module (UPM) uses Intelligent Digital Output Sensor (IDOS) technology to measure the applied pressure and supply the data to an IDOS instrument.

Before you use an IDOS module, read the user manual: K0378, Druck IDOS UPM.

Note: To attach an IDOS module to the DPI 620 calibrator, you must have an adaptor: IO620-IDOS-USB.

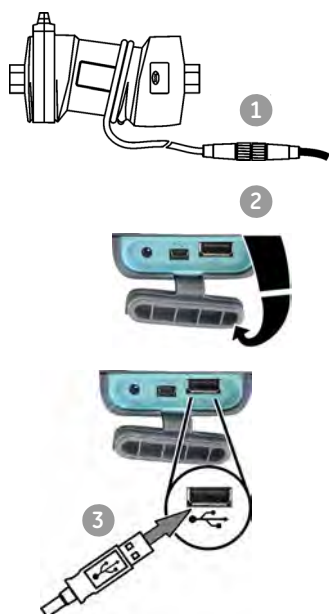
3.3.1 Assembly instructions



Step	Procedure
1.	Attach one end of the adaptor (IO620-IDOS-USB) to the applicable IDOS module.
2.	On the right-hand side of the instrument (Figure 1-3), use the rubber recess to pull down the cover for the connections.
3.	Push the Type A end of the adaptor (IO620-IDOS-USB) into the USB socket on the instrument.
4.	 Set the instrument power on.
	When this symbol flashes at the top of the display, it shows there is communication between the IDOS module and the calibrator.

3.3.2 IDOS function procedures

When the assembly is complete (Section 3.3.1), you can use these procedures to measure the pressure with the IDOS function:

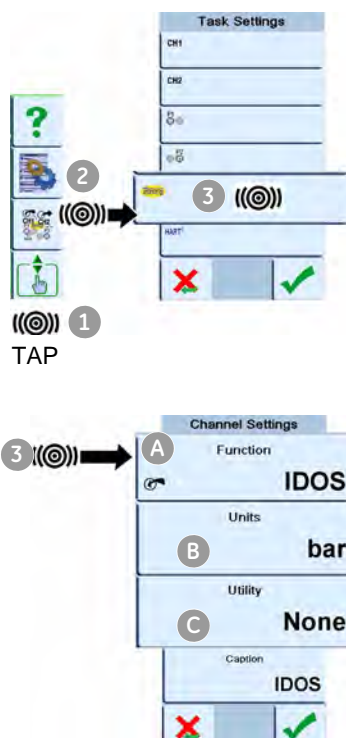

- Set the calibrator functions you want to use on the display; see Section 2.10.3. This includes:
 - a. IDOS function (to measure the pressure): item A ;
 - b. other functions (maximum: 6 functions); see Section 3.2
- If necessary, change the *Units* for the function: item B ; see Section 2.10.5
- If necessary, set a *Utility* for the function: item C ; see Section 2.10.6
 - a. *Max/Min/Avg*
 - b. *Switch Test*

c. *Leak Test*. The procedure is the same for an IDOS module or for a MC 620/PM 620 assembly; see [Section 4.4.2](#).

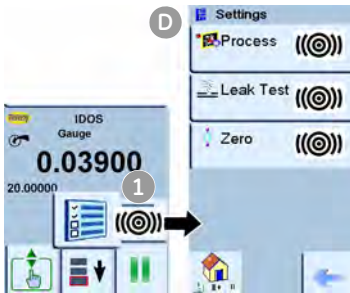

- If necessary, change the *Settings* for the IDOS function: item **D**
 - a. *Process (Tare, Alarm, Filter, Flow, Scaling)*; see [Section 2.11.1](#)
 - b. *Leak Test (Only when the Utility is set)*. The procedure is the same for an IDOS module or for a MC 620/PM 620 assembly; see [Section 4.4.2](#)
 - c. *Zero*. The procedure is the same for an IDOS module or for a PM 620 module; see [Section 4.4.3](#). We recommend that you zero a gauge sensor before you use it.

- Continue with the pressure operation.

3.3.3 Example procedure: Measure pressure with an IDOS module

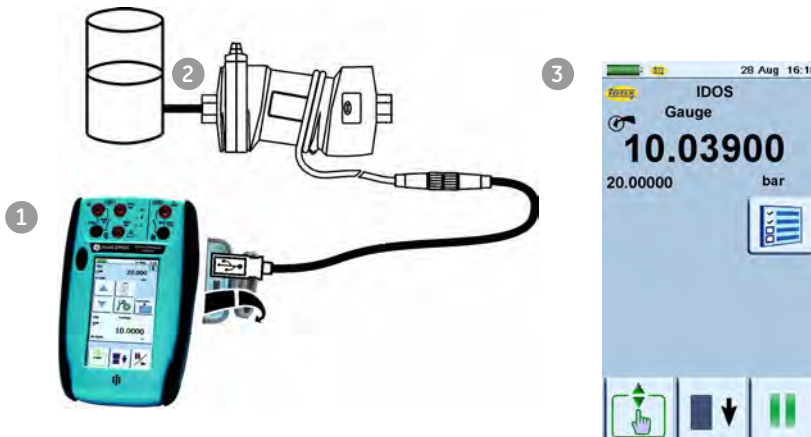

1. Assemble the DPI 620 calibrator and the IDOS module; see [Section 3.3.1](#).
2. To attach the external pressure equipment, refer to the user manual for the Druck IDOS UPM - K0378.
3. Set the applicable software options; see [Section 3.3.2 \(IDOS function procedures\)](#). This example shows the calibrator set up with the IDOS function only.

3.4 Error indications

If the display shows <<<< (under range) or >>>> (over range):

- Make sure that the range is correct.
- Make sure that all the related equipment and connections are serviceable.

<<<<< Under range: The display shows this symbol for this condition:

Reading < Negative FS - (10% of negative FS)

>>>>> Over range: The display shows this symbol for this condition:

Reading > Positive FS + (10% of positive FS)

Chapter 4: Pressure indicator operation (MC 620)

4.1 Introduction



This section gives examples of how to connect and use the instrument to measure pressure with the module carrier (MC 620) and the applicable pressure modules (PM 620).

To measure pressure with the IDOS UPM, refer to [Chapter 3](#).

To make a fully integrated pressure calibrator instrument with one of the three pressure stations, refer to the user manual for the PV 62x series of pressure stations - K0457

Before you start:

- Read and understand the “[Safety](#)” section.
- Do not use a damaged instrument.

Note: Use only original parts supplied by the manufacturer.

4.2 Parts and assembly

This figure shows the parts of the module carrier (MC 620) and pressure module (PM 620).



1.	Pressure connection (G1/8 or 1/8NPT) to attach external pressure equipment.
2.	Pressure and electrical connections for a pressure module (PM 620). These are self-sealing pressure connections.
3.	Two screws to attach the calibrator (DPI 620).
4.	Electrical connections for the calibrator (DPI 620).
5.	Pressure module (PM 620) with a pressure connection, reference port (a) and a label. The label includes: <i>Pressure range.</i> Example: 20 bar g (g: gauge; a: absolute); <i>serial number (S/N); manufacturer.</i> name, address, website

Caution: To prevent damage to the PM 620 module, only use it within the specified pressure limit on the label.

When you attach these items to the DPI 620 calibrator, you have a fully integrated pressure indicator that can measure pneumatic or hydraulic pressure.

4.2.1 Assembly instructions



Step	Procedure
1.	Align the two slots (a) on the calibrator with the two posts (b) on the module carrier.
2.	When the posts are fully engaged in the slots, tighten the two screws until they are hand tight.
3.	Attach one or two PM 620 modules with the correct range and type.
4.	Tighten each one until it is hand tight only.
	When this symbol flashes at the top of the display, it shows there is communication between the module and the calibrator.

4.3 Pressure connections



WARNING: Pressurized gases and fluids are dangerous. Before you attach or disconnect pressure equipment, safely release all the pressure.

The pressure ports for external equipment use “Quick fit” pressure adaptors; see [Section 1.4 \(Accessories\)](#). These are easy to remove, change and install.

4.3.1 Procedure (to attach external equipment)

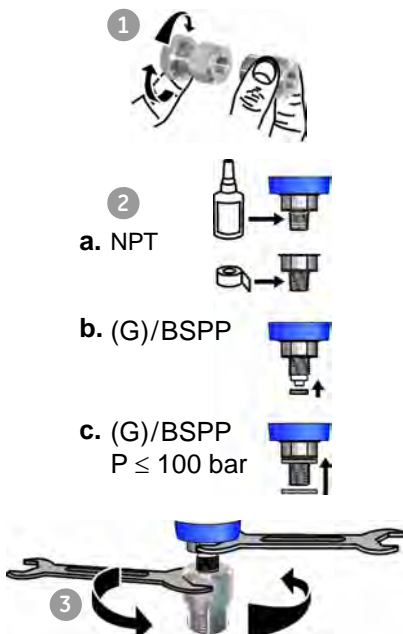

Step	Procedure
1.	Remove the adaptor from the pressure port.
2.	Use an applicable seal for the pressure connection: <ul style="list-style-type: none"> a. NPT type: Use an applicable sealant on the thread. b. BSP (parallel) type: We recommend a bonded seal at the bottom. c. BSP (parallel) type, 100 bar (1500 psi) or less: a bonded seal at the top is permitted.
3.	Attach the adaptor to the external equipment; if necessary use one of the alternative adaptors in Section 1.4 (Accessories) , then tighten to the applicable torque.

Continued



Step	Procedure
4.	Re-attach the adaptor to the MC 620 carrier and tighten it until it is hand tight only.

4.4 Measure pressure

When the pressure indicator assembly is complete ([Section 4.2.1](#)), use the menus to set up the necessary operations.

4.4.1 Procedure overview

To use the pressure indicator, complete these procedures:

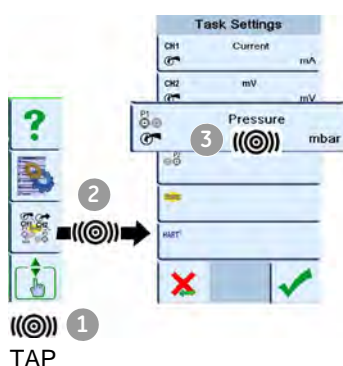

- Set the calibrator functions you want to use on the display; see [Section 2.10.3](#). This includes:
 - a. Pressure function (P1 and/or P2): item **A** ;
 - b. CH1: Channel 1 electrical function (measure or source)
 - c. CH2: Channel 2 electrical function (measure or source)
 - d. other functions (maximum: 6 functions)

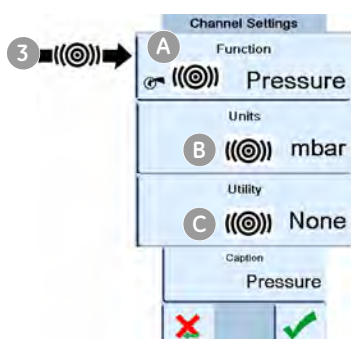

- If necessary, change the *Units* for the function: item **B** ; see [Section 2.10.5](#)
- If necessary, set a *Utility* for the function: item **C** ; see [Section 2.10.6](#)
 - a. *Max/Min/Avg*
 - b. *Switch Test*
 - c. *Leak Test*; see [Section 4.4.2](#)

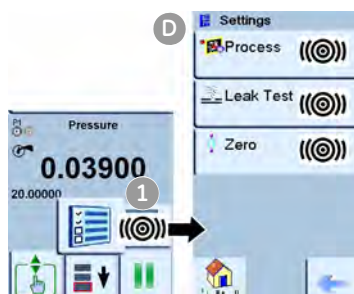

- If necessary, change the *Settings* for the pressure function: item **D**
 - a. *Process (Tare, Alarm, Filter, Flow, Scaling)*; see [Section 2.11.1](#)
 - b. *Leak Test (Only when the Utility is set)*; see [Section 4.4.2](#)
 - c. *Zero*. We recommend that you zero a gauge sensor before you use it; see [Section 4.4.3](#)

- When all the software selections are complete, make the applicable pressure and electrical connections. Examples:
Measure pressure ([Section 4.4.4](#))

4.4.2 Set up a Leak Test

- 1) *Set the Utility* Set the *Utility* to *Leak Test* ([Section 2.10.6](#)).
- 2) *Set the Leak Test options* When you have set the *Utility* to *Leak Test*, you can set these options:

Wait Time: The time before the test starts in hours:minutes:seconds (hh:mm:ss)

Test Time: The period of the leak test in hours:minutes:seconds (hh:mm:ss)

Note: To set the Leak Test options, you must have a pressure module correctly installed ([Section 4.2.1](#)).

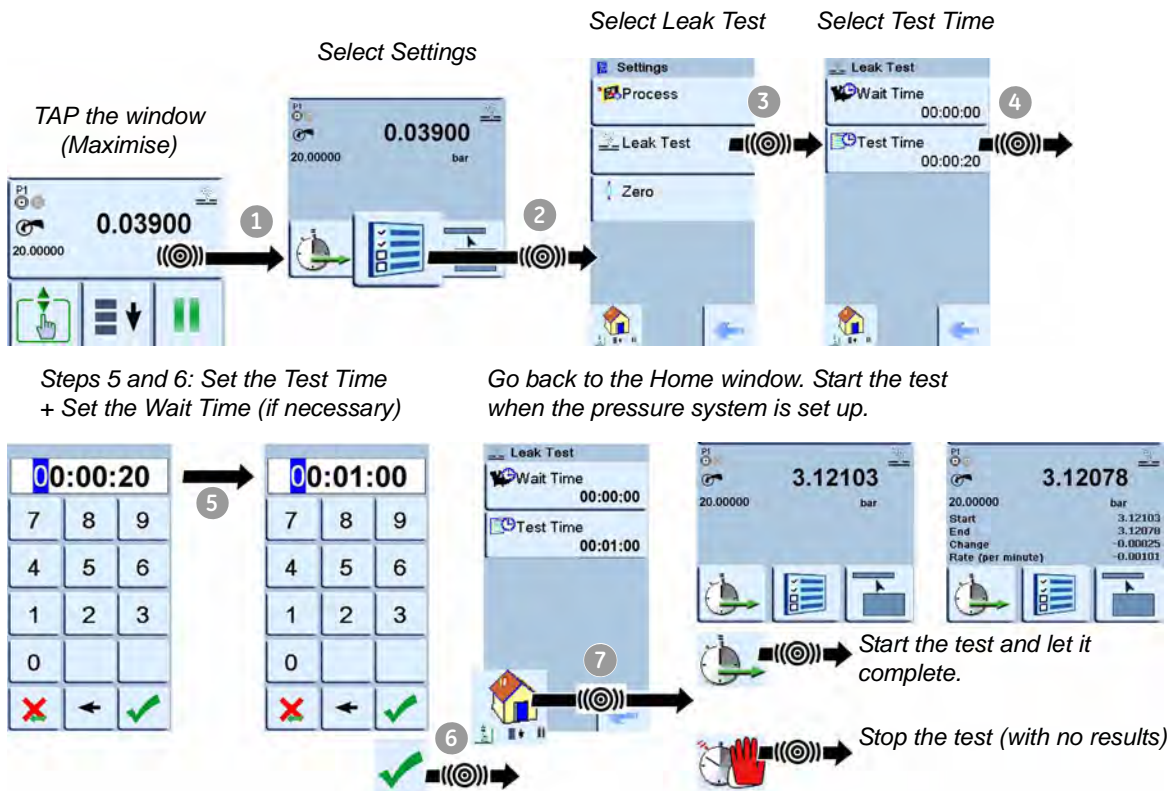

4.4.3 Set the pressure module to zero

Use this option to write a new zero pressure value to the pressure module you are using.

The sensor adjustment is permitted if it obeys this condition:

$$\text{Adjustment} \leq 10\% \text{ FS positive pressure value} \\ \text{(for the Sensor)}$$

Note: To make a temporary adjustment for zero, you can use the Tare function; see [Section 2.11.1](#)

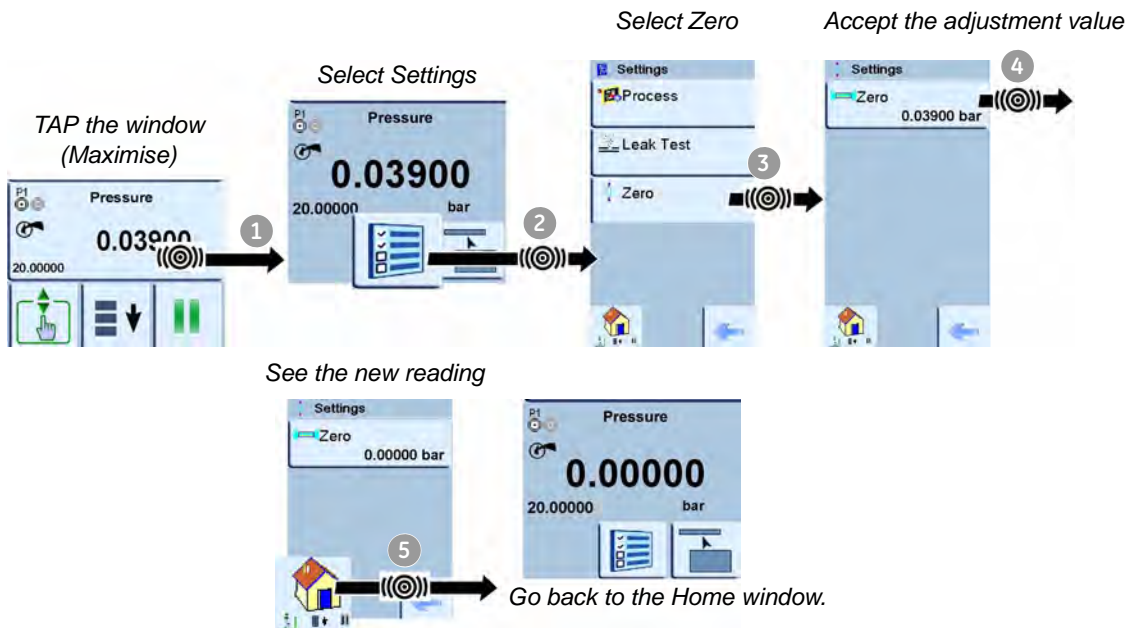

4.4.4 Example procedure: Measure pressure

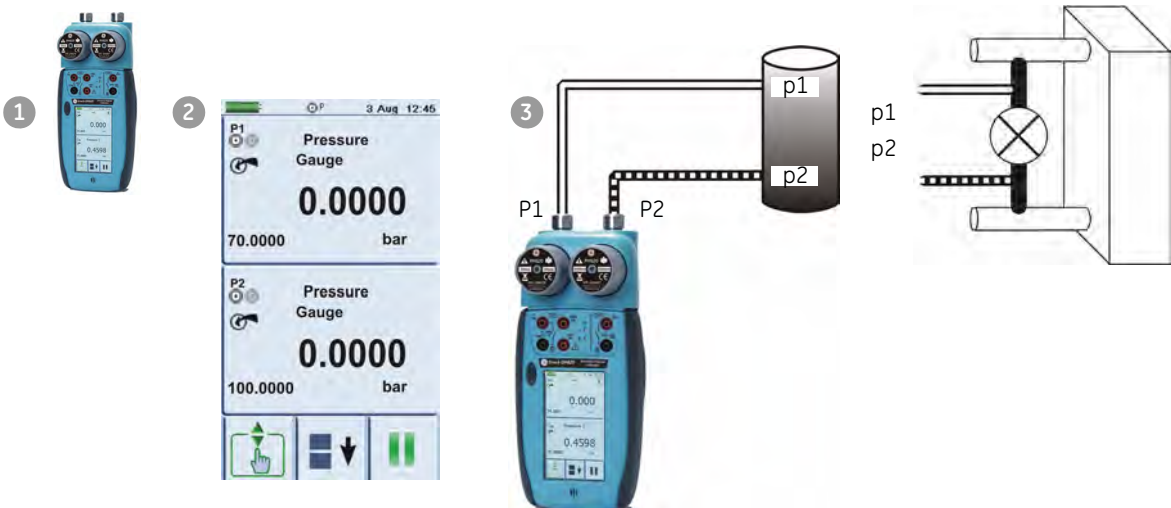

1. Assemble the pressure indicator with the correct PM 620 modules; see [Section 4.2.1](#).

2. Set the applicable software options; see [Section 4.4.1 \(Procedure overview\)](#). This example shows two pressure functions:
 - Pressure functions P1 and P2 are set up.
3. To attach the external equipment, see [Section 4.3.1](#).

4.5 Error indications

If the display shows <<<< (under range) or >>>> (over range):

- Make sure that the range is correct.
- Make sure that all the related equipment and connections are serviceable.

<<<<< Under range: The display shows this symbol for this condition:

Reading < Negative FS - (10% of negative FS)

>>>>> Over range: The display shows this symbol for this condition:

Reading > Positive FS + (10% of positive FS)

Chapter 5: Instrument communications

5.1 Introduction

This chapter gives a description of these items:

- the procedures to connect the instrument to a computer with the optional USB mini Type B cable

For a full list of optional accessories, refer to [Section 1.4](#).

5.2 Connect to a computer (USB)

You can use the USB mini Type B connector to connect the instrument to a computer. To download or upload data to the micro SD card or USB flash memory device, see [Chapter 6 \(Datalog operation\)](#).

Note: *If the power supply fails, the data will not transmit correctly. To prevent loss of data, use the DC power supply ([Section 2.6](#)).*

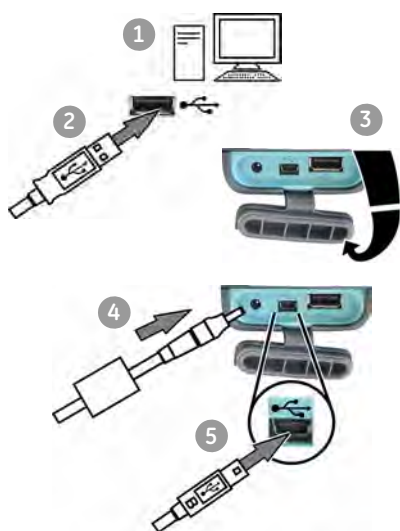

Step	Procedure
1.	Start the computer.
2.	Push the Type A end of the USB cable into a USB socket on your computer.
3.	On the right-hand side of the instrument (Figure 1-3), use the rubber recess to pull down the cover for the connections.
4.	Attach the DC power supply (Section 2.6).
5.	Push the mini Type B end of the USB cable into the USB socket on the instrument.
6.	 Set the instrument power on.

When the connections are complete you can move files between the computer and the DPI 620 calibrator with your normal file manager software (for example, Windows Explorer).

If you install a USB flash memory device and a micro SD card, the computer can only see the micro SD card. It ignores the USB memory device.

Note: *The computer cannot get access to the internal memory of the DPI 620 calibrator.*

Chapter 6: Datalog operation

6.1 Introduction

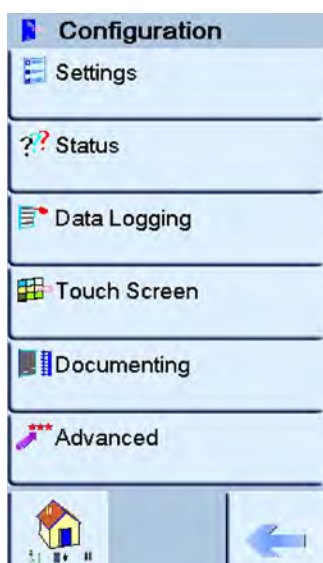

This section gives examples of how to log measurements with time and date over a set time period or on a key press. Logged data is stored in a user defined file. The instrument logs all the tasks currently enabled.

Stores this data internally but can be downloaded (transferred) to:

- USB stick
- Wireless (to be released later)
- USB serial port

To enter data logging select configuration menu and press data logging.

6.2 Set-up

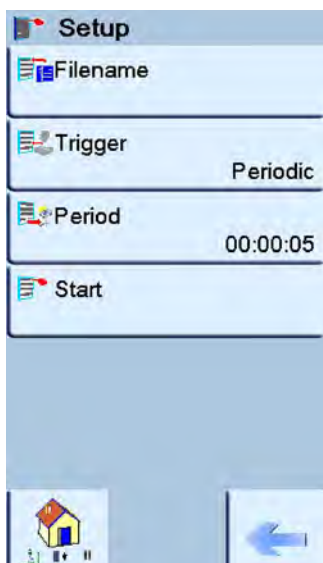

To set the data logging process:

Selection	Action
Filename	Enter name using three-page screen alpha/numeric key pad.
Trigger	Set to Key Press to activate on pressing of bottom right key or Periodic set to activate on time set in period
Period	Sets the time period of data recording using numeric keys and HH:MM:SS format.
Start	Starts data logging.

After data logging the data file can be used in the data logging menu as follows:

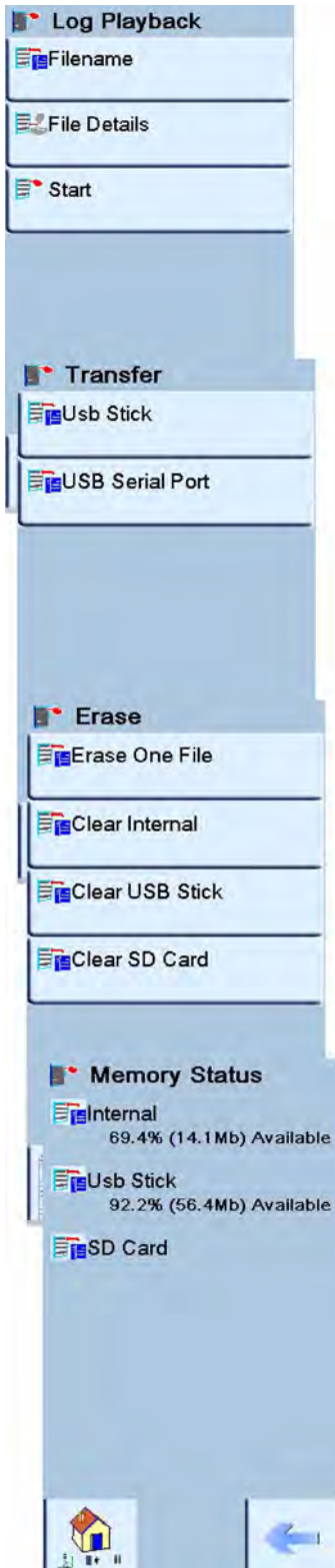

Recall

Log Playback

Filename recalls data by filename from the list.

File details shows file name, start time and number of points.

Start begins playback of the selected file by pressing the Pause/Play key.

Press and hold the Pause/Play key for at least two seconds to reverse sequence.

Transfer

The stored data held in the internal memory can be transferred to an external memory device:

- USB stick
- Wireless (to be released later)
- USB serial port

Erase

Erase one file Select file to erase

Clear internal erases all files held in the instrument’s memory

Clear USB stick erases all data on the USB stick detected at the USB port

Clear SD card erases all data on the installed SD card

Memory status

The amount of memory available (in MB and as a % of the total on the device):

- Internal
- USB stick
- SD card

6.3 Data Logging

To data log:

To log measurements made by the instrument, set the required tasks in Task Settings.

Select Configuration and select Data Logging.

Select Filename and enter a name using the three-page screen alpha/numeric key-pad.

Select Trigger and either a time (Periodic) or key press (play/pause).

Select start to set the data logging.

The display changes to the task screen with data logging flashing at the top.

If necessary, press play/pause to increment the data logging.

At the end of data logging press the cancel key.

The instrument stores the recorded data.

6.4 Data handling

Using the data logging menu, a data file can be replayed, stored in a memory device or transferred to an external device; see [Section 6.2](#).

The data file can be imported into a number of spreadsheet programs for analysis and graphic presentation.

Comma separation applies to this data.

Comma separated file

```

FILENAME,P080821A
COLUMNS,3,9
START,21 Aug 2008, 21:38:59
CHANNEL 001, Current (24V), In,mA,55
CHANNEL 005, HART, In,,0
DATA,START
ID,Date,Time,Main Reading,Secondary Reading,
0,21 Aug 2008, 21:39:14,8.7525,24V,4,0,False
1,21 Aug 2008, 21:39:29,8.5711,24V,4,0,False
2,21 Aug 2008, 21:39:44,8.4080,24V,4,0,False
3,21 Aug 2008, 21:39:59,8.2475,24V,4,0,False
4,21 Aug 2008, 21:40:14,8.0733,24V,4,0,False
5,21 Aug 2008, 21:40:29,7.9288,24V,4,0,False
  
```

Data imported into a spreadsheet

	A	B	C	D	E	F	G	H
1	FILENAME	P080821A						
2	COLUMNS	3	9					
3	START	21-Aug-08	21:38:59					
4	CHANNEL 001	Current (24V)	In	mA	55			
5	CHANNEL 005	HART	In		0			
6	DATA	START						
7	ID	Date	Time	Main Reading	Secondary Reading	Decimal Places	In Range	Alarm
8	0	21-Aug-08	21:39:14	8.7525	24V	4	0	FALSE
9	1	21-Aug-08	21:39:29	8.5711	24V	4	0	FALSE
10	2	21-Aug-08	21:39:44	8.408	24V	4	0	FALSE
11	3	21-Aug-08	21:39:59	8.2475	24V	4	0	FALSE
12	4	21-Aug-08	21:40:14	8.0733	24V	4	0	FALSE
13	5	21-Aug-08	21:40:29	7.9288	24V	4	0	FALSE
14								

Chapter 7: Documenting functions

7.1 Introduction

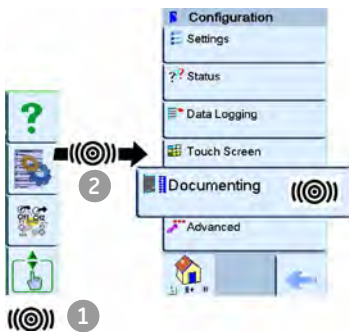

This section gives examples of the documenting functions available with the DPI 620 calibrator. There are two options:

Analysis (Section 7.2): This function lets you compare the data from two Channels on the DPI 620 calibrator: the device under test (DUT) and a reference instrument.

It calculates the % span or % reading error for the device and then gives a pass or fail indication.

Run Procedure (Section 7.3): This uses the Intecal Calibration software (Optional item) to download a calibration procedure.

Before you start:

- Read and understand the “Safety” section.
- Do not use a damaged instrument.

Note: Use only original parts supplied by the manufacturer.

7.2 Analysis

To use the *Analysis* function, set the functions for the two Channels you want to compare (Section 2.10.4). Then use these procedures:

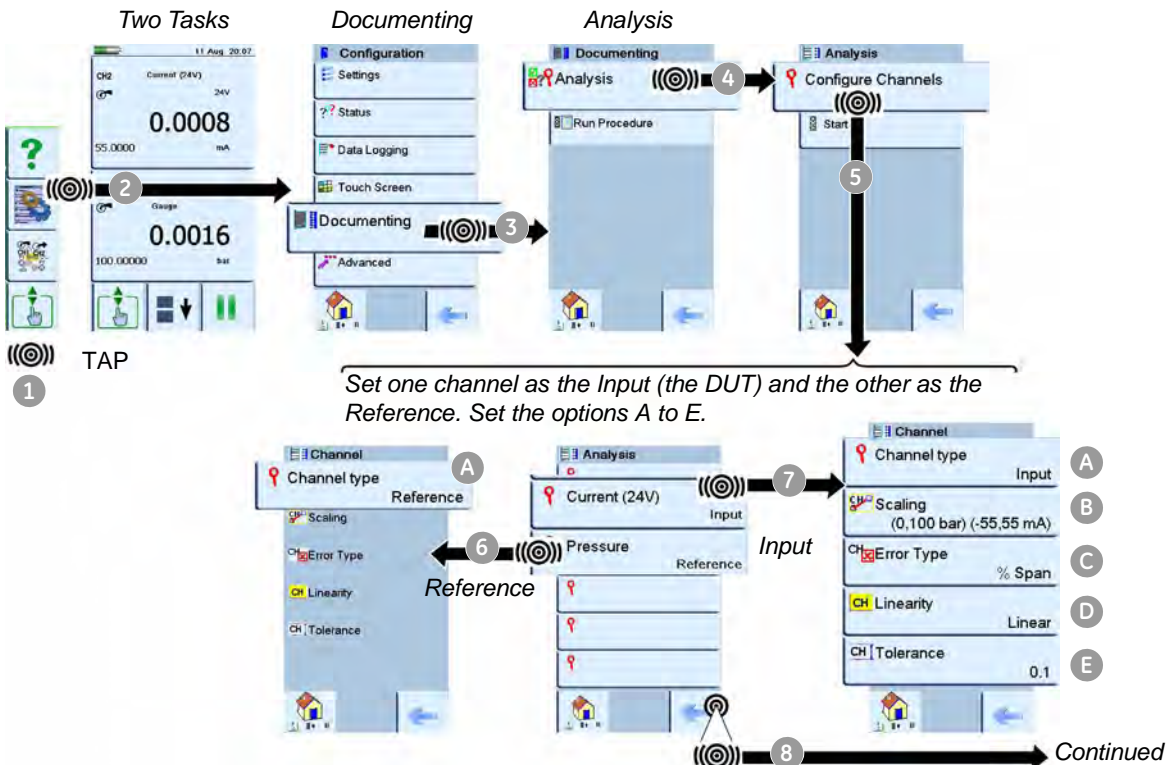

Input and Reference options **Channel type ^A** : *Input or Reference*

Scaling ^B (Input only): *Values for Reference High and Low and Input High and Low. This sets the scale for the Analysis function.*

Error Type ^C (Input only): *% Span or % Rdg (Reading)*

Linearity ^D (Input only): *Linear or Square Root*

Tolerance ^E (Input only): *an applicable value for the pass/fail calculation*

When the *Input and Reference* options are set, start the analysis.

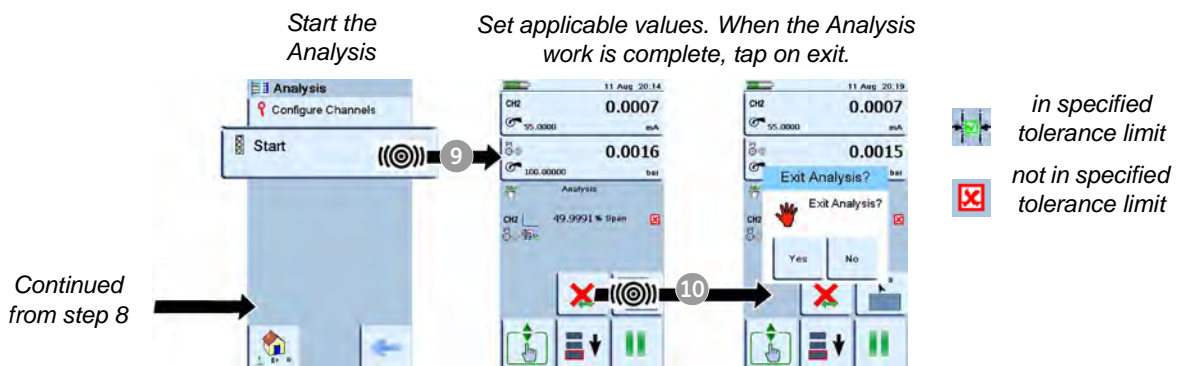

7.3 Run a procedure

The Intecal calibration *Procedure* contains all the values to calibrate a device under test (test points, ramp time). You can use the same calibration procedure for all the applicable devices under test.

To use the *Run Procedure* function, you need these items:

- a copy of the Intecal Calibration Software. This is available from our website at: www.gesensinginspection.com
There is a 30 day free trial.
- IO620-USB-RS232 (Intecal version 5 only). An adaptor to connect the DPI 620 calibrator to the RS232 interface on your computer.
- a DPI 620 calibrator device driver: available as a download from our website.

7.3.1 Sequence to upload and download file

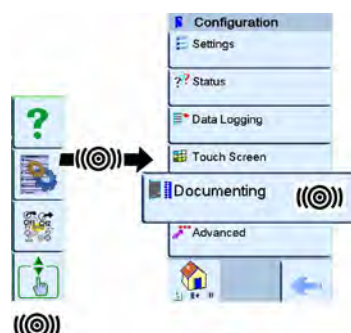

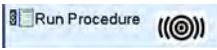
Step	Procedure
1.	P/N IO620-USB-RS232. Connect the USB Type A connector to the DPI 620 calibrator; see Chapter 5 .
2.	Connect the RS232 to the serial communications port on the computer that has Intecal installed; see Chapter 5 .
3.	Use Intecal to set up the <i>Procedure</i> and create a <i>Work Order</i> for the <i>Device</i> . The procedure includes the parameters for the calibration, the number of test points, the relationship (for example: linear) pass/fail tolerance.
4.	Use the <i>Download</i> button in Intecal to download the file to the DPI 620 calibrator. During this process, there is a communications symbol at the bottom of the display.
5.	 Tap the <i>Run Procedure</i> option
6.	In the <i>Results</i> window that opens, select the <i>Filename</i> you specified in Intecal.
7.	Enter your <i>User ID</i> and the <i>DUT Serial Number</i> .
8.	Tap on the <i>Start</i> button. The Procedure sets up the necessary Channel options (for example: mA and Volts).
9.	Use the <i>Take Reading</i> button at each point specified by the procedure. You see a prompt for each point.
10.	When all the readings are complete, tap on the <i>Exit</i> button. You can then look at the results on the display (<i>As Found/As Left</i>).
11.	To complete the process, use Intecal to <i>Upload</i> the file back into the Intecal database.

Chapter 8: HART[®] device operations

8.1 Introduction

You can use the DPI 620 calibrator to communicate with devices that use the HART protocol:

- The Universal and Common Practice commands specified in HART revision 5 to 7.

This section includes procedures to use the HART functions available in the calibrator.

Before you start:

- Read and understand the “[Safety](#)” section.
- Do not use a damaged instrument.

Note: Use only original parts supplied by the manufacturer.

8.2 About HART

The HART (Highway Addressable Remote Transducer) protocol uses a digital signal on top of a standard 4 - 20 mA current loop to get data to and from a HART enabled field device. These operations are typical:

- read the primary variable and the analogue output
- read the device serial number, type and supplier
- get calibration data (upper and lower range values, sensor limits, calibration date)
- do status and fault finding checks
- change the device configuration (range, units, damping)

One HART device (a master device) starts and controls the communications with commands. The field device (a slave device) uses each command to make a change and/or send data back.

Two master devices are permitted: a primary master (usually the main control and monitor system), and a secondary master (usually a handheld communicator). The DPI 620 calibrator operates as a secondary master.

8.3 Available HART commands

This is a list of the commands that are available with the DPI 620 calibrator:

Note: HART revision 5 field devices do not support some of these commands.

Command name	Command number	Menu	Type and revision level
Return device ID, hardware/firmware version, HART ID, Number of preambles, manufacturer/model	#0	Hart hardware info	Universal - 5
Primary Variable (PV) and units	#1	PV display screen	Universal - 5
Read loop current	#2	PV display screen	Universal - 5
Tagged poll version of #0 (Command 0)	#11	Tagged poll mode	Universal - 5
Read Tag descriptor and date	#13	Hart hardware info	Universal - 5
Read primary variable transducer serial number, upper lower transducer limits, minimum span	#14	Hart Sensor Info	Universal - 5
Primary damping value, write protect mode, alarm	#15	Hart Sensor Info	Universal - 5
Write Tag descriptor and date	#18	Hart hardware info	Universal - 5
Write primary damping factor	#34	Hart Sensor Info	Common - 5
Write primary variable range values – LRV & URV	#35	Re-range menu	Common - 5
Set primary URV “Span”	#36	Re-range menu	Common - 5
Set primary LRV “Zero”	#37	Re-range menu	Common - 5
Reset configuration changed counter	#38	Calibrate menu	Common - 5
Enter/Exit fixed current mode - loopback test	#40	Trim Menu	Universal - 5
Perform self test	#41	Calibrate menu	Common - 5
Perform device reset	#42	Calibrate menu	Common - 5
Set primary variable zero “Tare”	#43	Re-range menu	Common - 5
Write primary variable units	#44	Advanced device menu	Common - 5
Trim loop current zero	#45	Trim Menu	Common - 5
Trim loop current gain	#46	Trim Menu	Common - 5

Command name	Command number	Menu	Type and revision level
Get extended status info	#48	Hart settings menu	Common - 5
Write primary variable transducer serial number	#49	Hart Sensor Info	Common - 5
Read dynamic variable assignments.	#50	Advanced device menu	Common - 5
Write dynamic variable assignments	#51	Advanced device menu	Common - 5
Read max update time period	#54	Re-range menu	Common - 6
Set poll address	#6	Hart settings menu	Universal - 5
Read analogue channel additional damping factor, range values, alarm code & transfer function	#63	Advanced analogue menu	Common - 5
Write analogue channel additional damping factor	#64	Advanced analogue menu	Common - 5
Write analogue channel range values	#65	Advanced analogue menu	Common - 5
Enter/Exit fixed analogue output mode	#66	Loop test	Common - 5
Trim analogue channel zero	#67	Trim Menu - multiple output device	Common - 5
Trim analogue channel gain	#68	Trim Menu - multiple output device	Common - 5
Write analogue channel transfer function	#69	Analogue channel info	Common - 5
Get poll address	#7	Hart settings menu	Universal - 6
Read analogue channel endpoint values	#70	Advanced analogue menu	Common - 5
Lock device for exclusive access	#71	Device location menu	Common - 6
Squawk	#72	Device location menu	Common - 6
Find device	#73	Device location menu	Common - 6
Read lock device state	#76	Device location menu	Common - 6

Command name	Command number	Menu	Type and revision level
Get measurand classification	#8	Advanced device menu	Universal - 6
Read device variable trim points	#80	Trim Menu	Common - 6
Read device variable trim guidelines	#81	Trim Menu	Common - 6
Write device variable trim point	#82	Trim Menu	Common - 6
Reset device variable trim	#83	Trim Menu	Common - 6
Read burst mode configuration	#105	Hart settings menu	Common - 6
Write burst mode configuration	#109	Hart settings menu	Common - 5

8.4 HART Connections

Before you set up the electrical connections between the HART device and the DPI 620 calibrator, examine the power supply connections for the device you want to work with.

8.4.1 Power supply from the calibrator

In this example, the DPI 620 calibrator supplies the loop power and a 250Ω HART resistor.

Measure current on channel 2 (CH2) with 24V loop power
 Range: ±55 mA
 HART Function is set
 250Ω resistor is set

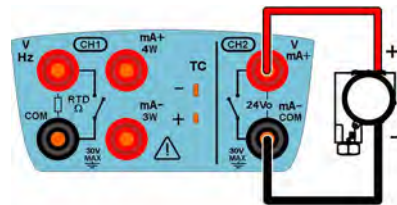

1. Set the functions for channel 2 and HART:

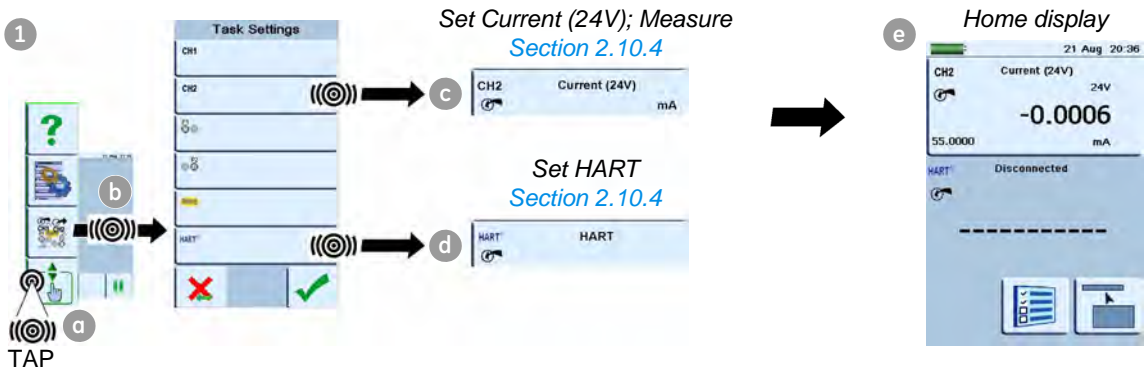

2. Set the *HART Resistor* in the *Advanced* menu:

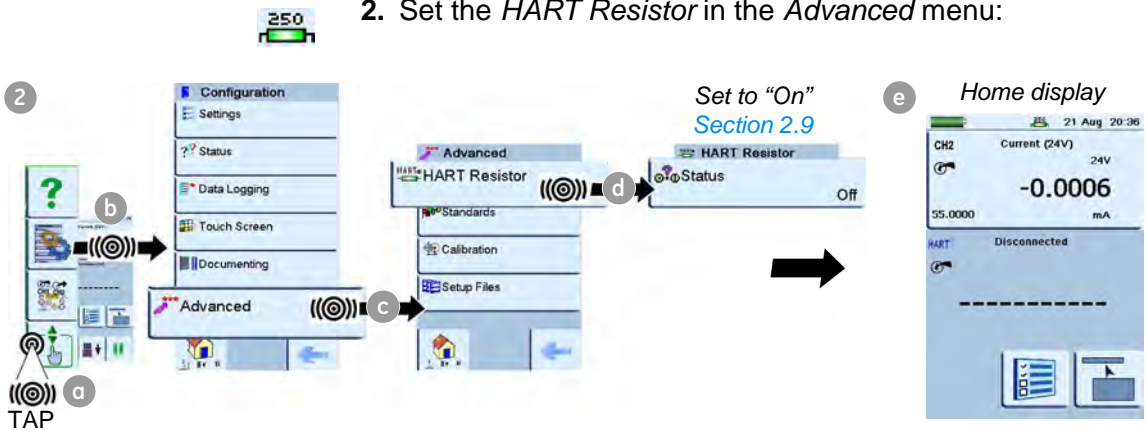

3. Complete the electrical connections and continue with the HART menu operation; see Section 8.5.

8.4.2 External loop power

In this example, there is an external power supply.

Measure current on channel 2 (CH2)
 Range: ± 55 mA
 HART Function is set
 250 Ω resistor is set

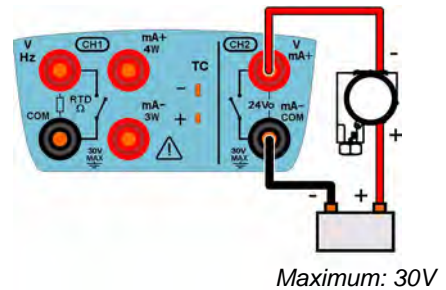

1. Set the functions for channel 2 and HART:

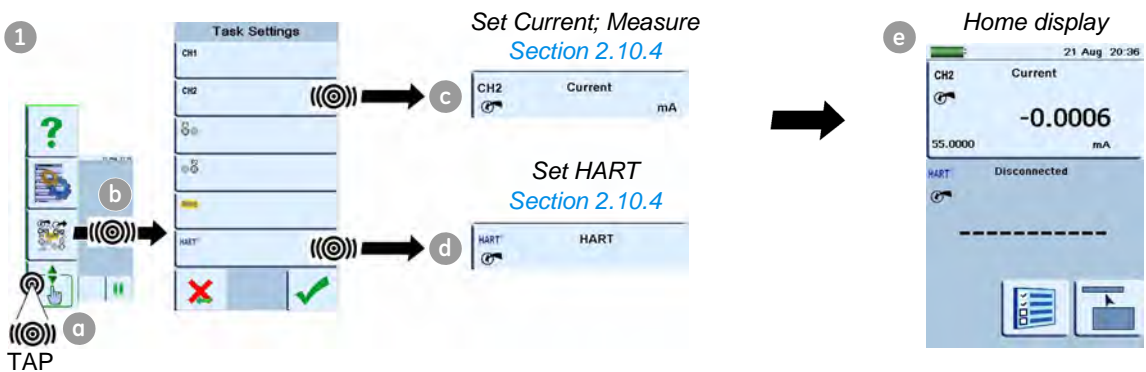

2. Set the *HART Resistor* in the *Advanced* menu:

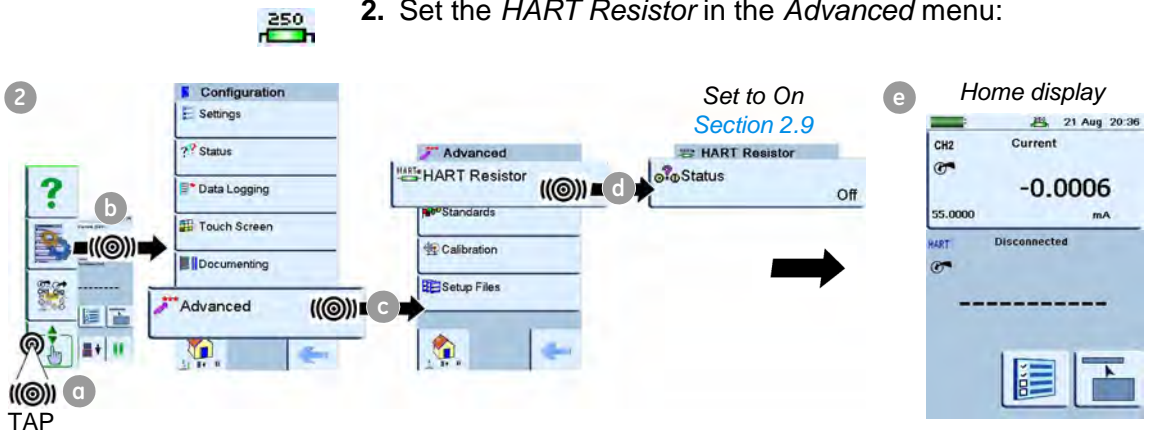

3. Complete the electrical connections and continue with the HART menu operation; see [Section 8.5](#).

8.4.3 Communicator attached to a network

In this example, the calibrator connects directly to a network. There must be a 250Ω resistor in series with the loop power supply and the HART device.

No functions on channel 2 (CH2)
HART Function is set
250Ω resistor is set to *Off*

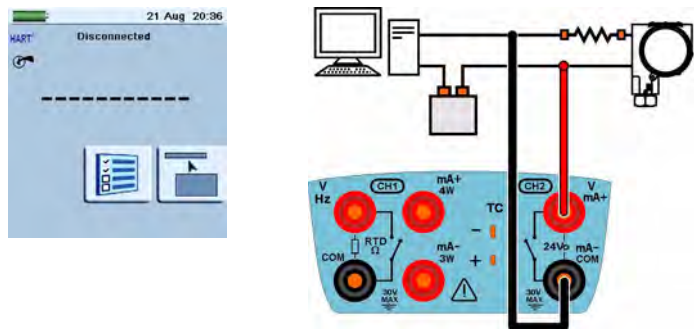

1. Set the function for HART:

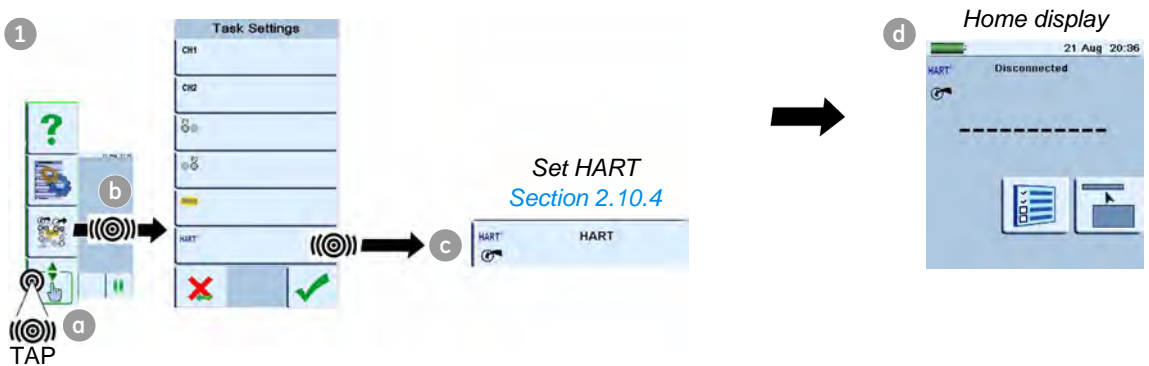

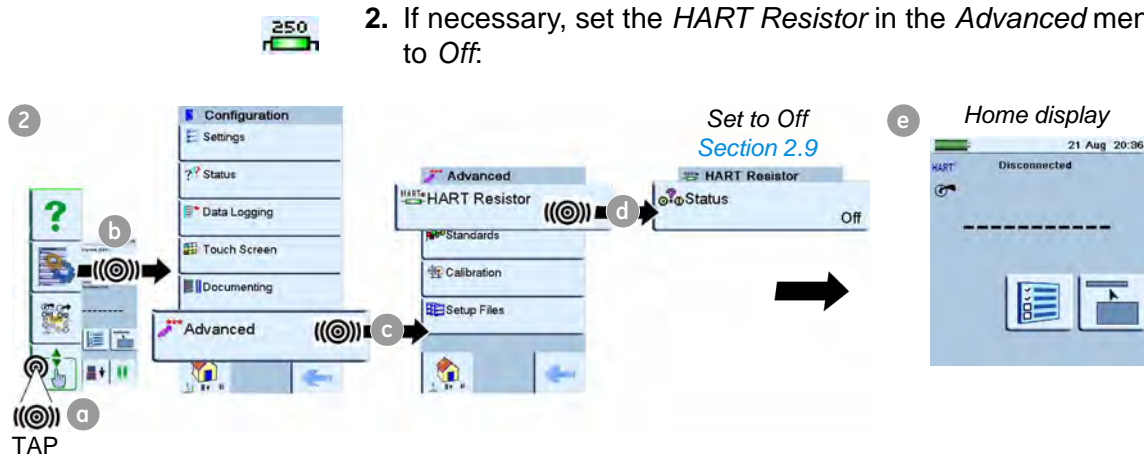

3. Complete the electrical connections and continue with the HART menu operation; see [Section 8.5](#).

8.5 Start HART menu operations

When the power supply connections are complete, you can do a search for the applicable HART device and start the communications process. You use the same sequence of steps for all the power supply options:

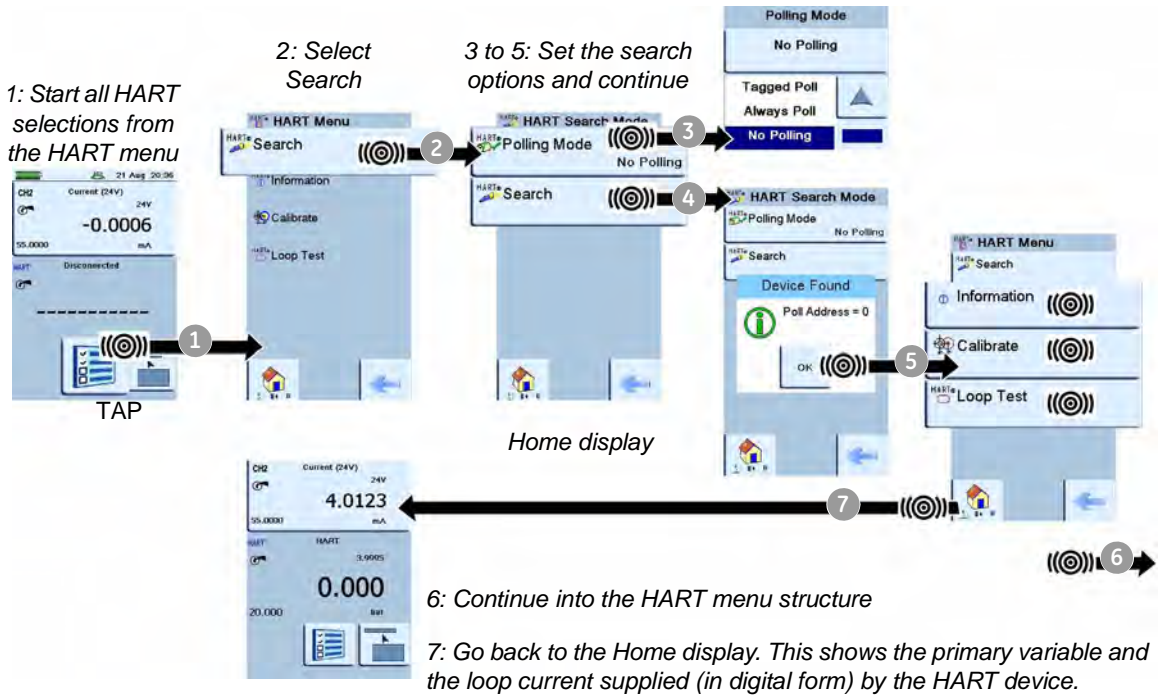

8.5.1 HART menu - Information (Sensor, Hardware, Settings)

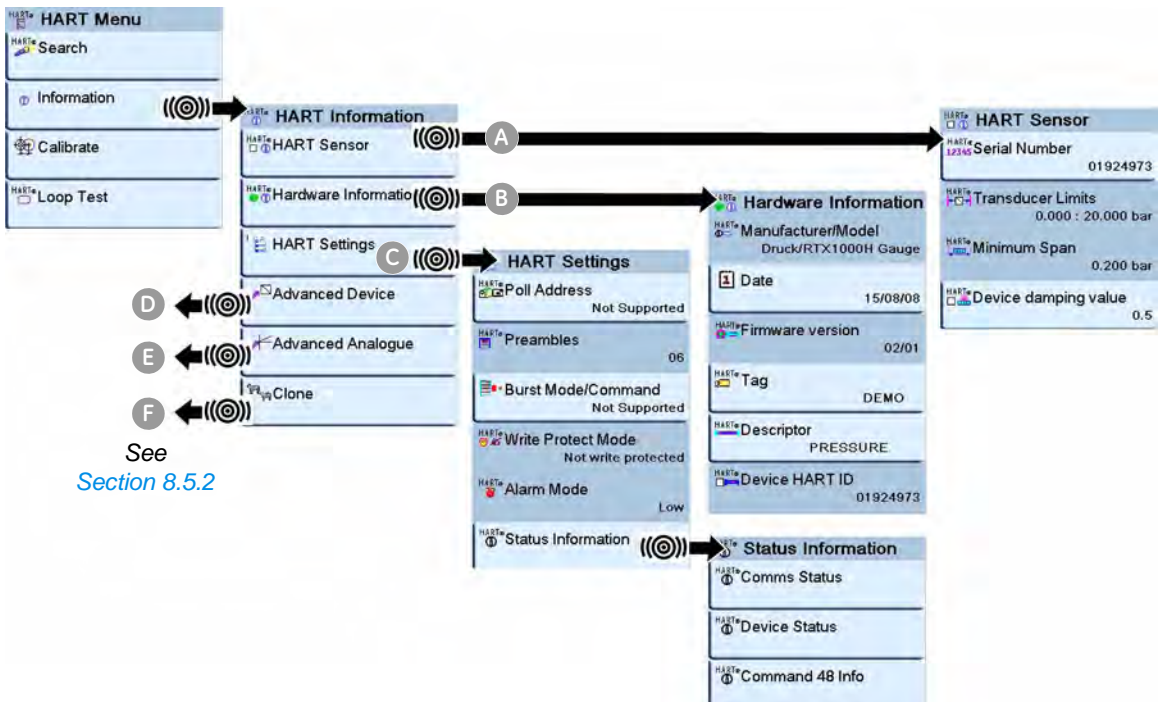

8.5.2 HART menu - Information (Advanced, Clone)

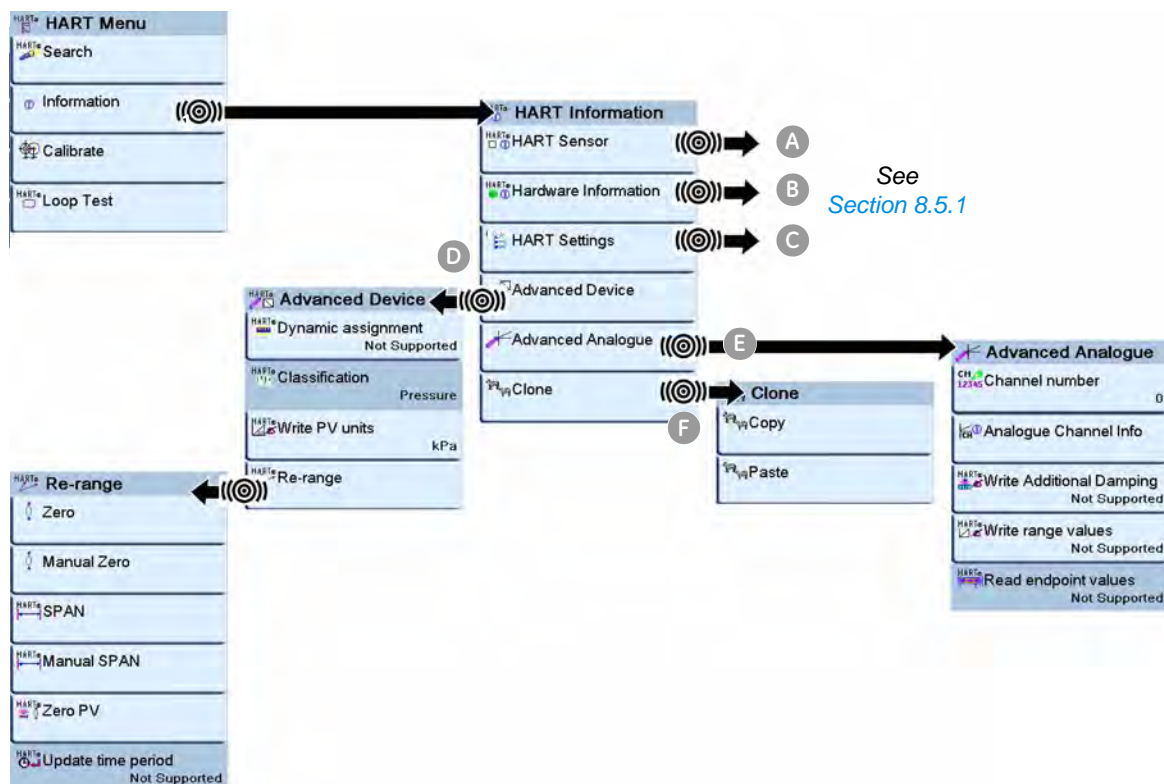

Example procedure: Clone

The *Clone* function lets you copy the parameters from one field device to another of the same type and range.

1. Attach the first device with the necessary parameters and start communications ([Section 8.5](#)).
2. Go to the *Clone* menu option and tap on *Copy*. It copies these parameters:
 - Tag
 - PV unit
 - LRV (lower range value)
 - URV (upper range value)
 - Damping value
 - Transfer function
3. Go back to the Home display and attach the other field device.
4. Start communications with the new device ([Section 8.5](#)).
5. Go to the *Clone* menu option and tap on *Paste*.

To complete the *Clone* operation from one device to another, make sure the DPI 620 calibrator stays on for the whole procedure.

8.5.3 HART menu - Calibrate and Loop Test

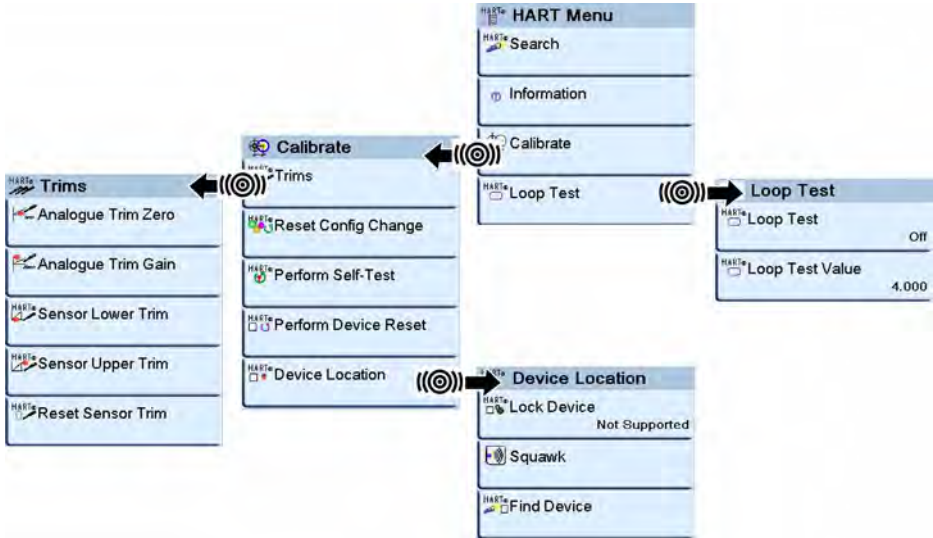

Example procedure: Loop test

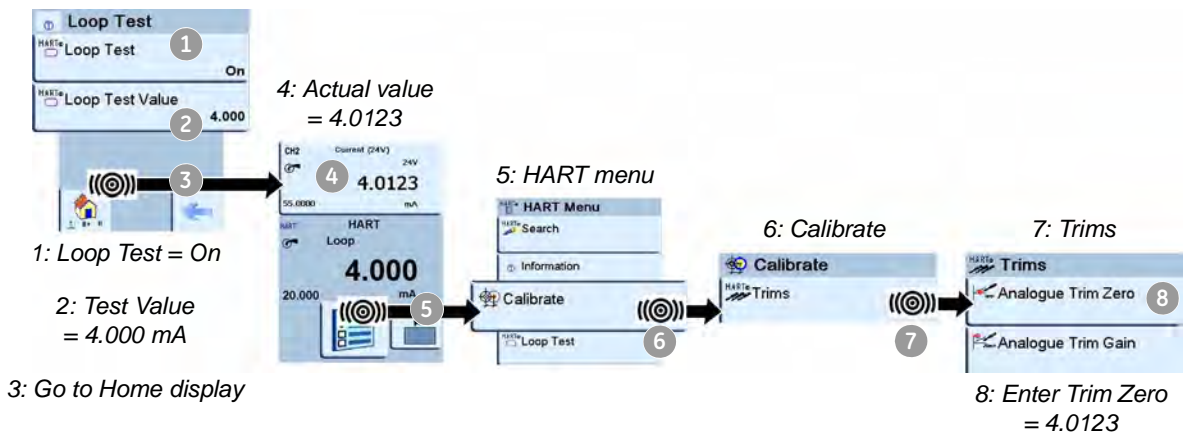

The loop current is set to 4.000 mA but the actual loop current is 4.0123 mA. To trim the error, make a note of the actual reading (4.0123) and enter this value in *Analogue Trim Zero* (Step 8).

Chapter 9: Maintenance procedures

9.1 Introduction

This section gives procedures to maintain the unit in a good condition. Return the instrument to the manufacturer or an approved service agent for all repairs.

Do not dispose of this product as household waste. Use an approved organisation that collects and/or recycles waste electrical and electronic equipment.

For more information, contact one of these:

- our customer service department:
(Contact us at www.gesensinginspection.com)
- your local government office.

9.2 Clean the unit

Clean the case with a moist, lint-free cloth and a weak detergent. Do not use solvents or abrasive materials.

9.3 Replace the batteries

To replace the batteries, refer to [Section 2.5](#). Then re-attach the cover.

All the configuration options stay in memory.

Chapter 10: General specification

10.1 Introduction

For a full specification of the DPI 620 calibrator and its related accessories (MC 620 carrier, PM 620 module, and PV 62x pressure stations) refer to the datasheet supplied on the CD (CD: P/N UD-0002).

Table 10-1: General specification

Display	LCD: Colour display with touch-screen
Operating temperature	-10 to 50°C (14 to 122°F)
Storage temperature	-20 to 70°C (-4 to 158°F)
Ingress Protection	IP65 (DPI 620 calibrator only)
Humidity	0 to 90% relative humidity (RH) non-condensing
Shock/Vibration	Def Stan 66-31, 8.4 cat III
EMC	Electromagnetic compatibility: BS EN 61326-1:2006
Electrical safety	Electrical - BS EN 61010:2001
Pressure safety	Pressure Equipment Directive - Class: Sound Engineering Practice (SEP)
Approved	CE Marked
Battery power	Lithium-Polymer battery (GE Part number: 191-356) Capacity: 5040 mAh (minimum), 5280 mAh (typical); Nominal voltage: 3.7 V. Charge temperature: 0 to 40°C (32 to 104°F) When the instrument senses the temperature is outside this range, it stops charging. Discharge temperature: -10 to 50°C (14 to 122°F). Charge/discharge cycles: > 500 > 70% capacity

Customer service



99 Washington Street
Melrose, MA 02176
Phone 781-665-1400
Toll Free 1-800-517-8431



