

Contents

1.	INTRODUCTION	1
1.1	GENERAL	1
1.2	IMPEDANCE PARAMETERS.....	2
1.3	SPECIFICATION.....	3
1.4	ACCESSORIES.....	11
2.	OPERATION.....	12
2.1	PHYSICAL DESCRIPTION	12
2.2	MAKING MEASUREMENT	13
2.2.1	<i>Open and Short Calibration</i>	13
2.2.2	<i>Relative Mode</i>	13
2.2.3	<i>Range Hold</i>	13
2.2.4	<i>DC Resistance Measurement</i>	14
2.2.5	<i>AC Impedance Measurement</i>	14
2.2.6	<i>Capacitance Measurement</i>	14
2.2.7	<i>Inductance Measurement</i>	14
3.	OPERATION MODES	15
3.1	REMOTE MODE COMMAND SYNTAX	18
3.2	REMOTE MODE COMMANDS	18
4.	APPLICATION	24
4.1	TEST LEADS CONNECTION.....	24
4.2	OPEN/SHORT COMPENSATION.....	26
4.3	SELECTING THE SERIES OR PARALLEL MODE	27
5.	LIMITED ONE-YEAR WARRANTY AND SERVICE INFORMATION.....	29
6.	SAFETY PRECAUTION.....	31

1. Introduction

1.1 General

The B&K Precision Corp. 889A Synthesized In-Circuit LCR/ESR Meter is a high accuracy test instrument used for measuring inductors, capacitors and resistors with a basic accuracy of 0.1%. Also, with the built-in functions of DC/AC Voltage/Current measurements and Diode/Audible Continuity checks, the 889A can not only help engineers and students to understand the characteristics of electronics components but also being an essential tool on any service bench.

The 889A is defaulted to auto ranging. However, it can be set to auto or manual ranging by pressing the **Range Hold** key. When LCR measurement mode is selected, one of the test frequencies, 100 Hz, 120 Hz, 1 KHz, 10 KHz, 100 KHz or 200 KHz, may be selected on all applicable ranges. One of the test voltages, 50mVrms, 0.25 Vrms, 1 Vrms or 1 VDC (DCR only), may also be selected on all applicable ranges. The dual display feature permits simultaneous measurements. When DC/AC voltage/current measurement mode or the Diode/Audible Continuity Check mode is selected, only the secondary display will be used to show the result of the measurement.

The highly versatile 889A can perform virtually all the functions of most bench type LCR bridges. With a basic accuracy of 0.1%, this economical LCR meter may be adequately substituted for a more expensive LCR bridge in many situations. Also, with the basic accuracy of 0.4% in voltage and current measurements, the 889A performs the functions of a general purpose Digital Multi-Meter and can be used to replace the DMM on a service bench.

The 889A has applications in electronic engineering labs, production facilities, service shops, and schools. It can be used to check ESR values of capacitors, sort and/or select components, measure unmarked and unknown components, and measure capacitance, inductance, or resistance of cables, switches, circuit board foils, etc.

The key features are as following:

1. Voltage Measurements:

- AC : True RMS, up to 600Vrms @ 40 ~ 1K Hz
- DC : up to 600V
- Input Impedance : 1M-Ohm

2. Current Measurements:

- AC : True RMS, up to 2Arms @ 40 ~ 1K Hz
- DC : up to 2A
- Current Shunt : 0.1 Ohm @ > 20mA; 10 Ohm @ ≤ 20mA

3. Diode/Audible Continuity Checks:

- Open Circuit Voltage: 5Vdc
- Short Circuit Current: 2.5mA
- Beep On: ≤ 25 Ω
- Beep Off: ≥ 50 Ω

4. LCR Measurements:

- Test conditions
 - Frequency : 100Hz / 120Hz / 1KHz / 10KHz / 100KHz / 200KHz
 - Level : 1Vrms / 0.25Vrms / 50mVrms / 1VDC (DCR only)
- Measurement Parameters : Z, Ls, Lp, Cs, Cp, DCR, ESR, D, Q and ?
- Basic Accuracy : 0.1%
- Dual Liquid Crystal Display
- Auto Range or Range Hold
- RS-232 Interface Communication
- Open/Short Calibration
- Primary Parameters Display:
 - Z : AC Impedance
 - DCR : DC Resistance
 - Ls : Serial Inductance
 - Lp : Parallel Inductance

- Cs : Serial Capacitance
- Cp : Parallel Capacitance
- Second Parameter Display:
 - ? : Phase Angle
 - ESR : Equivalence Serial Resistance
 - D : Dissipation Factor
 - Q : Quality Factor
- Combinations of Display:
 - Serial Mode : Z-?, Cs - D, Cs - Q, Cs - ESR, Ls - D, Ls - Q, Ls - ESR
 - Parallel Mode : Cp - D, Cp - Q, Lp - D, Lp - Q

1.2 Impedance Parameters

Due to the different testing signals on the impedance measurement instrument, there are DC and AC impedances. The common digital multi-meter can only measure the DC impedance, but the 889A can do both. It is very important to understand the impedance parameters of the electronic components.

When we analysis the impedance by the impedance measurement plane (Figure 1.1), it can be visualized by the real element on the X-axis and the imaginary element on the y-axis. This impedance measurement plane can also be seen as the polar coordinates. The Z is the magnitude and θ is the phase of the impedance.

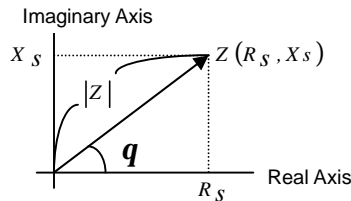

Figure 1.1

$$Z = R_S + jX_S = |Z| \angle q \ (\Omega)$$

$$R_S = |Z| \cos q \qquad |Z| = \sqrt{R_S^2 + X_S^2}$$

$$X_S = |Z| \sin q \qquad q = \tan^{-1} \left(\frac{X_S}{R_S} \right)$$

Z = (Impedance)

R_S = (Resistance)

X_S = (Reactance)

Ω = (Ohm)

There are two different types of reactance: Inductive (X_L) and Capacitive (X_C). It can be defined as follows:

$$X_L = \omega L = 2\pi fL \qquad L = \text{Inductance (H)}$$

$$X_C = \frac{1}{\omega C} = \frac{1}{2\pi fC} \qquad C = \text{Capacitance (F)}$$

$$f = \text{Frequency (Hz)}$$

Also, there are **Quality** factor (Q) and the **Dissipation** factor (D) that need to be discussed. For component, the Quality factor serves as a measurement of the reactance purity. In the real world, there is always some associated resistance that dissipates power, decreasing the amount of energy that can be recovered. The Quality factor can be defined as the ratio of the stored energy (reactance) and the dissipated energy (resistance). Q is generally used for inductors and D for capacitors.

$$\begin{aligned}
 Q &= \frac{1}{D} = \frac{1}{\tan d} \\
 &= \frac{|X_s|}{R_s} = \frac{\omega L_s}{R_s} = \frac{1}{\omega C_s R_s} \\
 &= \frac{|B|}{G} \\
 &= \frac{R_p}{|X_p|} = \frac{R_p}{\omega L_p} = \omega C_p R_p
 \end{aligned}$$

There are two types of the circuit mode, the series mode and the parallel mode. See Figure 1.2 to find out the relationship of the series and parallel modes.

Real and imaginary components are serial

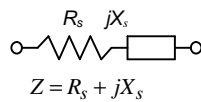

Real and imaginary components are parallel

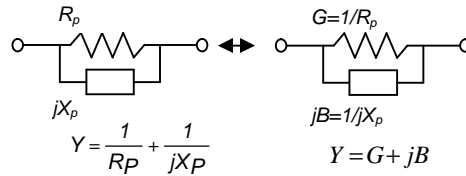

Figure 1.2

1.3 Specification

- Measuring Range:

Parameter	Range	
Z	0.000 Ω	to 500.0 MΩ
L	0.030 μH	to 9999 H
C	0.003 pF	to 80.00 mF
DCR	0.000 Ω	to 500.0 MΩ
ESR	0.000 Ω	to 9999 Ω
D	0.000	to 9999
Q	0.000	to 9999
?	-180.0 °	to 180.0 °
Voltage/Current Measurements		
V	0.0 mV	to +/- 600 V
A	0.000 mA	to +/- 2 A

- Accuracy (Ae):

1. DC Voltage Measurement:

Range	: 2V, 20V, 200V, and 600V
Resolution	: 1mV, 10mV, 100mV, and 1V
Accuracy	: +/- (0.4% + 3 digits)
Input Impedance	: 1 M-Ohm

2. AC Voltage Measurement (True RMS):

Range : 2V, 20V, 200V, and 600V
 Resolution : 1mV, 10mV, 100mV, and 1V
 Accuracy : +/- (0.8% + 5 digits)
 Input Impedance : 1 M-Ohm

3. DC Current Measurement:

Range : 2mA, 20mA, 200mA, and 2000mA
 Resolution : 1uA, 10uA, 100uA, and 1mA
 Accuracy : +/- (0.4% + 3 digits)
 Current Shunt : 0.1 Ohm @ >20mA, 10 Ohm @ ≤20mA

4. AC Current Measurement (True RMS):

Range : 2mA, 20mA, 200mA, and 2000mA
 Resolution : 1uA, 10uA, 100uA, and 1mA
 Accuracy : +/- (0.8% + 5 digits)
 Current Shunt : 0.1 Ohm @ >20mA, 10 Ohm @ ≤20mA

Note:

The accuracy of DC/AC voltage/current measurements is only applied when in 5% - 100% of the range.

5. LCR Measurement:

Z Accuracy (Ae):

Freq. \ Zx	20M ~	10M ~	1M ~	100K ~	10K ~	1K ~ 100	100 ~ 1	1 ~ 0.1
	10M (Ω)	1M (Ω)	100K (Ω)	10K (Ω)	1K (Ω)	(Ω)	(Ω)	(Ω)
DCR	2% ±1	1% ±1	0.5% ±1	0.2% ±1	0.1% ±1	0.2% ±1	0.5% ±1	1% ±1
100Hz	❶							❶
120Hz								
1KHz								
10KHz	5% ±1 ❶	2% ±1						
100KHz	NA	5% ±1	2% ±1	1% ±1	0.4% ±1	1% ±1	2% ±1	5% ±1
200KHz ❶								

Note:

1. The accuracy applies when the test level is set to 1Vrms.
2. Ae multiplies 1.25 when the test level is set to 250mVrms.
3. Ae multiplies 1.50 when the test level is set to 50mVrms.
4. When measuring L and C, multiply Ae by $\sqrt{1+Dx^2}$ if the Dx > 0.1.

❶ : Ae is applied only when the test level is set to 1Vrms.

C Accuracy:

100Hz	79.57pF	159.1pF	1.591nF	15.91nF	159.1nF	1.591uF	15.91uF	1591uF
	159.1pF	1.591nF	15.91nF	159.1uF	1.591uF	15.91uF	1591uF	15.91mF
	2% ± 1	1% ± 1	0.5% ± 1	0.2% ± 1	0.1% ± 1	0.2% ± 1	0.5% ± 1	1% ± 1
	❶							❶
120Hz	66.31pF	132.6pF	1.326nF	13.26nF	132.6nF	1.326uF	13.26uF	1326uF
	132.6pF	1.326nF	13.26nF	132.6nF	1.326uF	13.26uF	1326uF	13.26mF
	2% ± 1	1% ± 1	0.5% ± 1	0.2% ± 1	0.1% ± 1	0.2% ± 1	0.5% ± 1	1% ± 1
	❶							❶
1KHz	7.957pF	15.91pF	159.1pF	1.591nF	15.91nF	159.1nF	1.591uF	159.1uF
	15.91pF	159.1pF	1.591nF	15.91nF	159.1nF	1.591uF	159.1uF	1.591mF
	2% ± 1	1% ± 1	0.5% ± 1	0.2% ± 1	0.1% ± 1	0.2% ± 1	0.5% ± 1	1% ± 1
	❶							❶
10KHz	0.795pF	1.591pF	15.91pF	159.1pF	1.591nF	15.91nF	159.1nF	15.91uF
	1.591pF	15.91pF	159.1pF	1.591nF	15.91nF	159.1nF	15.91uF	159.1uF
	5% ± 1	2% ± 1	0.5% ± 1	0.2% ± 1	0.1% ± 1	0.2% ± 1	0.5% ± 1	1% ± 1
	❶							❶
100KHz	NA	0.159pF	1.591pF	15.91pF	159.1pF	1.591nF	15.91nF	1.591uF
		1.591pF	15.91pF	159.1pF	1.591nF	15.91nF	1.591uF	15.91uF
	NA	5% ± 1	2% ± 1	1% ± 1	0.4% ± 1	1% ± 1	2% ± 1	5% ± 1
	❶							
200KHz	NA	0.079pF	0.795pF	7.957pF	79.57pF	795.7pF	7.957nF	795.7nF
		0.795pF	7.957pF	79.57pF	795.7pF	7.957nF	795.7nF	7.957uF
	NA	5% ± 1	2% ± 1	1% ± 1	0.4% ± 1	1% ± 1	2% ± 1	5% ± 1
	❶							

L Accuracy:

100Hz	31.83KH	15.91KH	1591H	159.1H	15.91H	1.591H	159.1mH	1.591mH
	15.91KH	1591H	159.1H	15.91H	1.591H	159.1mH	1.591mH	159.1uH
	2% ± 1	1% ± 1	0.5% ± 1	0.2% ± 1	0.1% ± 1	0.2% ± 1	0.5% ± 1	1% ± 1
	❶							❶
120Hz	26.52KH	13.26KH	1326H	132.6H	13.26H	1.326H	132.6mH	1.326mH
	13.26KH	1326H	132.6H	13.26H	1.326H	132.6mH	1.326mH	132.6uH
	2% ± 1	1% ± 1	0.5% ± 1	0.2% ± 1	0.1% ± 1	0.2% ± 1	0.5% ± 1	1% ± 1
	❶							❶
1KHz	3.183KH	1.591KH	159.1H	15.91H	1.591H	159.1mH	15.91mH	159.1uH
	1.591KH	159.1H	15.91H	1.591H	159.1mH	15.91mH	159.1uH	15.91uH
	2% ± 1	1% ± 1	0.5% ± 1	0.2% ± 1	0.1% ± 1	0.2% ± 1	0.5% ± 1	1% ± 1
	❶							❶

10KHz	318.3H 159.1H	159.1H 15.91H	15.91H 1.591H	1.591H 159.1mH	159.1mH 15.91mH	15.91mH 1.591mH	1.591mH 15.91uH	15.91uH 1.591uH
	5% ± 1 ①	2% ± 1	0.5% ± 1	0.2% ± 1	0.1% ± 1	0.2% ± 1	0.5% ± 1	1% ± 1 ①
	31.83H 15.91H	15.91H 1.591H	1.591H 159.1mH	159.1mH 15.91mH	15.91mH 1.591mH	1.591mH 159.1uH	159.1uH 1.591uH	1.591uH 0.159uH
100KHz ①	NA	5% ± 1	2% ± 1	1% ± 1	0.4% ± 1	1% ± 1	2% ± 1	5% ± 1
200KHz	15.91H 7.957H	7.957H 795.7mH	795.7mH 79.57mH	79.57mH 7.957mH	7.957mH 795.7uH	795.7uH 79.57uH	79.57uH 0.795uH	0.795uH 0.079uH
	NA	5% ± 1	2% ± 1	1% ± 1	0.4% ± 1	1% ± 1	2% ± 1	5% ± 1

D Accuracy:

Freq. \ Zx	20M ~ 10M (Ω)	10M ~ 1M (Ω)	1M ~ 100K (Ω)	100K ~ 10K (Ω)	10K ~ 1K (Ω)	1K ~ 100 (Ω)	100 ~ 1 (Ω)	1 ~ 0.1 (Ω)
	100Hz	±0.020	±0.010	±0.005	±0.002	±0.002	±0.002	±0.005
120Hz	①							①
1KHz								
10KHz	±0.050 ①	±0.020						
100KHz 200KHz ①	NA	±0.050	±0.020	±0.010	±0.004	±0.010	±0.020	±0.050

θ Accuracy:

Freq. \ Zx	20M ~ 10M (Ω)	10M ~ 1M (Ω)	1M ~ 100K (Ω)	100K ~ 10K (Ω)	10K ~ 1K (Ω)	1K ~ 100 (Ω)	100 ~ 1 (Ω)	1 ~ 0.1 (Ω)
	100Hz	±1.046	±0.523	±0.261	±0.105	±0.105	±0.105	±0.261
120Hz	①							①
1KHz								
10KHz	±2.615 ①	±1.046						
100KHz 200KHz ①	NA	±2.615	±1.046	±0.409	±0.209	±0.409	±1.046	±2.615

Z Accuracy:

As shown in table 1.

C Accuracy:

$$|Z_x| = \frac{1}{2 \cdot \mathbf{p} \cdot f \cdot C_x}$$

C_{Ae} = Ae of C

f : Test Frequency (Hz)

C_x : Measured Capacitance Value (F)

$|Z_x|$: Measured Impedance Value (Ω)

Accuracy applies when D_x (measured D value) ≤ 0.1

When $D_x > 0.1$, multiply C_{Ae} by $\sqrt{1 + D_x^2}$

Example:

Test Condition:

Frequency : 1KHz

Level : 1Vrms

DUT : 100nF

Then

$$|Z_x| = \frac{1}{2 \cdot \mathbf{p} \cdot f \cdot C_x}$$

$$= \frac{1}{2 \cdot \mathbf{p} \cdot 10^3 \cdot 100 \cdot 10^{-9}} = 1590 \Omega$$

Refer to the accuracy table, get $C_{Ae} = \pm 0.1\%$

L Accuracy:

$$|Z_x| = 2 \cdot \mathbf{p} \cdot f \cdot L_x$$

L_{Ae} = Ae of L

f : Test Frequency (Hz)

L_x : Measured Inductance Value (H)

$|Z_x|$: Measured Impedance Value (Ω)

Accuracy applies when D_x (measured D value) ≤ 0.1

When $D_x > 0.1$, multiply L_{Ae} by $\sqrt{1 + D_x^2}$

Example:

Test Condition:

Frequency : 1KHz

Level : 1Vrms

DUT : 1mH

Then

$$|Z_x| = 2 \cdot \mathbf{p} \cdot f \cdot L_x$$

$$= 2 \cdot \mathbf{p} \cdot 10^3 \cdot 10^{-3} = 6.283 \Omega$$

Refer to the accuracy table, get $L_{Ae} = \pm 0.5\%$

ESR Accuracy:

$$ESR_{Ae} = \pm Xx \cdot \frac{Ae}{100} \quad Xx = 2 \cdot p \cdot f \cdot Lx = \frac{1}{2 \cdot p \cdot f \cdot Cx}$$

ESR_{Ae} = Ae of ESR

f : Test Frequency (Hz)

Xx : Measured Reactance Value (Ω)

Lx : Measured Inductance Value (H)

Cx : Measured Capacitance Value (F)

Accuracy applies when Dx (measured D value) ≤ 0.1

Example:

Test Condition:

Frequency : 1KHz

Level : 1Vrms

DUT : 100nF

Then

$$|Zx| = \frac{1}{2 \cdot p \cdot f \cdot Cx}$$

$$= \frac{1}{2 \cdot p \cdot 10^3 \cdot 100 \cdot 10^{-9}} = 1590 \Omega$$

Refer to the accuracy table, get

$C_{Ae} = \pm 0.1\%$,

$$ESR_{Ae} = \pm Xx \cdot \frac{Ae}{100} = \pm 1.59 \Omega$$

D Accuracy:

$$D_{Ae} = \pm \frac{Ae}{100}$$

D_{Ae} = Ae of D measurement value

Accuracy applies when Dx (measured D value) ≤ 0.1

When Dx > 0.1, multiply Dx by (1+Dx)

Example:

Test Condition:

Frequency : 1KHz

Level : 1Vrms

DUT : 100nF

Then

$$|Zx| = \frac{1}{2 \cdot p \cdot f \cdot Cx}$$

$$= \frac{1}{2 \cdot p \cdot 10^3 \cdot 100 \cdot 10^{-9}} = 1590 \Omega$$

Refer to the accuracy table, get

$C_{Ae} = \pm 0.1\%$,

$$D_{Ae} = \pm \cdot \frac{Ae}{100} = \pm 0.002$$

Q Accuracy:

$$Q_{Ae} = \pm \frac{Q_x^2 \cdot De}{1 \mp Q_x \cdot De}$$

Q_{Ae} = Ae of Q measurement value

Q_x : Measured Quality Factor Value

De : Relative D Accuracy

Accuracy applies when $Q_x \cdot De < 1$

Example:

Test Condition:

Frequency : 1KHz

Level : 1Vrms

DUT : 1mH

Then

$$\begin{aligned} |Z_x| &= 2 \cdot p \cdot f \cdot L_x \\ &= 2 \cdot p \cdot 10^3 \cdot 10^{-3} = 6.283 \Omega \end{aligned}$$

Refer to the accuracy table, get

$L_{Ae} = \pm 0.5\%$,

$$De = \pm \frac{Ae}{100} = \pm 0.005$$

If measured $Q_x = 20$

Then

$$\begin{aligned} Q_{Ae} &= \pm \frac{Q_x^2 \cdot De}{1 \mp Q_x \cdot De} \\ &= \pm \frac{2}{1 \mp 0.1} \end{aligned}$$

? Accuracy:

$$q_{Ae} = \frac{180}{p} \cdot \frac{Ae}{100}$$

Example:

Test Condition:

Frequency : 1KHz

Level : 1Vrms

DUT : 100nF

Then

$$\begin{aligned} |Z_x| &= \frac{1}{2 \cdot p \cdot f \cdot C_x} \\ &= \frac{1}{2 \cdot p \cdot 10^3 \cdot 100 \cdot 10^{-9}} = 1590 \Omega \end{aligned}$$

Refer to the accuracy table, get

$Z_{Ae} = \pm 0.1\%$,

$$\begin{aligned} q_{Ae} &= \pm \frac{180}{p} \cdot \frac{Ae}{100} \\ &= \pm \frac{180}{p} \cdot \frac{0.1}{100} = \pm 0.057 \text{ deg} \end{aligned}$$

- Testing Signal:
 - Level Accuracy : $\pm 10\%$
 - Frequency Accuracy : 0.1%
- Output Impedance : $100\Omega \pm 5\%$
- General:
 - Temperature : 0°C to 70°C (Operating)
 -20°C to 70°C (Storage)
 - Relative Humidity : Up to 85%
 - AC Power : $110/220\text{V}$, $60/50\text{Hz}$
 - Dimensions : $300\text{mm} \times 220\text{mm} \times 150\text{mm}$ (L x W x H) $11.8'' \times 8.7'' \times 5.9''$
 - Weight : 4500g

Considerations

When LCR measurement mode is selected, the following factors shall be considered.

Test Frequency The test frequency is user selectable and can be changed. Generally, a 1 KHz test signal or higher is used to measure capacitors that are $0.01\mu\text{F}$ or smaller and a 120Hz test signal is used for capacitors that are $10\mu\text{F}$ or larger. Typically a 1 KHz test signal or higher is used to measure inductors that are used in audio and RF (radio frequency) circuits. This is because these kinds of inductors operate at higher frequencies and require that they shall be measured at a higher frequency. Generally, inductors with inductances below 2mH should be measured at test frequency of 1 KHz or higher and inductors above 200H should be measured at 120Hz or lower.

It is best to check with the component manufacturers' data sheet to determine the best test frequency for the device.

Charged Capacitors Always discharge any capacitor prior to making a measurement since a charged capacitor may seriously damage the meter.

Effect Of High D on Accuracy A low D (Dissipation Factor) reading is desirable. Electrolytic capacitors inherently have a higher dissipation factor due to their normally high internal leakage characteristics. If the D (Dissipation Factor) is excessive, the capacitance measurement accuracy may be degraded.

It is best to check with the component manufacturers' data sheet to determine the desirable D value of a good component.

Measuring Capacitance of Cables, Switches or Other Parts Measuring the capacitance of coaxial cables is very useful in determining the actual length of the cable. Most manufacturer specifications list the amount of capacitance per foot of cable and therefore the length of the cable can be determined by measuring the capacitance of that cable.

For example: A manufacturers, specification calls out a certain cable, to have a capacitance of 10 pF per foot, After measuring the cable, a capacitance reading of 1.000nF is displayed. Dividing 1000pF (1.000 nF) by 10 pF per foot yields the length of the cable to be approximately 100 feet.

Even if the manufacturers' specification is not known, the capacitance of a measured length of cable (such as 10 feet) can be used to determine the capacitance per foot. Do not use too short length such as one foot, because any error becomes magnified in the total length calculations.

Sometimes, the affecting stray capacitance of switches, interconnect cables, circuit board foils, or other parts, could be critical to circuit design, or must be repeatable from one unit to another.

Series Vs Parallel Measurement (for Inductors) The series mode displays the more accurate measurement in most cases. The series equivalent mode is essential for obtaining an accurate Q reading of low Q inductors. Where ohmic losses are most significant, the series equivalent mode is preferred. However, there are cases

where the parallel equivalent mode may be more appropriate. For iron core inductors operating at higher frequencies where hysteresis and eddy currents become significant, measurement in the parallel equivalent mode is preferred.

1.4 Accessories

- Operating Manual 1 pc
- AC Power Cord 1 pc
- Kelvin Clip 1 pc
- DMM Test Leads 1 pc

2. Operation

2.1 Physical Description

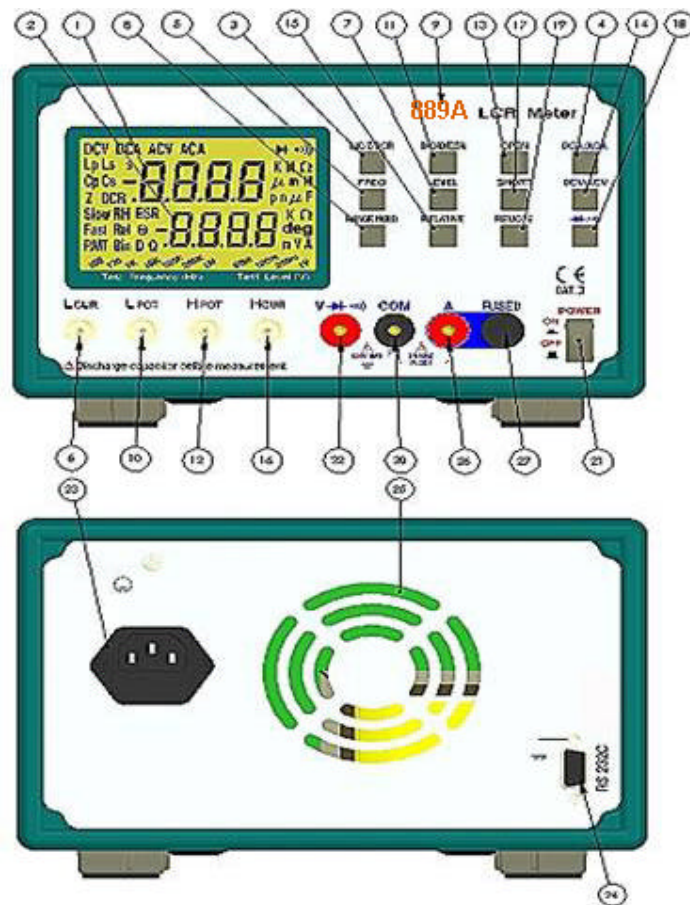

- | | |
|------------------------------|-----------------------------------|
| 1. Primary Parameter Display | 2. Secondary Parameter Display |
| 3. L/C/Z/DCR Function Key | 4. DCA/ACA Function Key |
| 5. Measurement Frequency Key | 6. LCUR Terminal |
| 7. Measurement Level Key | 8. Range Hold Key |
| 9. Model Number | 10. LPOT Terminal |
| 11. D/Q/?/ESR Function Key | 12. HPOT Terminal |
| 13. Open Calibration Key | 14. DCV/ACV Function Key |
| 15. Relative Key | 16. HCUR Terminal |
| 17. Short Calibration Key | 18. Diode/Continuity Function Key |
| 19. Remote Function Key | 20. COM Terminal |
| 21. Power Switch | 22. V/Diode/Continuity Terminal |
| 23. AC Power | 24. RS-232 Port |
| 25. Exhaust Perforation | 26. A Terminal |
| 27. 2A Fuse | |

2.2 Making Measurement

2.2.1 Open and Short Calibration

The 889A provides open/short calibration capability so the user can get better accuracy in measuring high and low impedance. We recommend that the user perform open/short calibration if the test level or frequency has been changed.

- Open Calibration

First, remaining the measurement terminals at the open status, press the **Open** key then the LCD will display:



This calibration takes about 15 seconds. After it is finished, the 889A will beep to show that the calibration is done.

- Short Calibration

To perform the short calibration, insert the Shorting Bar into the measurement terminals. Press the **Short** key then the LCD will display:



This calibration takes about 15 seconds. After it is finished, the 889A will beep to show that the calibration is done.

2.2.2 Relative Mode

The relative mode lets the user to make a quick sort of a bunch of components. First, insert the standard value component to get the standard value reading. (Approximately 5 seconds to get a stable reading.) Then, press the **Relative** key, the primary display will reset to zero. Remove the standard value component and insert the unknown component, the LCD will show the value that is the difference between the standard value and unknown value.

2.2.3 Range Hold

To set the range hold, insert a standard component in that measurement range. (Approximately 5 seconds to get a stable reading.) Then, by pressing the **Range Hold** key it will hold the range within 0.5 to 2 times of the current measurement range. When the **Range Hold** is pressed, the LCD will display:



2.2.4 DC Resistance Measurement

The DC resistance measurement measures the resistance of an unknown component by 1VDC. Press the **L/C/Z/DCR** key to select the DCR measurement. The LCD will display:

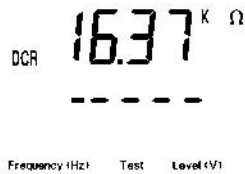

2.2.5 AC Impedance Measurement

The AC impedance measurement measures the Z of an unknown device. Press the **L/C/Z/DCR** key to select the Z measurement. The LCD will display:

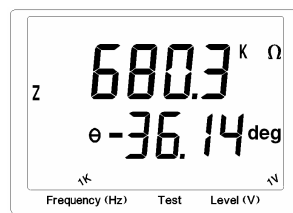

The testing level and frequency can be selected by pressing the **Level** key and **Freq** key, respectively.

2.2.6 Capacitance Measurement

To measure the capacitance of a component, users may be able to press the **L/C/Z/DCR** key to select either Cs (Serial Mode) or Cp (Parallel Mode) measurement mode. If the serial mode (Cs) is selected, the D, Q and ESR can be shown on the secondary display. If the parallel mode (Cp) is selected, only the D and Q can be shown on the secondary display. The following shows some examples of capacitance measurement:

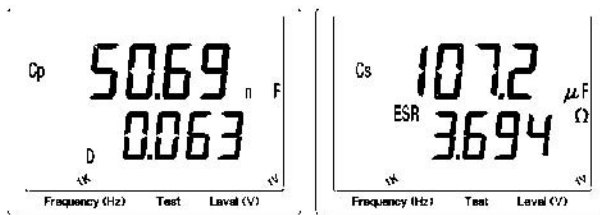

The testing level and frequency can be selected by pressing the **Level** key and **Freq** key, respectively.

2.2.7 Inductance Measurement

Press the **L/C/Z/DCR** key to select Ls or Lp mode for measuring the inductance in serial mode or parallel mode. If the serial mode (Ls) is selected, the D, Q and ESR can be shown on the secondary display. If the parallel mode (Lp) is selected, only the D and Q can be shown on the secondary display. The following shows some examples of inductance measurement:

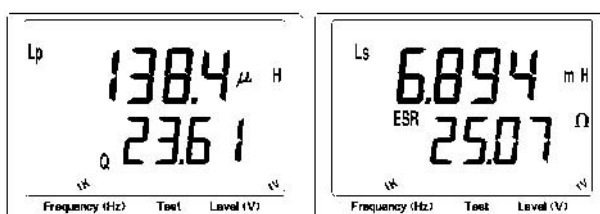

The testing level and frequency can be selected by pressing the **Level** key and **Freq** key, respectively.

3. Operation Modes

There are four operation modes in the 889A. They are **Normal**, **Binning**, **Remote** and **Remote Binning** modes. By pressing the **Remote** button, users can select one of the 4 operation modes above.

- **Normal Mode:**

The **Normal** mode is the default operation mode when power on. It is a local mode that the 889A is controlled by the keypads and the results of the measurement will be sent to both LCD display and a remote RS-232 equipped PC through the build-in RS-232 port.

- **Binning Mode:**

The **Binning** mode is reserved for future use (such as GPIB). Currently, it is set to work the same way as the **Normal** mode that receives commands from the keypads and sends the results of measurement to both LCD display and a remote PC through the RS-232 port.

- **Remote Binning Mode:**

In the **Remote Binning** mode, the “RMT Bin” on the LCD will be lit, the operation of 889A is controlled by a remote RS-232 equipped PC or terminal, and the results of the measurement will be simultaneously sent to the local LCD display and remote workstation through the RS-232 port.

In this mode all functional **keypads** except **Remote** button are locked.

Remote Binning mode is opened for users to design your own private, fast and high efficient application programs. Users can design a server or driver (any software component that can do server's job) with **Graphic** interface, **OSI** network model, and powerful interpreter built in it to support Graphic display, Network connectivity, structure command (**SCPI**, **IEEE488** etc.) interpretations, and let it be a bridge between a higher level application program such as **VB**, **VISUAL C++**, **EXCEL**, **ACCESS** etc. and the 889A. It is described in the following figure.

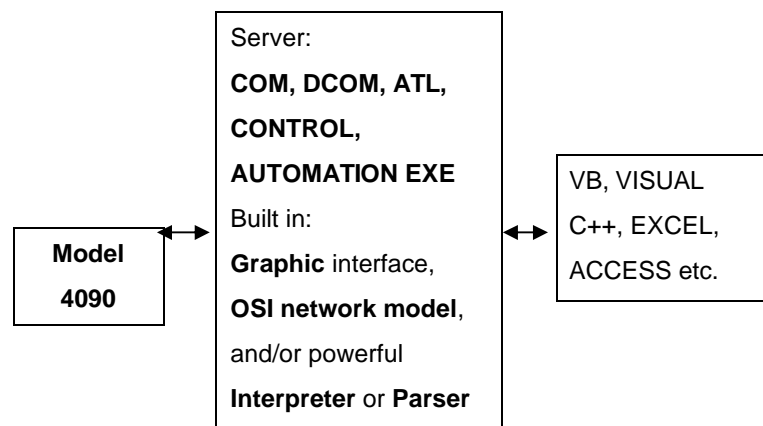

The communication protocol between the 889A and a remote RS-232 equipped PC is described as follows.

1. The commands that will be sent from a remote PC to the 889A are used to set-up the machine to a selected measurement mode.

The command syntax is:

MOD current-state-code

It always starts with **MOD** follows by a space and then the **current state code**. The **current state code** that is defined in the table below is 3 bytes (24 bits) long, bit-23, 22, 21... bit-0, where bit-23 is the MSB and bit-0 is the LSB.

bit position	LCR	DC/AC V/A
Bit 2 – Bit 0	(test freq)	Reserved
000	100 Hz	
001	120 Hz	
010	1K Hz	
011	10K Hz	
100	100K Hz	
101	200K Hz	
110	Reserved	
111	Reserved	
Bit 4 – Bit 3	(test level)	Reserved
00	50 mVrms	
01	250 mVrms	
10	1 Vrms	
11	Reserved	
Bit 5	Reserved	
0	Default	Default
1	Reserved	Reserved
Bit 6		
0	Relative	Relative
1	Normal	Normal
Bit 7		
0	Calibration	Calibration
1	Normal	Normal
Bit 10 – Bit 8		Reserved
000	Lp	
001	Ls	
010	Cp	
011	Cs	
100	Z	
101	DCR	
110	Reserved	
111	Reserved	
Bit 12 – Bit 11		Reserved
00	D	
01	Q	
10	DEG	
11	ESR	
Bit 16 – Bit 13		
0000	RH nH	Reserved
0001	RH uH	RH mV, mA
0010	RH mH	RH V, A
0011	RH H	Reserved
0100	RH pF	
0101	RH nF	
0110	RH uF	
0111	RH mF	
1000	RH F	
1001	RH Ohm	
1010	RH K-Ohm	
1011	RH M-Ohm	
1100	Reserved	

1101		
1110		
1111	Auto-Ranging	Auto-Ranging
Bit 17		
0	Short Cal	Short Cal
1	Open Cal	Reserved
Bit 21 – Bit 18	Measurement Modes	
0000	Reserved	
0001	LCR	
0010	DCV	
0011	ACV	
0100	Diode	
0101	Continuity	
0110	DCA	
0111	ACA	
Others	Reserved	
Bit 23 – Bit 22	Reserved	
00		
01		
10		
11		

For example: if LCR function, Cp with D measurement mode is selected in Auto-ranging with Relative and Open/Short Calibration are turned off and test signal is 1 Vrms in 1 KHz, then the command is as following:

MOD 000001111110001011010010

- The results of the measurement that will be sent from the 889A to a remote PC will be packed in either 7-byte or 11-byte format.

When dual data (such as Cp with D) will be sent, the data is packed in 11-byte format shown as following:

Lead_code1 : 02

Lead_code2 : 09

Data_code : 8-byte long; two 32-bit floating point number format; the first 4-byte is the main reading (Cp) and the second 4-byte is the secondary reading (D)

Checksum : -((02+09+data_code) && 0x00FF)

02	09	M-B0	M-B1	M-B2	M-B3	S-B0	S-B1	S-B2	S-B3	CS
----	----	------	------	------	------	------	------	------	------	----

where M-Bx and S-Bx are the four bytes floating point format of main and secondary reading which is sent from the lowest byte first.

When only main reading (such as DCR) will be sent, the data is packed in 7-byte format described below:

Lead_code1 : 02

Lead_code2 : 03

Data_code : 4 bytes long; the 32-bit floating point format of the main reading

Checksum : -((02+03+data_code) && 0x00FF)

02	03	M-B0	M-B1	M-B2	M-B3	CS
----	----	------	------	------	------	----

When only secondary reading (such as DCV) will be sent, the data is packed in 11-byte format described below:

Lead_code1 : 02

Lead_code2 : 09

Data_code : 8 bytes long; two 32-bit floating point format of the secondary reading
Checksum : -((02+09+data_code) && 0x00FF)

02	09	S-B0	S-B1	S-B2	S-B3	S-B0	S-B1	S-B2	S-B3	CS
----	----	------	------	------	------	------	------	------	------	----

● Remote Mode:

When in the **Remote** mode, the “RMT” on the LCD will be lit and the 889A is capable of communicating to remote RS-232 equipped PC or terminal through the build-in RS-232 port. The connection setting is as follow:

Transmission Mode : Half Duplex
Baud Rate : 9600
Parity Bit : None
Data Bits : 8
Stop Bit : 1
Handshake : None

In this mode, the LCD display and all keypads except the **Remote** button will be locked. And the external program through the RS-232 port controls the operation of the 889A.

3.1 Remote Mode Command Syntax

The command syntax of Models 4090 is as following:

COMMAND(?) (PARAMETER)

The format of COMMAND and PARAMETER is as following:

1. There is at least one space between COMMAND and PARAMETER.
2. The PARAMETER should use only ASCII string not numerical code.
3. Value parameter can be integer, floating or exponent with the unit. For example:

50mV
0.05V
5.0e1mV

4. The question mark (?) at the end of COMMAND means a query or a measuring command. For example:

“CpD” sets the measurement mode to Cp and D.

“CpD?” sets the measurement mode to Cp and D as well as measures the values and send them back.

5. The COMMAND and PARAMETER can be either upper or lower case. But the unit to describe the value in the PARAMETER should have different between milli (m) and mega (M). For example:

1mV equals 0.001V.
1MV equals 1000000V.

6. The “end of command” character should be placed at the end. There are:

ASCII CR (0DH) or
ASCII LF (0AH)

3.2 Remote Mode Commands

Measurement Setting (or Querying) Command

The following measurement mode-setting and the query commands are supported in the 889A. When a mode-setting command is entered the 889A will return “OK” after setting is complete. When query command is entered, the 889A will send back the values of measurement.

- **DCR(?)** DC resistance measurement mode setting or querying command.
- **CpRp(?)** Parallel capacitance and parallel resistance measurement mode setting or querying command.
- **CpQ(?)** Parallel capacitance and quality factor measurement mode setting or querying command.
- **CpD(?)** Parallel capacitance and dissipation factor measurement mode setting or querying command.

- **CsRs(?)** Serial capacitance and serial resistance measurement mode setting or querying command.
- **CsQ(?)** Serial capacitance and quality factor measurement mode setting or querying command.
- **CsD(?)** Serial capacitance and dissipation factor measurement mode setting or querying command.
- **LpRp(?)** Parallel inductance and parallel resistance measurement mode setting or querying command.
- **LpQ(?)** Parallel inductance and quality factor measurement mode setting or querying command.
- **LpD(?)** Parallel inductance and dissipation factor measurement mode setting or querying command.
- **LsRs(?)** Serial inductance and serial resistance measurement mode setting or querying command.
- **LsQ(?)** Serial inductance and quality factor measurement mode setting or querying command.
- **LsD(?)** Serial inductance and dissipation factor measurement mode setting or querying command.
- **RsXs(?)** Serial resistance and serial reactance measurement mode setting or querying command.
- **RpXp(?)** Parallel resistance and parallel reactance measurement mode setting or querying command.
- **ZTD(?)** Impedance and angle (Deg) measurement mode setting or querying command.
- **ZTR(?)** Impedance and angle (Rad) measurement mode setting or querying command.
- **DCV(?)** DC Voltage measurement mode setting or query command.
- **ACV(?)** AC Voltage measurement mode setting or query command.
- **DCA(?)** DC Current measurement mode setting or query command.
- **ACA(?)** AC Current measurement mode setting or query command.

Example:

CPD (*set to Cp-D measurement mode*)

OK

CPD?

0.22724 0.12840 (*return values*)

DCR?

5.1029 (*return value*)

***IDN?**

Query the identity of the 889A. This command is used to identify the basic information of 889A. The return value has four fields separated by comma (.). The total length will not greater than 100 characters. The four fields are:

1. Manufacturer Name
2. Model Number
3. Serial Number
4. Firmware Version Number

Example:

*IDN?

B&K PRECISION CORP. MODEL4090,123456789,4.096

***RST**

Reset the 889A to the power on default status. The default status is:

1KHz 1Vrms CpD uF

After the 889A is reset, it will return the identity string back.

ASC

Set the format of the return value. This command sets the ASCII string return or the numerical code.

PARAMETER:

ON ASCII string

OFF Numerical code

Example:

```
ASC ON
OK      (return)
FREQ?
1KHz   (return)

ASC OFF
OK      (return)
FREQ?
2      (return)
```

CORR OPEN

Perform the open calibration. This command sets the 889A to do the open calibration. After the calibration is done, the 889A will return the "OK" string back.

CORR SHORT

Perform the short calibration. This command sets the 889A to do the short calibration. After the calibration is done, the 889A will return the "OK" string back.

FREQ(?) PARAMETER

Set (query) the measurement frequency.

● **FREQ PARAMETER**

Set the measurement frequency according to the parameter. When setting command is entered, the 889A will return "OK" string after setting is done.

PARAMETER:

ASCII string	Numerical code
100Hz	0
120Hz	1
1KHz	2
10KHz	3
100KHz	4
200KHz	5

Example:

```
FREQ 100KHz
OK (return)
```

● **FREQ?**

Return the current measurement frequency setting.

Example:

```
ASC ON
OK
FREQ?
1KHz (return value)

ASC OFF
OK
FREQ?
2 (return value)
```

LEV(?) PARAMETER

Set (query) the measurement level.

● **LEV PARAMETER**

Set the measurement level according to the parameter. When setting is done the 889A will return "OK" string.
PARAMETER:

ASCII string	Numerical code
1VDC	0
1Vrms	1
250mVrms	2
50mVrms	3

Example:

```
LEV 1V
OK
```

● **LEV?**

Return the current measurement level setting.

Example:

```
ASC ON
OK
LEV?
1Vrms (return value)

ASC OFF
OK
LEV?
1 (return value)
```

MODE?

Query the measurement mode. If in LCR measurement mode, six fields will be returned.

1. Frequency
2. Level
3. Measurement mode
4. Unit of primary display
5. Unit of secondary display

The existence of field 5 depends on the measurement mode. For example, there's no field 5 if the measurement mode is DCR. The separation between fields is space (ASCII 20H).

Example:

```
ASC ON
OK
CPD
OK
MODE?
1KHz 1Vrms CpD uF (return value)

ASC ON
OK
CPRP
OK
MODE?
1KHz 1Vrms CpRp uF Ohm (return value)
```

If in Voltage measurement mode, three fields will be returned.

1. Measurement mode
2. Unit of primary display

Example:

```
ASC ON
OK
DCV
OK
MODE?
DCV V      (return value)

RANG mV
OK
MODE?
DCV mV     (return value)
```

RANG(?) PARAMETER

Set (query) the measurement unit.

● **RANG PARAMETER**

Set the measurement unit according to the parameter. "OK" string will be returned when setting is complete.

PARAMETER:

ASCII string	Numerical code
pF	0
nF	1
uF	2
mF	3
F	4
nH	8
uH	9
mH	10
H	11
KH	12
mOhm	17
Ohm	18
KOhm	19
MOhm	20
mV	21
V	22
mA	23
A	24

Example:

```
RANG pF
OK
```

● **RANG?**

Return the current measurement unit setting.

Example:

```
ASC ON
OK
RANG?
pF (return value)
```

ASC OFF

OK

RANG?

0 (*return value*)

READ?

Return the measurement value. This command will perform a measurement according to the current measurement mode and return the measured value.

Example:

CPD

OK

READ?

0.22724 0.12840 (*return value*)

DCR

OK

READ?

5.1029 (*return value*)

The "DCR", "DCV", and "ACV" measurements will send only one measured value. The other measurement modes will send two measured values separated by space (ASCII 20H).

4. Application

4.1 Test Leads Connection

Auto balancing bridge has four terminals (H_{CUR} , H_{POT} , L_{CUR} and L_{POT}) to connect to the **device under test (DUT)**. It is important to understand what connection method will affect the measurement accuracy.

- 2-Terminal (2T)

2-Terminal is the easiest way to connect the DUT, but it contains many errors that are the inductance and resistance as well as the parasitic capacitance of the test leads (Figure 4.1). Due to these errors in measurement, the effective impedance measurement range will be limited at 100Ω to $10K\Omega$.

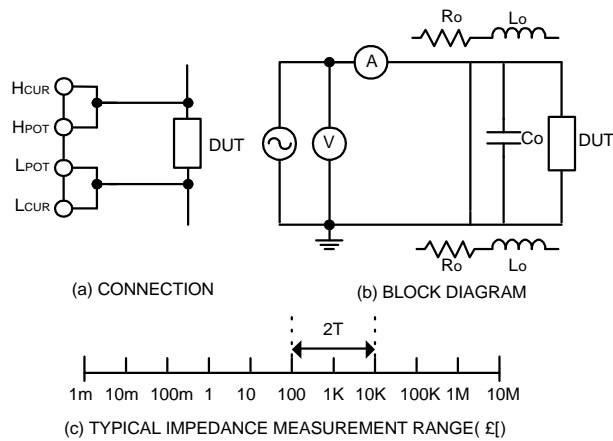

Figure 4.1

- 3-Terminal (3T)

3-Terminal uses coaxial cable to reduce the effect of the parasitic capacitor (Figure 4.2). The shield of the coaxial cable should connect to guard of the instrument to increase the measurement range up to $10M\Omega$.

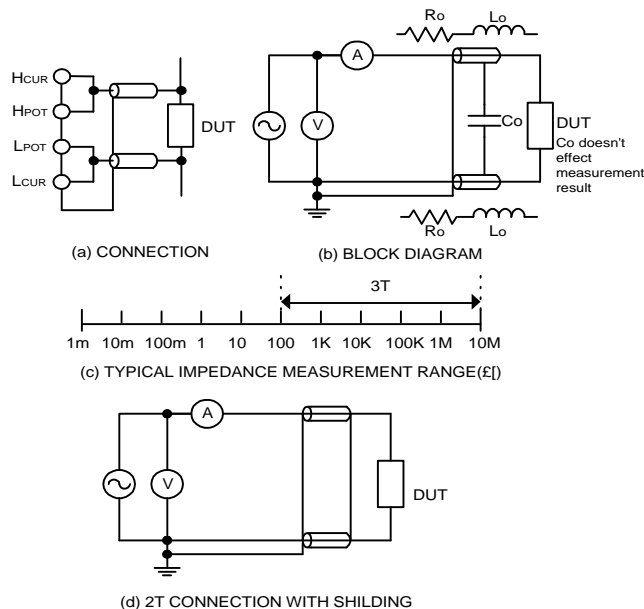

Figure 4.2

- 4-Terminal (4T)

4-Terminal connection reduces the effect of the test lead resistance (Figure 4.3). This connection can improve the measurement range down to $10m\Omega$. However, the effect of the test lead inductance can't be eliminated.

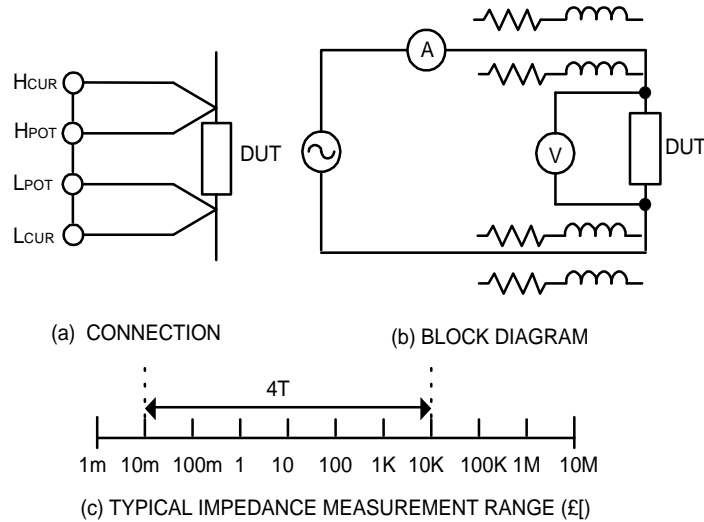

Figure 4.3

● 5-Terminal (5T)

5-Terminal connection is the combination of 3T and 4T (Figure 4.4). It has four coaxial cables. Due to the advantage of the 3T and 4T, this connection can widely increase the measurement range for 10mΩ to 10MΩ.

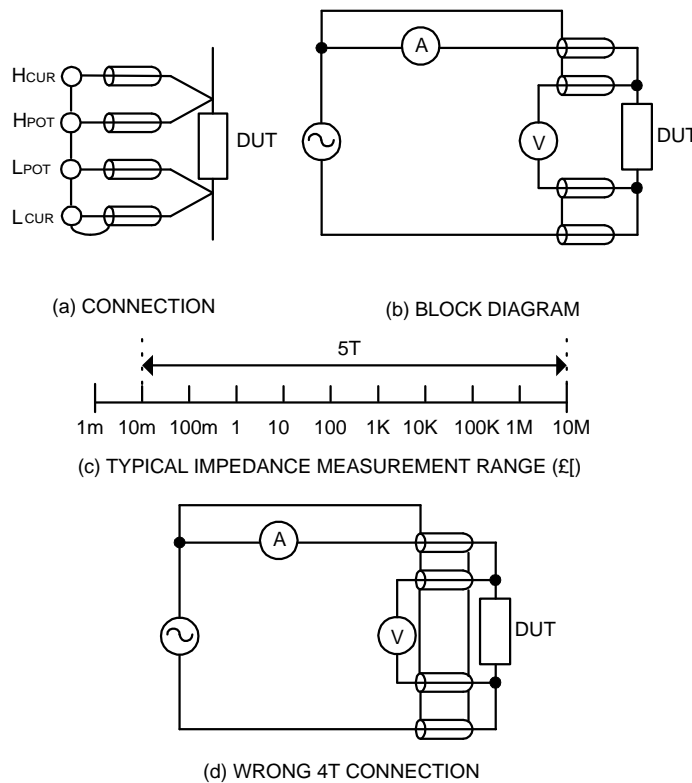

Figure 4.4

● 4-Terminal Path (4TP)

4-Terminal Path connection solves the problem that caused by the test lead inductance. 4TP uses four coaxial cables to isolate the current path and the voltage sense cable (Figure 4.5). The return current will flow through the coaxial cable as well as the shield. Therefore, the magnetic flux that generated by internal conductor will cancel out the magnetic flux generated by external conductor (shield). The 4TP connection increases the measurement range from 1mΩ to 10MΩ.

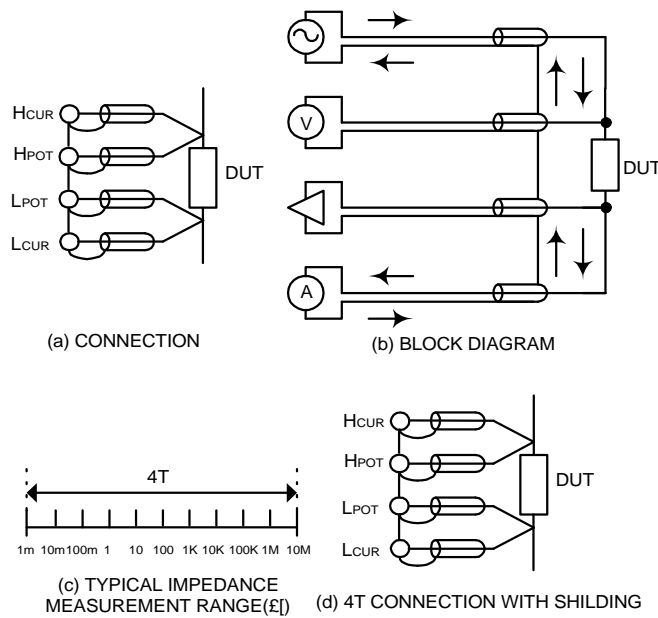

Figure 4.5

● Eliminating the Effect of the Parasitic Capacitor

When measuring the high impedance component (i.e. low capacitor), the parasitic capacitor becomes an important issue (Figure 4.6). In figure 4.6(a), the parasitic capacitor C_d is paralleled to DUT as well as the C_i and C_h . To correct this problem, add a guard plane (Figure 4.6(b)) in between H and L terminals to break the C_d . If the guard plane is connected to instrument guard, the effect of C_i and C_h will be removed.

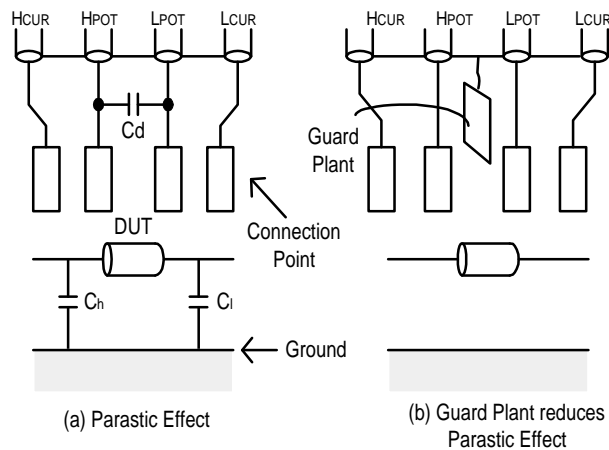

Figure 4.6

4.2 Open/Short Compensation

For those precision impedance-measuring instruments, the open and short compensation need to be used to reduce the parasitic effect of the test fixture. The parasitic effect of the test fixture can be treated like the simple passive components in figure 4.7(a). When the DUT is open, the instrument gets the conductance $Y_p = G_p + j\omega C_p$ (Figure 4.7(b)). When the DUT is short, the instrument gets the impedance $Z_s = R_s + j\omega L_s$ (Figure 4.7(c)). After the open and short compensation, the 889A has Y_p and Z_s that can then be used for the real Z_{dut} calculation (Figure 4.7(d)).

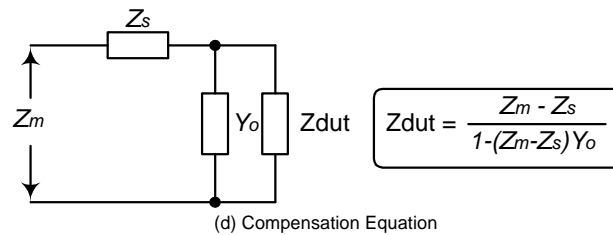
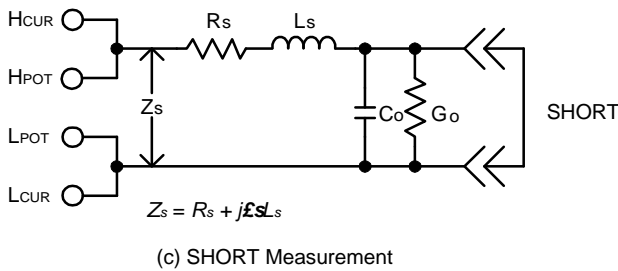
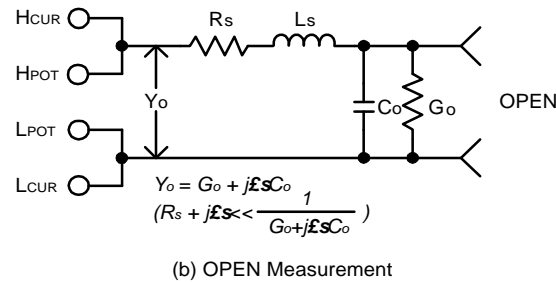
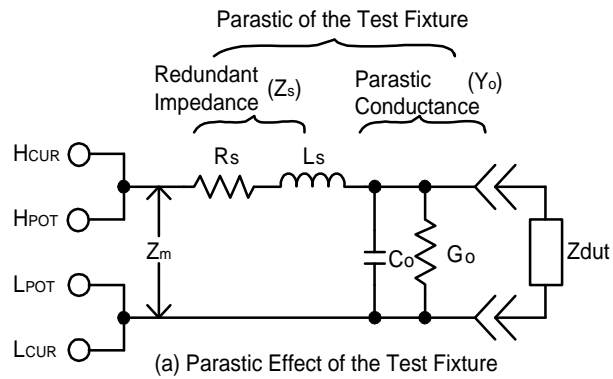

Figure 4.7

4.3 Selecting the Series or Parallel Mode

According to different measuring requirement, there are series and parallel modes to describe the measurement results. It is depending on the high or low impedance value to decide what mode to be used.

- Capacitor

The impedance and capacitance in the capacitor are negatively proportional. Therefore, the larger capacitance means the lower impedance, the smaller capacitance means the higher impedance. Figure 4.8 shows the equivalent circuit of capacitor. If the capacitance is small, the Rp is more important than the Rs. If the capacitance is large, the Rs shouldn't be avoided. Hence, it is properly to use parallel mode for low capacitance measurement and series mode for high capacitance measurement.

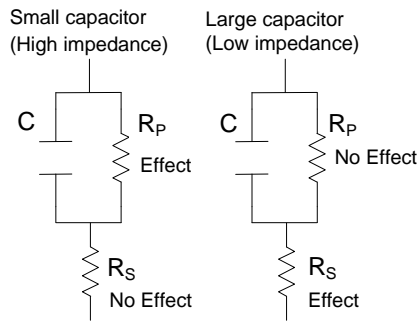

- Inductor

The impedance and inductance of an inductor are positively proportional when test frequency is fixed. Therefore, the larger inductance equals to higher impedance and vice versa. Figure 4.9 shows the equivalent circuit of inductor. When the inductance is small, the R_S becomes more important than the R_P . When the inductance is large, the R_P should be taken into consideration. Therefore, it is properly using series mode to measure an inductor with low inductance and parallel mode to measure an inductor with high inductance.

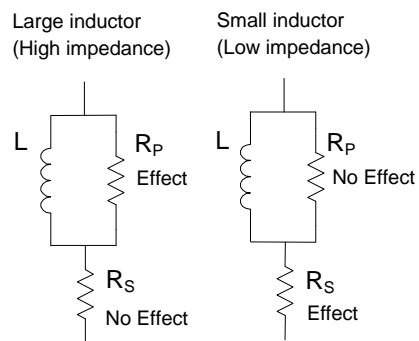

Figure 4.9

5. Limited ONE-Year Warranty

Limited One-Year Warranty

B&K Precision Corp. warrants to the original purchaser that its product and the component parts thereof, will be free from defects in workmanship and materials for a period of one year from the date of purchase.

B&K Precision Corp. will, without charge, repair or replace, at its' option, defective product or component parts. Returned product must be accompanied by proof of the purchase date in the form a sales receipt.

To obtain warranty coverage in the U.S.A., this product must be registered by completing and mailing the enclosed warranty card to B&K Precision Corp., 22820 Savi Ranch Parkway, Yorba Linda, CA 92887 within fifteen (15) days from proof of purchase.

Exclusions: This warranty does not apply in the event of misuse or abuse of the product or as a result of unauthorized alterations or repairs. It is void if the serial number is alternated, defaced or removed.

B&K Precision Corp. shall not be liable for any consequential damages, including without limitation damages resulting from loss of use. Some states do not allow limitation of incidental or consequential damages, so the above limitation or exclusion may not apply to you.

This warranty gives you specific rights and you may have other rights, which vary from state-to-state.

Model Number: _____

Date Purchased: _____

22820 Savi Ranch Parkway
Yorba Linda, CA 92887
714.921.9095
714.921.6422 Facsimile

Service Information

Warranty Service: Please return the product in the original packaging with proof of purchase to the below address. Clearly state in writing the performance problem and return any leads, connectors and accessories that you are using with the device.

Non-Warranty Service: Return the product in the original packaging to the below address. Clearly state in writing the performance problem and return any leads, connectors and accessories that you are using with the device. Customers not on open account must include payment in the form of a money order or credit card. For the most current repair charges contact the factory before shipping the product.

Return all merchandise to B&K Precision Corp. with pre-paid shipping. The flat-rate repair charge includes return shipping to locations in North America. For overnight shipments and non-North America shipping fees contact B&K Precision Corp..

B&K Precision Corp.
22820 Savi Ranch Parkway
Yorba Linda, CA 92887
Phone: 714- 921-9095
Facsimile: 714-921-6422
Email: service@bkprecision.com

Include with the instrument your complete return shipping address, contact name, phone number and description of problem.

6. Safety Precaution

SAFETY CONSIDERATIONS

The Models 4090 LCR Meter has been designed and tested according to Class 1A 1B or 2 according to IEC479-1 and IEC 721-3-3, Safety requirement for Electronic Measuring Apparatus.

SAFETY PRECAUTIONS/SAFETY NOTES

The following general safety precautions must be observed during all phases of operation, service, and repair of this instrument. Failure to comply with these precautions or with specific warnings elsewhere in this manual violates safety standards of design, manufacture, and intended use of the instrument.

The manufacturer assumes no liability for the customer's failure to comply with these requirements.

BEFORE APPLYING POWER

Verify that the product is set to match the available line voltage is installed.

SAFETY SYMBOLS



Caution, risk of electric shock



Earth ground symbol



Equipment protected throughout by double insulation or reinforced insulation



Caution (refer to accompanying documents)

DO NOT SUBSTITUTE PARTS OR MODIFY INSTRUMENT

Because of the danger of introducing additional hazards, do not install substitute parts or perform any unauthorized modification to the instrument. Return the instrument to a qualified dealer for service and repair to ensure that safety features are maintained.

INSTRUMENTS WHICH APPEAR DAMAGED OR DEFECTIVE SHOULD NOT BE USED! PLEASE CONTACT B&K PRECISION CORP. INCORPORATED FOR INFORMATION ON REPAIRS.