

Models 6010, 6011, 6012 & 6013

Highspeed Programmable Attenuators

Data Sheet



Highspeed Programmable Attenuators for wireless communications applications

Models 6010, 6011, 6012 & 6013

The 6010 series represents a new concept of programmable RF and microwave attenuators offering performance and features not found in traditional attenuators. The attenuators can operate in an attenuation range of 80dB, minimum step size of 0.05 dB, switching speed of up to 2 μ s and cover a wide frequency range of 1.5 – 13.5 GHz. Attenuation values can be set manually from the front panel, programmed via the standard GPIB or RS232 interface or created with the included Windows based software by generating an attenuation profile and transferring it to the instrument's internal memory. The outstanding performance, flexibility and ease of use of the 6010 series make them an ideal tool for many applications in the field of wireless communications such as CDMA, GSM, wireless LAN, Bluetooth, ETC (Electronic Toll Collection) and RFID.

Applications

- Simulation of handover/handoff scenarios
- Simulation of fading scenarios and path degradation due to obstacles
- Receiver sensitivity test (verification of automatic gain control)

Features

- Four models cover a wide range of frequencies:

Model	Frequency Range
6010	1.5 to 4.5GHz
6011	3.0 to 9.0GHz
6012	4.5 to 13.5GHz
6013	1.95 to 5.85GHz

- PC Software for creation of arbitrary attenuation profiles and download to the attenuator's internal program memory (included)
- Program mode operation offering:
 - 128k word built-in program memory suitable for simulation of complex air interface scenarios
 - Clock frequency of up to 0.5MHz providing attenuator switching in minimum steps of 2 μ s
 - Flexible program execution in FREE, BURST or GATE mode
 - Setting of Pause time in number of clock cycles or absolute time
- 80dB attenuation range (all 4 models)
- Minimum step size of 0.05dB
- Programmable via standard GPIB/IEEE-488 and RS232 interfaces

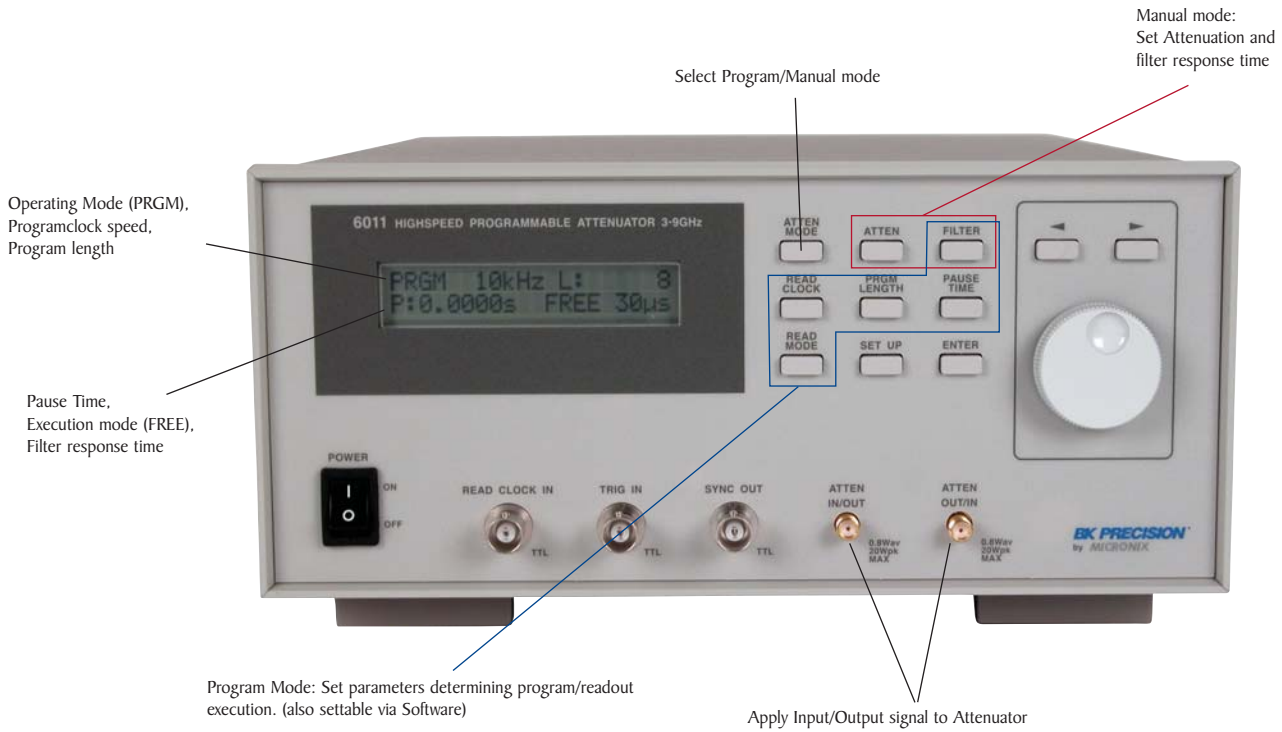

Flexible operating modes

The 6010 series offers several ways to create and output attenuation data. Attenuation levels can be set manually using the front panel keys or by executing a program resident in internal memory.

Manual mode

Use the rotary encoder to set the attenuation level and filter response time. Alternatively, you can also set the attenuation level by sending a remote command via RS-232C or GPIB interface.

```
MANUAL    23.45 dB
           30 μs
```

Program mode

In this mode, attenuation levels are controlled by the attenuation profile resident in program memory. The 5 parameters Readout Clock, Program Length, Pause Time, Readout Mode and Filter Setting control the execution of the attenuation program.

```
PRGM    10kHz L: 131072
P: 6.5535s FREE 30 μs
```

The program readout period is the period from address 0 of the program memory to address n, which is defined by the program length. The program length can be set between 8 and 131072 words in one word increments. When program execution reaches address n, the attenuation data at address n is held for the duration of Pause Time, after which readout of the program memory is repeated, starting again at address 0. The Pause Time is defined by number of readout clock cycles or as a time value.

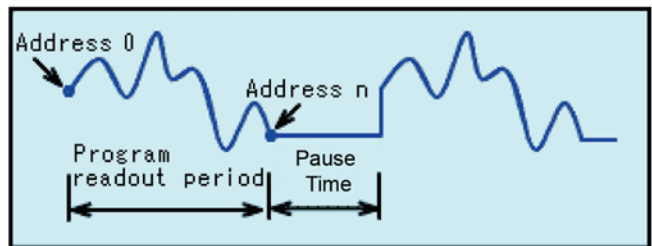

Program execution control modes

Readout of attenuation data is controlled by parameters Free, Burst and Gate. In FREE run mode, attenuation data (readout period) followed by a Pause Time period is clocked out continuously without the need of external trigger signals. In Burst mode, each rising edge of the trigger signal applied to TRIG IN triggers execution of the program memory. Pause Time does not apply. In Gate mode, one set of the readout period and Pause time intervals is repeated while the trigger signal is TTL high.

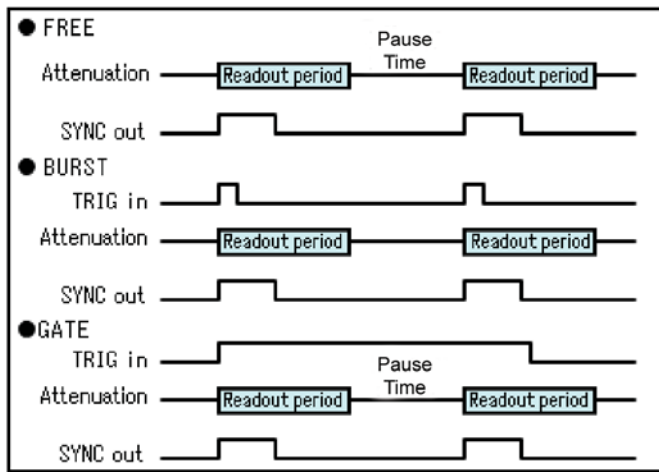

Filter setting

Use the built-in filter to reduce switching transients. To set the filter response time appropriately in relationship to the readout clock, a value of 1/2 to 1/8 of the clock period is recommended.

Application: Simulate signal path degradation of wireless communication link

Wireless communication equipment (e.g. CDMA, GSM, WLAN, Bluetooth) is subject to variations of received signal power due to obstacles and fading effects as the radio wave propagates through space. The 6010 series can be used to simulate these effects by generating a dynamic transmit power pattern with the included software tool. The test could be performed by placing the UUT (Unit Under Test) in one of B+K Precision's shielded RF enclosures.

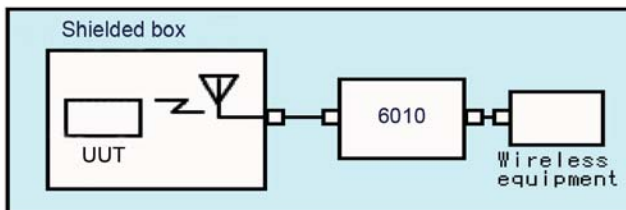

Intuitive software for generating attenuation programs

The 6010 series includes Windows® based software allowing users to quickly create and edit attenuation profiles and transfer the attenuation data points via RS232 interface to the instrument's internal memory. Parameters Readout Clock, Program Length, Pause Time, Readout Mode and Filter response time are set by the software but can also be modified from the front panel after attenuation data was downloaded.

Generate and edit attenuation profiles in many ways

- Enter standard waveforms: select one of the standard waveform types sine, triangle, square, ramp, sin x/x, exponential rise/fall and DC.
- Draw attenuation profiles freehand
- Enter attenuation data point by point and connect with straight line input
- Math operations: Edit a waveform by applying one of the following arithmetic operations to an existing waveform: addition, subtraction, clipping, absolute, mirror (reflection about time or attenuation axis), smoothing, resize and offset
- Edit waveforms using CUT, COPY, PASTE and UNDO.

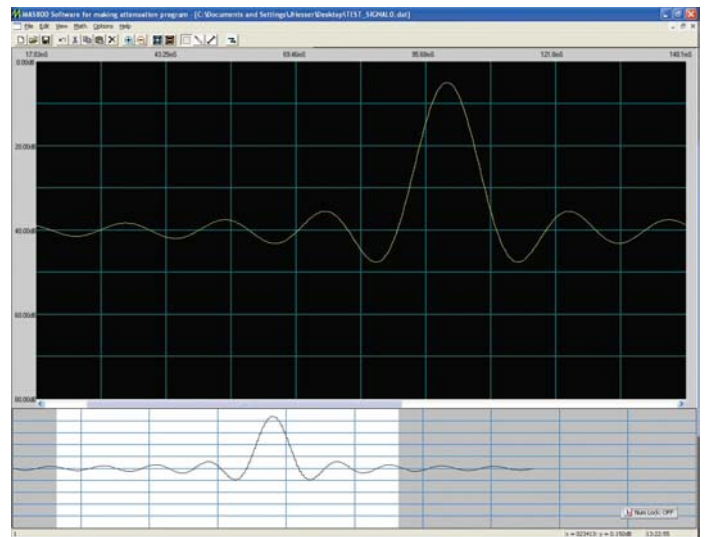

Specifications

models

	6010	6011	6012	6013
Frequency range	1.5 to 4.5GHz	3.0 to 9.0 GHz	4.5 to 13.5GHz	1.95 to 5.85GHz
VSWR	< 1.5 @ 2 to 4GHz < 2.0 @ 1.5 to 4.5GHz	< 1.7 @ 4 to 8GHz < 2.2 @ 3 to 9GHz	< 1.8 @ 6 to 12GHz < 2.2 @ 4.5 to 13.5GHz	< 1.6 @ 2.6 to 5.2GHz < 2.1 @ 1.95 to 5.85GHz
insertion loss (0dB setting)	< 2.3dB @ 2 to 4GHz < 2.6dB @ 1.5 to 4.5GHz	< 3.0dB @ 4 to 8GHz < 3.3dB @ 3 to 9GHz	< 3.5dB @ 6 to 12GHz < 3.8dB @ 4.5 to 13.5GHz	< 2.6dB @ 2.6 to 5.2GHz < 2.9dB @ 1.95 to 5.85GHz

Specifications

models

6010, 6011, 6012, 6013

Attenuator	
Setting range	0 to 80dB
Setting resolution	0.05dB
Accuracy (at center of frequency range and +10dBm input)	±0.5dB @ 0 to 10dB ±0.8dB @ >10 to 30dB ±1.0dB @ >30 to 50dB ±1.5dB @ >50 to 64dB ±2.0dB @ >64 to 74dB ±3.0dB @ >74 to 80dB
Impedance	50Ω nominal
Filter	1μs to 3ms, 1-3 step
Maximum input level	100mW @ CW or peak power
Input damage level	0.8W @ average power 20W @ peak power of 1μs pulse
Input / output connector	SMA
Readout clock input	
Input level	TTL
Maximum frequency	500kHz
Input impedance	10kΩ ±5%
Minimum pulse width	200ns (for TTL low and high)
Input damage level	±20V (DC + peak AC)
Connector	BNC
Trigger input	
Input level	TTL
Input impedance	10kΩ ±5%
Minimum pulse width	>1μs
Input damage level	±20V (DC + peak AC)
Connector	BNC
SYNC output	
Output level	TTL
Rise / Fall time	<100ns
Output impedance	approx. 100Ω
Connector	BNC
Functions	
Attenuation value set mode	Manual and Program
Program mode	
Program length	8 to 131072 words, (can be set in one word steps)
Readout clock	
Internal clock	100Hz to 500kHz, 1-2-5 step
External clock	DC to 500kHz
Manual clock	Press ENTER key for Single Trigger
Pause Time	
Clock setting	0 to 65535 readout clock cycles in 1 clock cycle increments

Time setting	0 to 6.5535sec (in 100μs increments)
Execution mode	Free, Burst, Gate
Nonvolatile program memory	Program data is automatically saved when power is turned off.
Software for generating attenuation programs	
Supported OS	Windows98/Me/2000/XP/Vista
Standard waveforms	Sine, Triangle, Square, Ramp, sin x/x, 1-e ^{-ax} , e ^{-ax} and DC
Parameters	Data length, Amplitude, Offset, Number of Cycles, Phase, Duty Cycle (only Square wave), Zero cross (only sinX / X), Damp Factor
Straight line	Connect two or multiple points with a straight line
Math functions	+, -, x, Clipping, Absolute, Mirror, Resize, Offset
Editing options	Cut, Copy, Paste, Undo, Delete
File menu	New, Open, Close, Save, Save as, Data import, Data export, Print, Printer setup, Transmit, Exit

Other

Display	LCD (backlit, 2 rows of 20 characters)
Interfaces	
RS-232C	Standard (baudrate: 2,400 to 57,600bps)
GPIB	Standard

Environmental

Operating temperature	0 to 40°C (Guaranteed at 23 ±5°C)
Operating humidity	less than 40°C / 80%RH (Guaranteed at less than 28°C / 80%RH)
Storage temperature	-10 to +60°C / less than 80%RH
Power Supply	90 to 132VAC / 180 to 250VAC (selectable by a switch located on rear panel)
Dimensions	8.11" (W) x 4.53" (H) x 14.18" (D) (excluding projections) 260 (W) x 115 (H) x 360 (D) mm (excluding projections)
Weight	10 lbs (4.5kg)

Accessories

One Year Warranty

SUPPLIED: Operating manual (1pc), Power cord (1pc), Fuse (1pc), Installation CD for creating attenuation profiles (1pc), RS-232C cable (1pc)



[Back to BK Precision 6010 Product Info Page](#)



[Visit us at www.TestEquipmentDepot.com](http://www.TestEquipmentDepot.com)