

Instruction Manual
for
Model 510A
Transistor
Tester

BK PRECISION

1031 Segovia Circle
Placentia, CA 92870-7137

TEST EQUIPMENT DEPOT
99 WASHINGTON STREET
MELROSE, MA 02176-6024
TEL: 800 517 8431
FAX: 781 665 0780

WWW.TESTEQUIPMENTDEPOT.COM

TABLE OF CONTENTS

	PAGE
INTRODUCTION AND SPECIAL FEATURES	3
SPECIFICATIONS	4
BRIEF SUMMARY OF WHAT THE 510 WILL DO	5
CONTROLS AND INDICATORS	6
HINTS AND KINKS	8
THINGS TO KNOW ABOUT THE 510	9
USING THE MODEL 510	
In-Circuit Testing	10
Out-Of-Circuit Testing	12
HOW THE 510 WORKS	
Test Switch	15
Test Circuitry	15
OPERATIONAL TESTS AND BATTERY CHECK	18
SERVICE	19
WARRANTY SERVICE INSTRUCTIONS	19
WARRANTY	20

INTRODUCTION

The Model 510 Transistor Testor is designed for in-circuit and out-of-circuit transistor testing.

It uses both a high current, low duty-cycle pulse technique to test transistors in the presence of shunting circuitry, and a low current drive system which enables the user to identify the terminals of the device in most in-circuit tests and all out-of-circuit checks.

The instrument is designed for a minimum amount of control manipulation, making for rapid testing of most devices.

SPECIAL FEATURES

1. Patented limited-energy pulse circuit permits highly successful use of in-circuit testing in the presence of low shunt impedances with complete safety for the device under test.
2. LO drive provides positive detection of high-leakage and low-gain devices.
3. A human-engineered panel design which eliminates the need for reference to the operating manual – only two switches, no panel adjustments.
4. Six position TEST switch sequentially connects the device being tested in all possible configurations, making it unnecessary to know the device terminal identification.
5. Base or gate lead identified by color as TEST switch is operated when testing with HI drive.
6. All leads of a transistor are identified when testing with LO drive.
7. Automatic polarity indication to identify NPN or PNP type devices.
8. Clip-on test leads that make positive connections to devices in difficult locations. Free operator's hands to make further tests.
9. Choice of test leads or top panel socket for out-of-circuit tests.
10. Battery operated in small portable package. Works anywhere.
11. Complete with carrying case which provides for test lead storage.
12. Flashing light reminds operator to turn instrument off when not in use.

SPECIFICATIONS

IN/OUT-OF-CIRCUIT

GOOD/BAD Test for transistors, FET's or SCR's.
Identifies transistor as NPN or PNP and FET as N or P channel.
Identifies gate lead of FET.
Identifies base lead of transistor when using HI drive.
Identifies all leads of transistor when using LO drive.
Identifies all leads of SCR.

APPLIED TEST CURRENTS

Base Drive: 250 mA (HI drive) or 1 mA (LO drive) at 2% duty cycle.
Collector Drive: 125 mA at 2% duty cycle.
Test Repetition Rate: 5 per second.

LIMITING IN-CIRCUIT SHUNT VALUES FOR VALID GOOD/BAD TEST

Resistance: Down to 10 ohms with HI drive.
Down to 1.5k ohms with LO drive.
Capacitance: Up to 25 mfd with HI drive.
Up to .3 mfd with LO drive.

POWER REQUIREMENTS

6 VDC, standby current, 4 mA. Average testing current, 12 mA.
Uses 4 "AA" cells.

ACCESSORIES

Carrying case with test lead storage included.
Three test leads with mini-lock clips supplied.

SIZE

7.5 x 4.0 x 2.0".

WEIGHT

1 lb., with batteries.

BRIEF SUMMARY OF WHAT THE 510A WILL DO

1. Determines good or bad transistors, FET's and SCR's in or out-of-circuit.
2. Identifies Emitter-Base-Collector leads of transistors.
3. Identifies gate lead of FET's.
4. Identifies Cathode-Gate-Anode leads of SCR's.
5. Indicates polarity of good devices (NPN or PNP; N or P channel).
6. Determines whether device is transistor, FET or SCR.
7. High-leakage and low-gain devices are positively detected when tested with LO drive.

CONTROLS AND INDICATORS

1. **OFF/LO/HI SWITCH:** Applies power to the 510 when switched to the LO or HI positions.
In the LO position, the 510 will identify all leads of a good transistor out-of-circuit, and in-circuit, if not heavily shunted (see "SPECIFICATIONS").
In the HI position the 510 will test transistors in-circuit; FET's and SCR's both in and out-of-circuit.
2. **TEST LAMP:** Flashes when 510 is ready to test. Turns off when either the NPN or PNP lamp indicates a good device.
3. **TEST SWITCH:** Selects proper device connection for testing and lead identification.
4. **LEAD IDENTIFICATION INDICATOR:** Identifies leads by color.
5. **NPN and PNP LAMPS:** Indicate polarity of good devices.

CONTROLS AND INDICATORS

1. **OFF/LO/HI SWITCH:** Applies power to the 510 when switched to the LO or HI positions.
In the LO position, the 510 will identify all leads of a good transistor out-of-circuit, and in-circuit, if not heavily shunted (see "SPECIFICATIONS").
In the HI position the 510 will test transistors in-circuit; FET's and SCR's both in and out-of-circuit.
2. **TEST LAMP:** Flashes when 510 is ready to test. Turns off when either the NPN or PNP lamp indicates a good device.
3. **TEST SWITCH:** Selects proper device connection for testing and lead identification.
4. **LEAD IDENTIFICATION INDICATOR:** Identifies leads by color.
5. **NPN and PNP LAMPS:** Indicate polarity of good devices.

TEST EQUIPMENT DEPOT
99 WASHINGTON STREET
MELROSE, MA 02176-6024
TEL: 800 517 8431
FAX: 781 665 0780

WWW.TESTEQUIPMENTDEPOT.COM

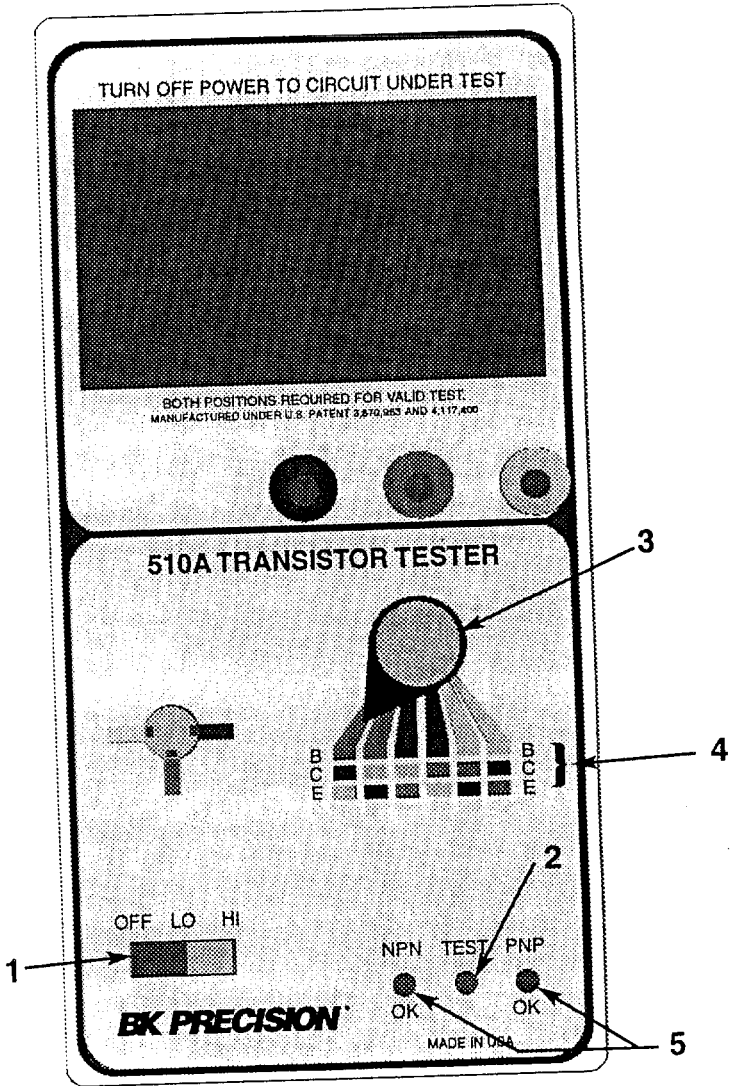

Fig. 1. Front panel showing controls and indicators.

HINTS AND KINKS

IDENTIFYING TRANSISTORS AND DIODES

1. Nearly all germanium transistors come in metal cases, either the tubular type with flexible leads, or in the standard TO-5 package.
2. Power transistors in stud packages or in the TO-5 or TO-3 can be either germanium or silicon, depending on age. Two and three digit 2N-numbers are mostly germanium.
3. The TO-66 power transistors and the plastic power tab packages are nearly always silicon. The collector is usually, but not always, connected to the mounting tab and the center lead.
4. The base lead of most modern plastic type transistors is either the center lead or the right hand lead when facing the flat side with the leads down. In the latter case the collector lead is in the middle.
5. Most plastic FET's have the gate lead on the right side when facing the flat side with the leads down and the source in the middle, but there are exceptions. With nearly all junction FET's, the source and drain can be interchanged with no adverse effects.
6. All transistors will have some gain with the collector and emitter leads interchanged, with the exception of Darlingtons.
7. Germanium signal diodes usually can be recognized by their transparent hollow glass cases with either three or four color bands, or type numbers printed on them. Silicon diodes are usually painted, because silicon is light-sensitive and must be protected from ambient light. The "moose" types, such as the stud package, can be either germanium or silicon.

THINGS TO KNOW ABOUT THE 510A

1. There are certain semiconductor devices that look like transistors which the 510 *cannot* test. These include: Triacs, diacs and diode arrays.
2. In HI drive, most transistors that test GOOD will do so in *two* adjacent TEST switch positions. This is because transistors have some gain when the collector and emitter are interchanged. If the circuit is heavily shunted, or the "reverse beta" of the transistor is very low, the transistor will test good in only *one* TEST switch position. In either case, the transistor can be considered GOOD.
3. In LO drive, most transistors that test GOOD will do so in only *one* TEST switch position. In some rare cases, high-frequency transistors or transistors with higher than usual "reverse beta" may test GOOD in *two* adjacent TEST switch positions having the same base color shown by the Lead Identification Indicator. This is still a valid GOOD test, but only the base lead of the transistor can be identified.
4. FET's can be tested in either LO or HI drive, but only FET's with a high G_m will test good in LO drive. Therefore, to insure a valid GOOD/BAD test for all junction FET's, the DRIVE switch should be set to HI when the device being tested is known to be a FET. The 510 detection circuitry is more sensitive in the HI drive position.
5. TV horizontal output transistors have a very low gain (typically 5) and will not test good in any TEST switch position.

USING THE 510A

IN-CIRCUIT TESTING

CAUTION

Make sure all power is turned off in the circuit being tested, and that all capacitors are discharged.

A. Transistors/FET's

1. Set the OFF/LO/HI switch to the LO position.
2. Connect the three test leads in any manner to the three leads of the device you wish to test.
3. Move the TEST switch slowly through its six positions or until one of the two red lamps glow indicating whether the device is NPN or PNP, or N or P channel (the NPN lamp will glow if the FET is N channel and the PNP lamp will glow if the FET is P channel). In LO drive, most transistors that test good will do so in only *one* TEST switch position (see THINGS TO KNOW ABOUT THE 510). In this TEST switch position, all the leads of the transistor can be identified as shown by the colors on the Lead Identification Indicator. Most FET's will test good (LO or HI drive) in *two* adjacent TEST switch positions having the same base color shown by the Lead Identification Indicator, since practically all junction FET's are symmetrical. The base color indicated is the *gate* lead of the FET.
4. If neither the NPN nor PNP lamp glows as the TEST switch is slowly moved through its six positions, in LO drive, then the device under test is one of the following:
 - a. Transistor with high leakage or very low gain (may not function properly in circuit).
 - b. Device with open/shorted elements.
 - c. Device with excessive circuit shunting (see "SPECIFICATIONS").
 - d. FET that will not test with LO drive.
 - e. Horizontal output transistor with very low gain (typically 5).
5. Retest the device using HI drive. In HI drive, most transistors that test good will do so in *two* adjacent TEST switch positions having the same base color shown by the Lead Identification Indicator. Only the base lead of the transistor can be identified.
6. If the device tests good using HI drive, then 4(a) above could be true.

7. If the device does not test good in any TEST switch position, in HI drive, remove the device from the circuit and retest using OUT-OF-CIRCUIT procedures.

B. SCR's

1. Set the OFF/LO/HI switch to the HI position.
2. Connect the three test leads in any manner to the three leads of the SCR you wish to test.
3. Move the TEST switch slowly through its six positions. Most SCR's will indicate NPN in one TEST position and PNP is another position that does not have the same base color. Some medium and high voltage SCR's may give only an NPN indication.
4. The SCR is good if an NPN indication is obtained. The additional PNP indication, if obtained, merely confirms that the device is an SCR rather than a transistor.
5. With the TEST switch in the position that gives an NPN indication, lead identification is thus: base color is gate lead, emitter color is cathode lead, and collector color is anode lead.
6. If the SCR does not test good in any TEST switch position, then it should be removed from the circuit and tested again (may be subject to excessive shunting in circuit).

C. "Hands Off" Testing

When the base lead of devices being tested can be identified, leave the TEST switch in the extreme left position. The transistors can then be probed one by one by connecting the green lead to the base, and the blue and yellow leads to the collector and emitter respectively. The NPN and PNP lamps will tell you when the transistor is good. Occasionally, the collector and emitter leads may have to be interchanged to produce a good indication.

The "Hands Off" method is useful when it is necessary to test a number of transistors in a circuit, or when it is impossible to connect all three leads to the device being tested: If one lead can be clipped on the device, both hands are free to probe the remaining two leads. With this feature, you can also use the DYNAFLEX MODEL FP-5 PROBE (optional) to test devices from either side of the P.C. board.

D. Intermittent Testing

Often the Model 510 can be used to identify intermittent transistors in a circuit. Connect the test leads to the suspected transistors and move the TEST switch until one of the indicator lamps glow. Then, leaving the 510 in this switch position, the transistor can be subjected to various physical tests such as tapping, heating, or cooling. An intermittent transistor will show up as an intermittent flicker of the indicator lamp.

HINT

A can of "Instant Cold Spray" is quite useful for providing rapid cooling of discrete components.

OUT-OF-CIRCUIT TESTING

A. Transistors

1. Set the OFF/LO/HI switch to the LO position.
2. Connect the three leads to the device or plug it into the convenient test socket on the Model 510 panel (no need to worry about Lead Identification).
3. Slowly move the TEST switch until the 510 indicates a good transistor. Leave the TEST switch in this position and identify all the leads of the transistor by the colors shown on the Lead Identification Indicator. In LO drive, the transistor should test good in only *one* TEST switch position, (see THINGS TO KNOW ABOUT THE 510).
4. If neither the NPN nor PNP lamp glows as the TEST switch is slowly moved through its six positions, in LO drive, then the device under test is one of the following:
 - a. Transistor with high leakage or very low gain (may not function properly in circuit).
 - b. Transistor with open/shorted elements.
 - c. Device is a FET. If this can be verified from available service information, retest as outlined below.
 - d. Device is a power darlington which requires high base drive voltage. If this can be verified from service information available, retest using HI drive.
 - e. Horizontal output transistor with very low gain (typically 5).
5. Retest the device using HI drive. In HI drive, most transistors that test good will do so in *two* adjacent TEST switch positions having the same base color shown by the Lead Identification Indicator. Only the base lead of the transistor can be identified.

6. If the device tests good using HI drive, then 4(a) above could be true.

B. FET's

1. Set the OFF/LO/HI switch to the HI position.
2. Slowly move the TEST switch until the 510 indicates a good FET.
3. J-FET's will indicate good in *two* adjacent TEST switch positions which have the same base color. (Most J-FET's are symmetrical.)
4. The base color shown by the Lead Identification Indicator is the *gate*.
5. If neither the NPN nor PNP lamp glows, then the FET under test is defective.

C. SCR's

1. Set the OFF/LO/HI switch to the HI position.
2. Connect the three leads to the SCR or plug the SCR into the test socket on the front panel of the tester (no need to worry about lead identification).
3. The test procedure is the same as for in-circuit testing of SCR's (page 11).

A GOOD indication verifies that the SCR can be triggered into conduction, and in most cases this is sufficient testing. However, it is sometimes desirable to additionally test whether or not the SCR's forward blocking voltage is normal. Transistor testers of this type do not test forward blocking voltage, but such a test can be performed with a High Voltage Power Supply. The power supply must have a current limiting feature to protect the SCR under test. It must also provide adequate voltage to test the SCR. The procedures for conducting a forward blocking voltage test are as follows:

1. Set the power supply current limiter to approximately 25mA.
2. Connect the SCR to the power supply as shown in Fig. 2.
3. Monitor power supply voltage and current.
4. Slowly increase the power supply voltage to the forward blocking voltage rating of the SCR under test.
5. Power supply current should remain low throughout step 4; up to a few mA leakage current is normal for some high circuit SCR's. If the SCR fires as the voltage is being increased in step 4, the SCR is defective. Firing is denoted by a sudden current jump to the current limiting value.

WARNING: EXPOSED HIGH VOLTAGE. TAKE PRECAUTION TO PREVENT ELECTRIC SHOCK.

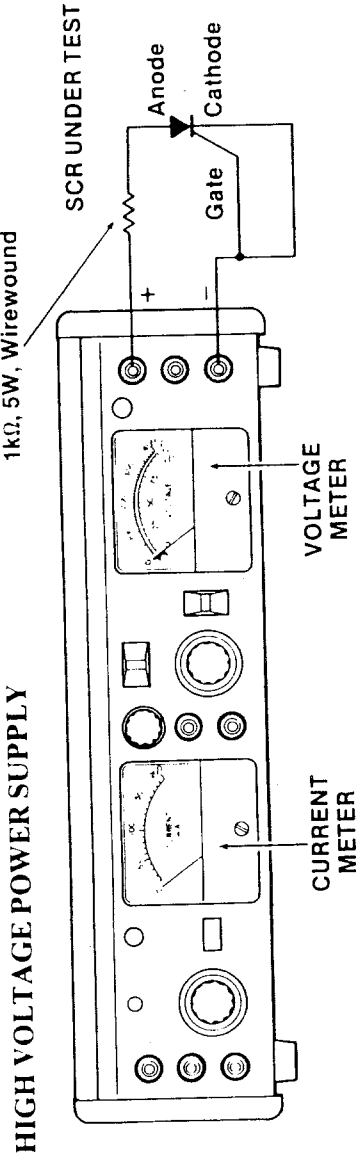

1. Set current limit to 25 mA.
2. Increase voltage to rating for SCR under test.
3. If OVERLOAD trips, SCR is defective.

Fig. 2. Forward blocking voltage test of an SCR.

HOW THE 510A WORKS

TEST SWITCH

1. The 510 Transistor Tester uses a six-position rotary switch located on the top panel to connect the device being tested in the correct manner for testing. As this switch is rotated, the device connected to the three test leads or plugged into the socket is connected in all possible configurations to the testing circuit. The extreme left position is the "normal" connection, in that the blue, green, and yellow leads are connected to the collector, base and emitter circuits respectively.
2. In two of the six positions, using HI drive, the device is connected properly for testing. This is true since almost all transistors have gain, although usually very little, when the collector and emitter are interchanged, and most junction FET's are symmetrical. The two positions are always adjacent, and always display the same base color by the Lead Identification Indicator whenever the 510 is indicating a good device.

In LO drive, a transistor should indicate good in only one switch position since limited base drive allows the detector to test the transistor as a good device in only the high gain connection.

TEST CIRCUITRY

3. The 510 circuitry uses two clock generators that produce a series of pulses designed to periodically test a transistor about five times per second. These short, high current pulses apply a voltage pulse to the collector, first positive for testing NPN devices, followed by negative for testing PNP (see Fig. 3A). During this pulse, a shorter pulse of the same polarity is applied to the base of the device, which drives the collector voltage toward saturation.

Taking a closer look at the basic timing circuitry, refer to Fig. 3. T1 is the period clock, which runs at approximately 5 Hz. It initiates each test period while simultaneously resetting FF1 and FF2. T2 runs at 500 Hz and controls the pulse-forming circuits.

4. The pulse-forming circuit uses a combination of toggles and RS flip-flops to produce the proper sequence of pulses for the collector drive circuit A and the base drive circuit B. A and B are level-shifting complementary drivers which can deliver several hundred milliamperes at +3V and -3V or return to zero volts.
5. A properly connected NPN transistor, as shown above, will see the waveform at Fig. 3A, and its base will see the waveform at Fig. 3B. Note that during the positive excursion of the collector voltage, the base is driven first negative and then positive. If the transistor being tested is NPN, the collector voltage will drop abruptly when its base is

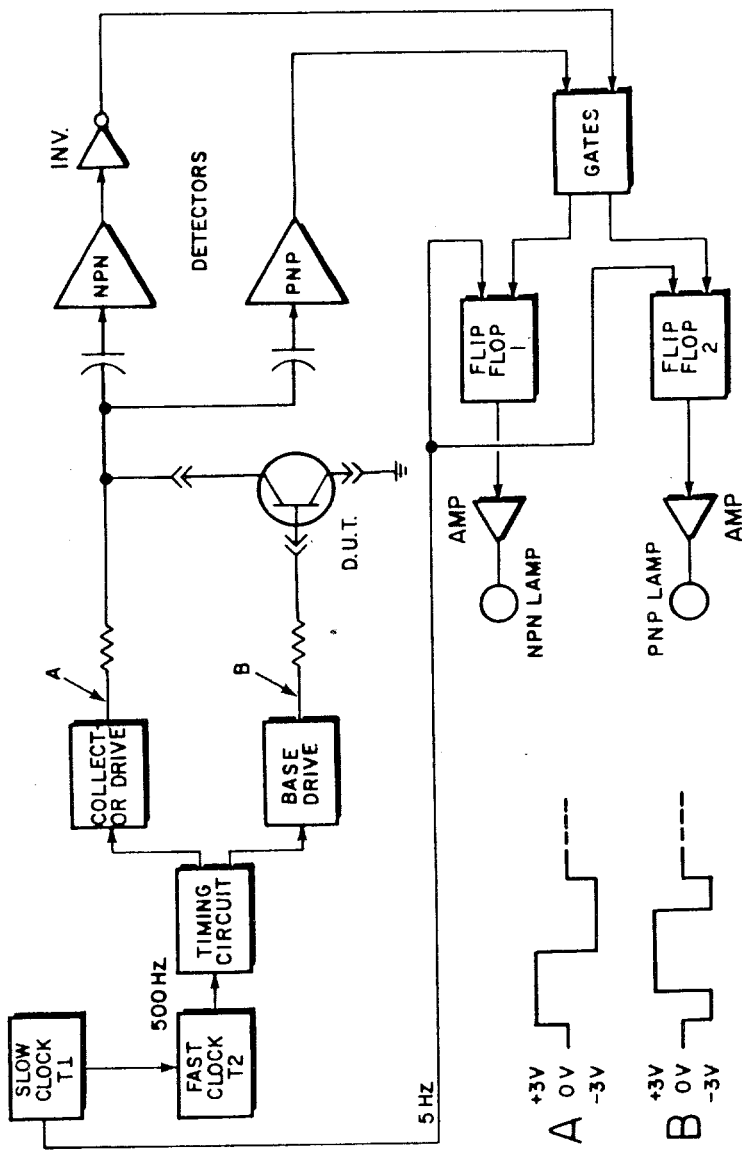

Fig. 3. Block diagram.

driven positive. This negative-going transition, which will only occur if transistor action is present, is differentiated and the differentiated signal is used to latch flip-flop 1.

If a PNP transistor is tested, the turn-on transition occurs in the second half of waveform 3A, and in the opposite direction.

The PNP output pulse is not inverted through the detector in order to provide the proper polarity to operate flip-flop 2. Of course, other pulses appear at the differentiator output, since all voltage transitions are similarly differentiated, but the synchronized gating circuits prevent the unwanted pulses from reaching the lamp driving flip-flops and thus eliminating wrong indications.

The input to FF1 is only enabled during the time period in which an NPN device can be detected and similarly, FF2 is only enabled when a PNP device can be detected. Only the flip-flop which corresponds to the type of device being tested can be latched, lighting the lamp corresponding to that device.

The output of FF1 or FF2 is either +3V or -3V, depending on whether the device tested was PNP or NPN. This output in turn drives an amplifier which produces enough current to turn on the indicator lamp.

OPERATIONAL TESTS AND BATTERY CHECK

1. To test for proper output drive power, the circuit in Fig. 4 can be easily used to insure that the 510 is operating according to specifications. The 510 must be switched to the HI drive position. Transistor should check good in only one switch position.

The circuit in Fig. 4 will also serve as a good battery check for the 510, because optimum drive is required for the transistor in the circuit to test good.

2. To test the LO drive function of the 510, eliminate R1 and replace R2 with a 1.5k Ω resistor in Fig. 4. The transistor should check good in only *one* TEST switch position.

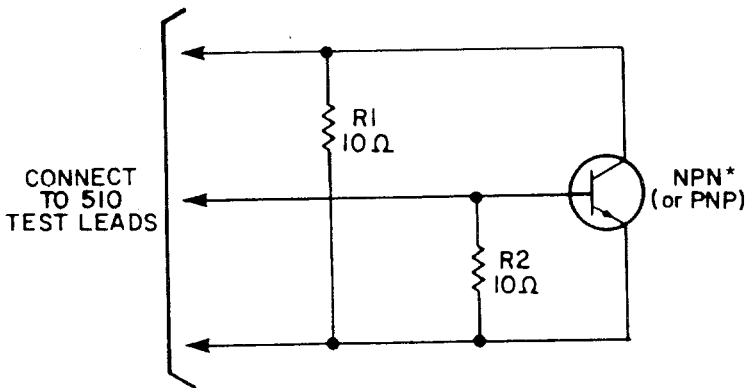

* GENERAL PURPOSE TRANSISTOR WITH
A BETA OF 100 OR GREATER.

Fig. 4. Output drive and battery check.