

Part No. 991751
10/90

**OPERATING
INSTRUCTIONS
FOR
AMPROBE®
TRUE RMS AC
VOLTAGE/CURRENT
RECORDER**

**MODELS
LAV21RMS and LAV21RMS-T**

**See Precautions for Personal and Instrument
Protection on Page 3**

See Limited Warranty on Page 2



**Test Equipment
Depot**

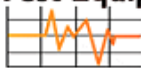

1-800-517-8431

99 Washington Street
Melrose, MA 02176
Fax 781-665-0780
TestEquipmentDepot.com

PRECAUTIONS FOR PERSONAL AND INSTRUMENT SAFETY

1. Read these instructions thoroughly and follow them carefully.
2. In many instances you will be working with dangerous levels of voltage and/or current, therefore, it is important that you avoid direct contact with any uninsulated, current-carrying surfaces. Appropriate insulating gloves and clothing should be worn.
3. Before connecting or disconnecting the voltmeter to or from the circuit to be tested, turn off all power to the circuit.
4. Before applying test leads to circuit under test, make certain:
 - a. Proper test leads are plugged into correct instrument jacks, and
 - b. Selector switch is set to proper range.
5. Before using any electrical instrument or tester for actual testing, the unit should be checked on a known live line to make certain it is operating properly.
6. If the instrument should fail to indicate, do not touch circuit until you have checked to see that all instrument switches are in proper position and instrument has been checked on a known live circuit.

IMPORTANT: Failure to follow the instructions or to observe the above precautions may result in personal injury and/or damage to the instrument and/or accessories.

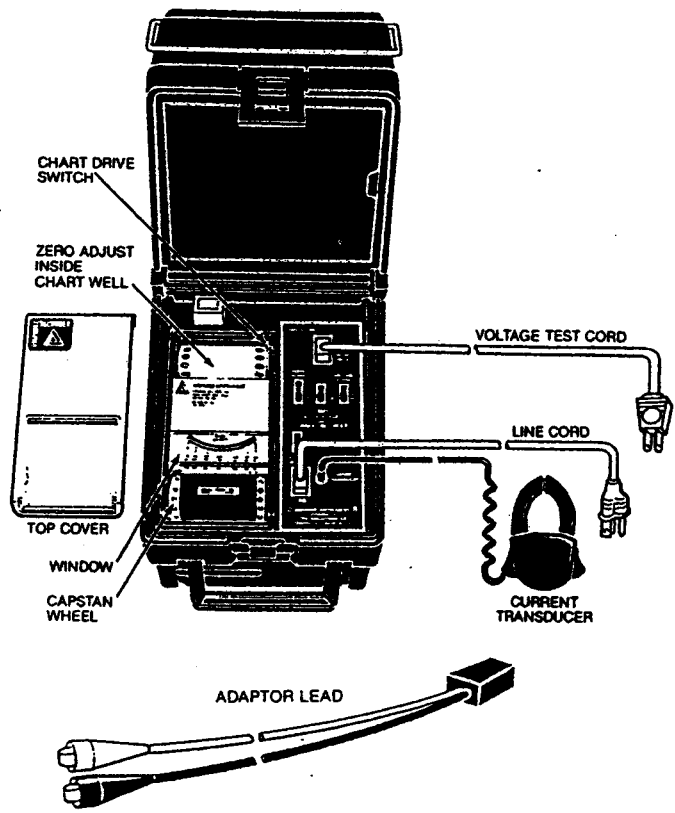

MODEL LAV21RMS

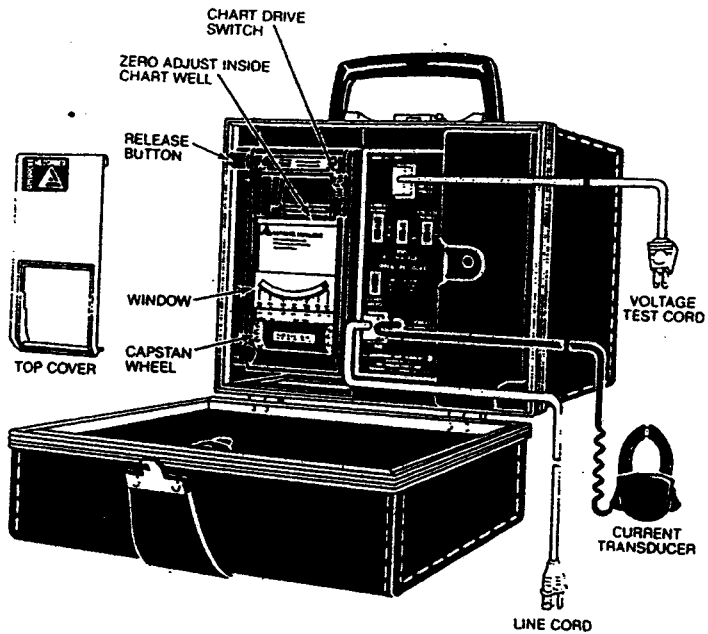

MODEL LAV21RMS-T

SPECIFICATIONS

AC Voltage/Current (True RMS, AC-Coupled)

Ranges: 0-150/300/600 Volts 1 ϕ
0-15/60/150/300 Amps 1 ϕ

Accuracy: $\pm 3\%$ of full scale from 50-70Hz.
 $\pm 5\%$ of full scale from 70-400Hz.

Crest Factor: 3:1 max.

Power Requirements: 120 Volts 60Hz, 3 Watts
(unless otherwise indicated)

Chart Speed: 1" (2.54 cm)/hr., 6" (15.24 cm)/hr.,
12" (30.48 cm)/hr.

Imprint Rate (LAV21RMS): 1 per min. @ 1"/hr., 1 per 10 sec.
@ 6"/hr., 1 per 5 sec. @ 12"/hr.

Imprint Rate (LAV21RMS-T): 1 per 30 sec. @ 1"/hr.,
1 per 5 sec. @ 6"/hr.,
1 per 2.5 sec. @ 12"/hr.

Operating Temperature: 32°F (0°C) to 122°F (50°C)

Chart: Cat. No. 300SVA for LAV21RMS or
Cat. No. 300SVA-6 for LAV21RMS-T

ZERO ADJUSTING

With chart drive switch in "OFF" position (see fig. 1) exposing the word "OFF," check mechanical zero setting of pointer (see fig. 2) before making any electrical connections to the instrument. If adjustments are necessary proceed as follows:

- Remove top cover—pull bottom ledge of frame toward you and lift. See fig. 3 or 4.
- With strip chart roll not in recorder, locate star wheel. See fig. 5 or 6.
- Apply finger to star wheel and turn until pointer lines up with zero mark at the extreme right of scale. See fig. 2.

Fig. 1
OFF Position

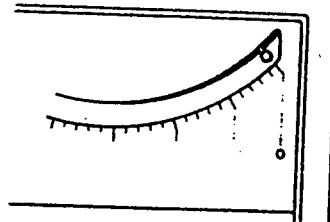
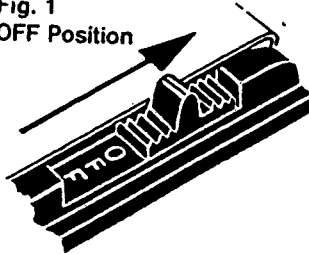

Fig. 2

Fig. 3
Pull
Lift
Up

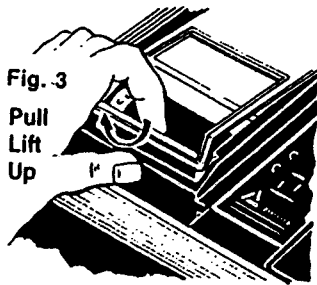

Fig. 4
Pull
Lift
Up

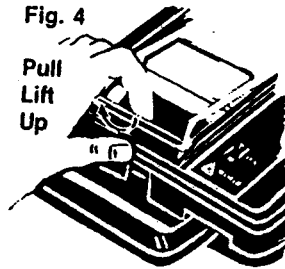

Fig. 5

**Zero Adjust
Star Wheel**



Fig. 6

**Zero Adjust
Star Wheel**

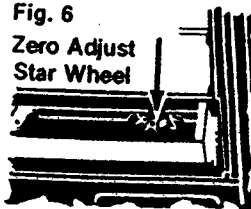

LOADING AND UNLOADING CHART PAPER MODEL LAV21RMS

1. Move chart drive switch to OFF position exposing the word "OFF." See fig. 1.
2. Remove top cover. See fig. 4.
3. Unroll about nine (9) inches of chart paper.
4. With printed side up, slip leading edge of paper under the glass and out, through slot in front as shown in fig. 7.
5. Make sure the holes on both sides of the chart paper engage the sprockets of both capstan wheels.
6. Line up time arrow (see fig. 8) with any line on the left of the chart paper.
7. To unload chart paper, turn chart drive switch off and remove paper.

Fig. 7

**Slot to Feed
Paper Out
Front**

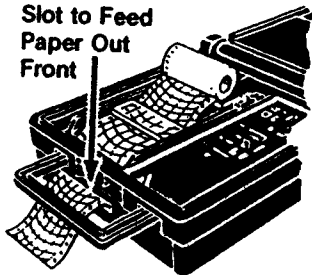
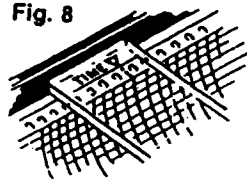

Fig. 8



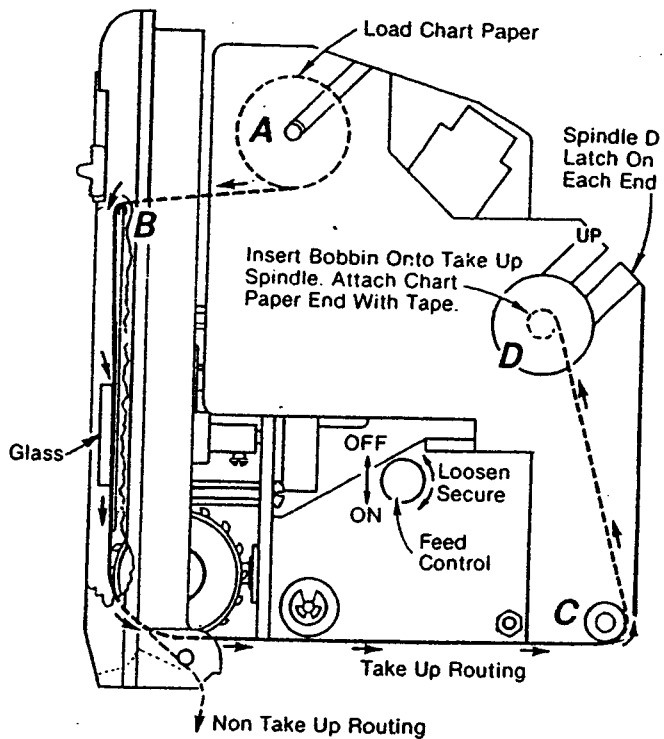

Fig. 9

LOADING AND UNLOADING CHART PAPER MODEL LAV21RMS-T

1. Move chart drive switch to OFF position exposing the word "OFF." See fig. 1.
2. Remove top cover. See fig. 3.
3. To insert or remove chart paper, place recorder in horizontal position and press the release button in the direction shown in fig. 10. Raise the recorder mechanism to a vertical position until it locks. Remove feed shaft **A** (see fig. 9) and place chart roll on spindle. Remove tape on roll and retain tape for securing chart on take-up spindle **D**. Unroll about 12" to 15" and route paper over top edge of scale plate **B** underneath glass, over the sprocket wheels, to the rear and over the idle roller **C** up to the cardboard bobbin mounted on take-up spindle **D**. Secure edge of chart to bobbin with tape. Make sure the sprocket holes in the paper engage the sprocket wheels. Be sure that feed control is tight and in the right position. The word "on" must be visible. Press in the idle roller extension **C** to allow the recording mechanism to move back down into case and lock into position. Replace cover by positioning the "U" bend onto the plastic projections and snap front down. Make sure chart paper is not binding with the cover in place. For "non-take-up" recording, route chart through bottom slot as shown in fig. 9.
4. To remove chart from take-up spindle **D**, move the latches away from the take-up spindle. Turn knurled knob on spindle **D** until the slot in the take-up drive pulley at the opposite end of the spindle is lined up with the slot in the side frame of the recorder. Slide the spindle and chart up and out of the slots in the side frames of the recorder. Remove tape from chart and bobbin.
5. To unload chart paper from recorder turn chart drive switch off, exposing the word "OFF." See fig. 1. Follow 4 above. Remove chart from feed shaft **A** and pull paper through recorder.



Fig. 10

HOW TO USE AS A RECORDER

1. Zero adjust recorder. See "ZERO ADJUSTING."
2. **FOR VOLTAGE AND AMPERE RECORDING:**
Set range selector switch to appropriate range. Push "VOLTS-VIA-AMPS" switch to the "VIA" position. Plug voltage test lead into volts receptacle and connect to voltage source to be measured with adaptor leads, if necessary. Plug current transducer into jack on panel and snap transducer around one leg of the line going to the load.
3. **FOR VOLTAGE RECORDING ONLY:**
Set volt range selector switch to appropriate range (see fig. 8). Move "VOLTS-VIA-AMPS" switch to the "VOLTS" position. Plug test leads into volts receptacle and connect to voltage source to be measured with adaptor leads, if necessary.
4. **FOR AMPERE RECORDING ONLY:**
Set ampere range selector switch to appropriate range. Push "VOLTS-VIA-AMPS" switch to the "AMPS" position. Plug current transducer into jack on panel and snap transducer around one leg of the line going to the load.
5. Plug power line cord into recorder line receptacle and connect to proper line voltage and frequency.
6. Push chart drive switch to "ON" position exposing the word "ON." Make sure switch clicks into detent position which locks it into place. See fig. 11.
7. Mark time of start on chart paper. See fig. 8.
8. Secure recorder in a horizontal or vertical position.

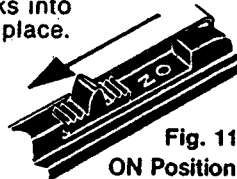

Fig. 11
ON Position

HOW TO USE AS AN INDICATING METER

1. Set chart drive switch to "OFF" position. See fig. 1.
2. Remove chart paper and zero-adjust pointer. See "ZERO ADJUSTING" for more details.
3. Follow steps 3, 4 and 5 above.

Caution: Recorder must be powered before taking any readings.