

# AT-3000 PRO User Guide



This User Guide covers the use of the underground wire tracer, the AT-3000 PRO.

The AT-3000 PRO consists of receiver the R-3000 PRO and Generator, the G-3000 PRO.

The R-3000 PRO provides four detection modes, audio and visual indication and depth measurement.

**Test Equipment Depot**  
1-800-517-8431

99 Washington Street  
Melrose, MA 02176  
Fax 781-665-0780  
TestEquipmentDepot.com



## R-3000 PRO Locator features

### 1 On/Off

Press and hold to use R-3000 PRO

### 2 Loudspeaker

Detachable speaker for use in noisy environments

### 3 LCD Display

### 4 Sensitivity Control

### 5 Function Switch

Selects locate mode

### 6 Battery compartment

To replace batteries, open the access cover using a screwdriver or coin. Use two LR20 or D type alkaline batteries (or equivalent NiMH rechargeable batteries)

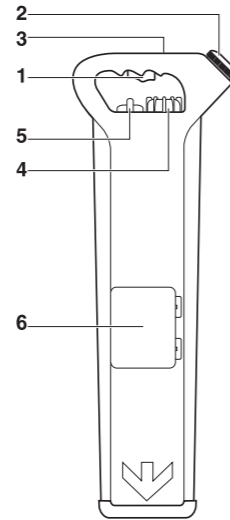

### WARNING

**When using the R-3000 PRO in noisy environments, the speaker can be detached and held closer to the ear. To avoid excessive noise exposure it is advisable to hold the speaker no closer than 15cm (6") from the ear. Prolonged use at this level should be avoided.**

## G-3000 PRO Signal Generator features

### 1 On/Off button

Press to switch On and Off. Press and hold to reduce volume

### 2 Direct connection socket

### 3 Loudspeaker

### 4 Battery compartment

To replace batteries, open the access cover using a screwdriver or coin. Use four LR20 or D type alkaline batteries (or equivalent NiMH rechargeable batteries)

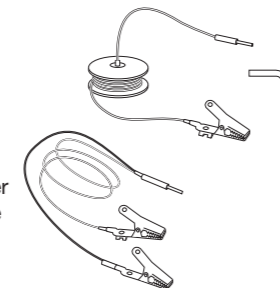
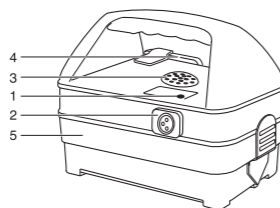

### 5 Storage compartment

Holding connection cable, Ground stake and ground cable

### 6 Pulse/Continuous switch

## R-3000 PRO LCD features

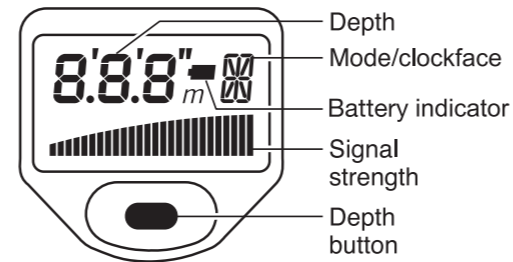

The R-3000 LCD display provides visual representation of the following parameters:

- Depth
- Battery indicator (flashing icon indicates that batteries are low)
- Signal strength indicator
- Mode/clockface indicator
- Depth button

## Operation of Power, Radio and AvoidanceScan™ modes

**Regularly check your AT-3000 PRO, in all modes, over a cable which gives a response you are familiar with.**

### AvoidanceScan™

Use the AvoidanceScan™ mode to undertake an initial sweep of an area to be excavated. AvoidanceScan™ will detect all modes simultaneously.

**Power signals:-** radiated by loaded, unbalanced cables. These signals are also found on other nearby conductors that 're-radiate' the power signal.

**Radio signals:-** originate from distant radio transmitters. These penetrate the ground and are re-radiated by buried conductors. However, they are not always present.

**G-3000 PRO signals:-** present on buried conductors that have had a G-3000 PRO signal applied. There are various ways of applying the G-3000 PRO signal (see Locating with the AT-3000 PRO).

### Using AvoidanceScan™

Grip the handle.

Squeeze trigger and listen for bleep indicating the batteries are OK. Replace both batteries if there is no bleep or if the battery icon is flashing.

Turn Function Switch to A (AvoidanceScan™) to sweep the area for conductors radiating Power, Radio or Genny signals. **In this mode the depth button will not be active and the sensitivity control will only adjust the G-3000 PRO signal level. (P and R will be set to maximum sensitivity).**

Keep the sensitivity at maximum unless there is a blanket G-3000 PRO signal, in which case turn down the sensitivity until the blanket G-3000 PRO signal is reduced to a usable level.

### Note

Best results are obtained in the AvoidanceScan™ mode when the G-3000 PRO is set to pulse operation.

Sweep the area to be excavated with a steady and deliberate motion. Hold the R-3000 PRO with the blade vertical and with the bottom end just above the ground. Ensure the whole area is covered by adopting a grid pattern.

Maximum meter and speaker response indicates the position of a buried conductor.

If necessary switch to a dedicated mode (PR or G-3000 PRO) to pinpoint the conductor, adjusting the signal level control to give a narrow locate band over the conductor. Rotate the R-3000 PRO to give maximum response. The R-3000 PRO is now at right angles to the conductor. (This can be less precise in the power mode because of the nature of the power signal).

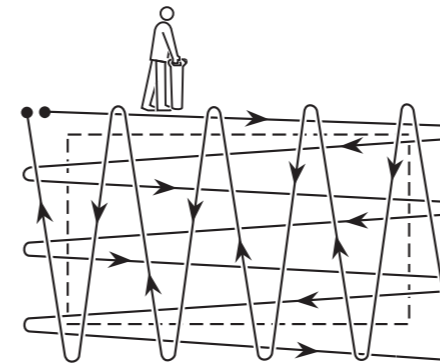

Trace the buried conductor keeping the R-3000 PRO vertical and moving it steadily from side to side. Follow the line of the buried conductor marking it with chalk or paint across the area to be excavated.

Switch back to AvoidanceScan™ mode to resume the sweep of the area to be excavated.

## Operation of Power and Radio modes

Power and Radio modes can be used independently of AvoidanceScan™ and it is recommended that this is done to pinpoint services in very congested areas.

**Regularly check your AT-3000 PRO, in all modes, over a cable which gives a response you are familiar with.**

### Using Power mode

Select Power using the function switch.

Grip the handle.

Squeeze trigger and listen for bleep indicating the batteries are OK. Replace both batteries if there is no bleep or if the battery icon is flashing.

Rotate the Sensitivity Control fully clockwise for maximum sensitivity but reduce if there is a blanket signal across the site.

Define the area to be excavated and carry out a grid pattern sweep as described in AvoidanceScan™.

The presence of a buried metallic pipe or cable will be indicated by a tone emitted from the speaker. Keep the blade of the R-3000 PRO vertical and move slowly backwards and forwards over the cable or pipe, reducing the sensitivity for a narrower response. Use the meter deflection to aid pinpointing. Maximum meter deflection indicates the position of the conductor.

Trace the conductor out of the area, marking the position with chalk or paint.

**ALWAYS DIG WITH CAUTION.**

## Functional Test

- Set the G-3000 PRO to pulsed operation, switch on and place on the ground
- Check there is an audible sound from the speaker
- Place the R-3000 PRO flat on the ground and pointing toward the G-3000 PRO



With the sensitivity switched on and set to maximum sensitivity, check that the audio response (which should be synchronised with the G-3000 PRO audio output) as detailed in the table below.

Mode	Test Distance	Audio Output
Power	30cm (1ft)	Pulsed, clearly audible
Radio	1.5m (5ft)	Pulsed, clearly audible
Genny	15m (50ft)	Pulsed, very high volume
Avoidance	15m (50ft)	Pulsed, very high volume

## Mouse transmitters for non-metallic pipe location

These devices have relatively short battery lives. They should always be fitted with new batteries before use. Insert one battery and use a tested R-3000 PRO to confirm that the Mouse can be located at 4 metres. Remember that the R-3000 PRO blade must be in line with the Mouse which is the opposite to that which is normally used for pipe or cable locating.

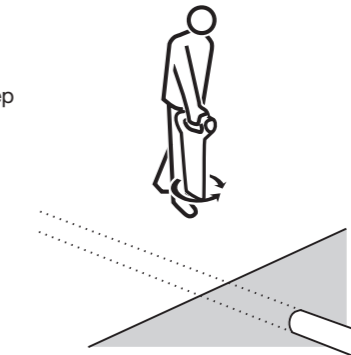

## Using Radio mode

Set the Function Switch to Radio.

Follow the same procedure as outlined in 'Using the Power mode'.

**WARNING**  
Increased risk of property damage, death, or serious injury may result if buried utilities, pipes, and cables are not properly located before digging.

Make sure to read and follow all instructions and warnings in the owner's guide when using the AT-3000 PRO.

The R-3000 PRO detects most buried cables and conductors, BUT SOME CABLES AND CONDUCTORS (EVEN LIVE ONES) DO NOT RADIATE SIGNALS, SO THE R-3000 PRO WILL NOT DETECT THEM. Also, the R-3000 PRO does not indicate whether a signal comes from a single cable or conductor or from several cables or conductors buried in close proximity to each other.

Even if using a AT-3000 PRO, ALWAYS DIG WITH CAUTION.

Call your local support number (available from [www.radiodetection.com](http://www.radiodetection.com)) for questions regarding the proper use, maintenance, and repair of the R-3000 PRO and Genny<sup>®</sup>.

## Locating with the AT-3000 PRO

The G-3000 PRO is used to apply a tone to a buried conductor. This signal can be traced using the R-3000 PRO locator switched to the Genny mode.

### Direct Connection

Direct connection is an efficient form of signal application and is suitable for connection to a valve, meter, junction box or other access point.

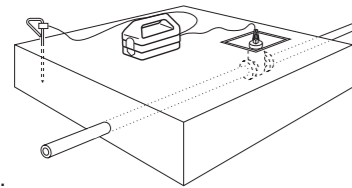

**WARNING**  
Connection to a power cable sheath should only be undertaken by qualified personnel.

## Method

Decide if the G-3000 PRO is to be switched to pulse or continuous operation. As a guide, depth measurements are best done with a continuous signal. If battery power saving is an issue, switch to pulse operation. A pulsing signal may also be easier to detect as the signal gets weak towards the end of the trace length. The pulse/continuous switch is located on the underside of the G-3000 PRO.

Plug the connection lead into the G-3000 PRO connection socket and attach the red lead to the target line. If necessary, clean the connection point to ensure a good electrical contact. If the jaws of the clip do not open far enough, and the connection point is a ferrous material, use the magnet that is on the clip to attach it.

Clip the ground lead to the earth stake which should be placed in the ground 3 or 4 paces away from, and at right angles to the target line.

Alternatively the ground lead may be clipped to the rim of a valve box or manhole cover. Use the earth spool lead to extend the earth connection if necessary.

Switch the G-3000 PRO on. After an initial warble, a good connection is indicated by a drop in loudspeaker tone. If there is no tone or it is a very slow bleep, replace the batteries.

Switch the R-3000 PRO to G-3000 PRO mode (or AvoidanceScan™ if conducting a general sweep) and begin to trace the line from the point of application. Keep the blade of the R-3000 PRO vertical and across the probable direction of the line. Move slowly backwards and forwards over the conductor, reducing the sensitivity for a narrower response. Maximum audio and meter deflection will indicate the position of the target line.

When directly over the line and with the sensitivity level set for approximately ¼ deflection, rotate the R-3000 PRO on its axis until a signal minimum is found. The blade is now in line with the target line. Continue tracing the line as outlined above.

### Induction

Induction is a convenient and quick way of applying the G-3000 PRO signal to a pipe or cable where limited access does not permit direct connection or the use of a signal clamp.

Set the G-3000 PRO to pulse or continuous mode. Place the G-3000 PRO over the assumed position of the conductor and in the orientation shown.

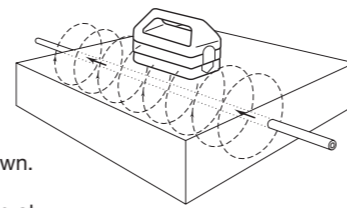

Start tracing the target line at least five paces from the G-3000 PRO with the R-3000 PRO set in the G-3000 PRO mode. Working too close to the G-3000 PRO may give false readings as the R-3000 PRO will detect radiated signals directly from the G-3000 PRO rather than the target line.

### Active search using Induction

Placing the G-3000 PRO on its side swamps an area with G-3000 PRO signal. Note that signal is not transmitted directly below the G-3000 PRO in this orientation, so repeat the exercise with the G-3000 PRO moved to the side by at least one metre.

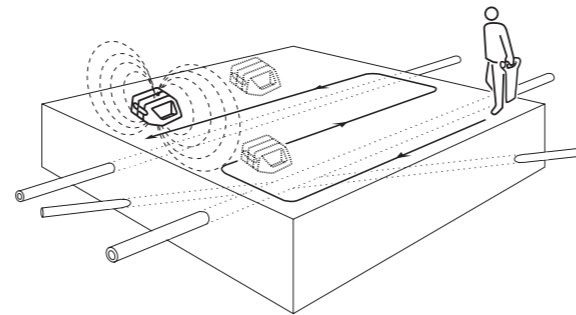

Alternatively, use a two man technique to search an area for buried utilities as shown.

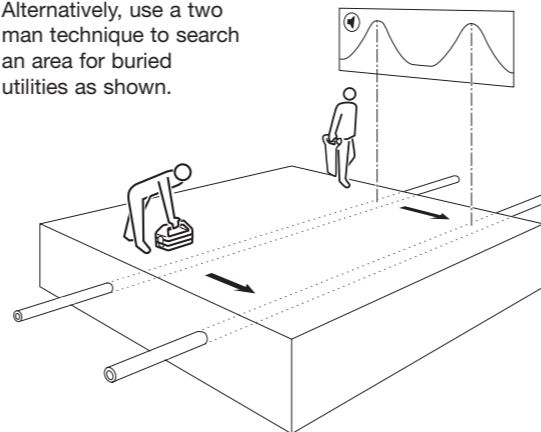

## Using the optional Signal Clamp

The Signal Clamp applies a Genny signal safely to a pipe or live cable up to 76mm (3 inches) diameter, without interrupting the supply.

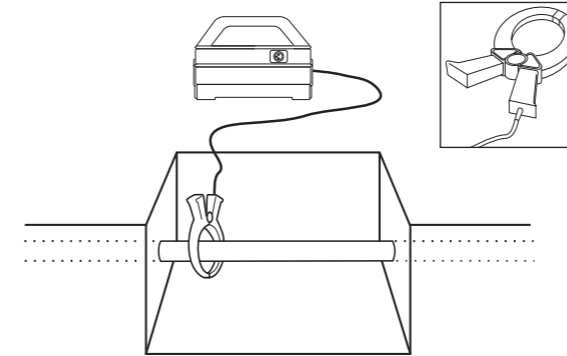

### Method

Plug the Clamp into the G-3000 PRO Connection socket.

Place the Clamp around the pipe or cable ensuring the jaws are closed. Switch the G-3000 PRO on. Open and close the Clamp. If the jaws are closing correctly there will be a change in tone as the jaws are closed.

An earth connection, from the G-3000 PRO, is not necessary but efficient signal transfer is only achieved if the target line is grounded at both ends. This is usually the case with power cables.

The Signal clamp can be used with the G-3000 PRO set to either pulse or continuous mode.

### Using the optional Mouse Signal Transmitter

The Mouse is a small self-contained watertight transmitter which can be detected by the R-3000 PRO when switched to the G-3000 PRO mode.

### Method

Unscrew the housing and insert the single LR6 or AA type alkaline battery in the orientation shown by the diagram in the battery compartment.

### Note

Placing the battery in the incorrect orientation will not harm the Mouse and is a good method of storing the battery when not in use.

Place the Mouse on the ground, set the R-3000 PRO to G-3000 PRO mode and, whilst holding the R-3000 PRO in line with the Mouse, check that the signal is being received.

Insert the Mouse approximately 1m/3yd into the duct or drain and adjust the R-3000 PRO sensitivity to receive the signal.

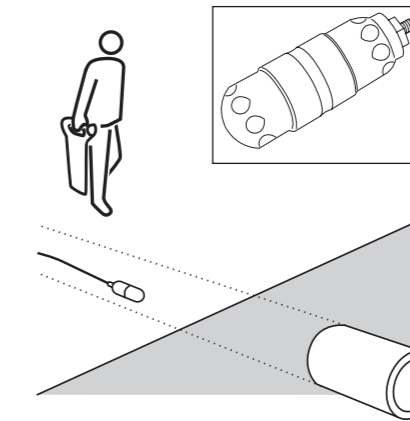

Smaller ghost signals appear before and behind the main signal position. Locate all three peaks to be sure the largest middle one is identified as the Mouse position.

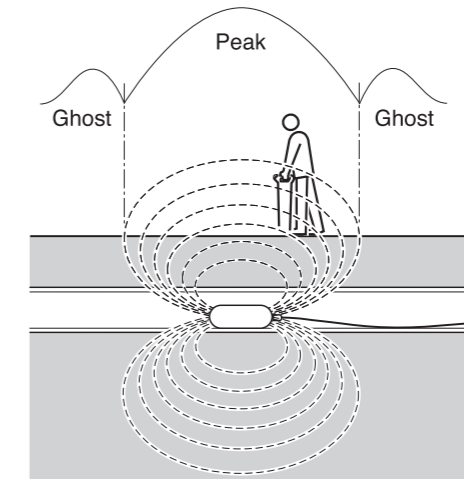

Rotating the R-3000 PRO about its axis to obtain the largest signal puts the blade of the R-3000 PRO in line with the Mouse and is a good way of identifying the direction of the duct or pipe.

### Taking line depth measurements using the AT-3000 PRO

For best accuracy use the G-3000 PRO in continuous mode (it is possible to perform depth measurements with the G-3000 PRO set to pulse mode but a slight reduction in accuracy may be experienced).

## Method

Locate the target line as described previously.

If using the G-3000 PRO in induction ensure that the depth measurement position is at least 30 paces from the G-3000 PRO. If using direct connection or a signal clamp, this distance can be reduced to approximately 5 paces.

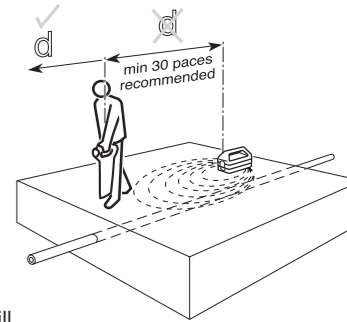

Hold the R-3000 PRO still, vertical and at right angles to the buried line. Momentarily depress the depth button. The display will show a moving clockface followed by the depth measurement.

### Taking Mouse depth measurements using the R-3000 PRO

Depth measurements are only possible when using the R-3000 PRO in the G-3000 PRO mode with a M-3000 transmitter, identified with a central orange band.

### Method

Locate the main Mouse signal as previously described. Hold the R-3000 PRO vertical and in line with the Mouse. Press and hold the depth button until 'M' appears on the display and then release. A clockface will appear in the top right hand corner of the display while the depth calculation is made. The approximate depth to the Mouse will then be displayed.

### Note

If the StrikeAlert™ feature is enabled the alarm will activate at approximately 1.2m when locating a sonde. If this is an inconvenience, the StrikeAlert™ feature can be disabled in the Genny mode by pressing and holding the depth button for the duration of the battery test bleep at switch on.

### Error messages

Flashing **---** indicates conductor out of range.

**---** indicates depth attempted in radio which is not allowed.  
**---** not possible to indicate depth eg, high interference.

**WARNING**  
Do not use the R-3000 PRO depth measurement to decide if mechanical digging over a buried conductor is appropriate.