

P/N 975764
5/98

OPERATING INSTRUCTIONS for **AMPROBE**

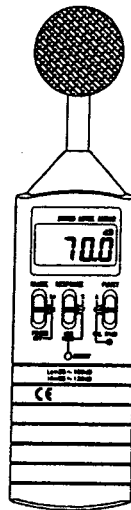

**SOUND LEVEL METER
MODEL SM-70**

 **AMPROBE®**
A United Dominion Company

I. LIMITED WARRANTY

Congratulations! You are now the owner of an AMPROBE product. It has been crafted according to the highest standards of quality and workmanship. This instrument has been inspected for proper operation of all of its functions and tested by qualified factory technicians according to the long-established standards of AMPROBE.

Your AMPROBE product had a limited warranty against defective materials and/or workmanship for one year from the date of purchase provided the seal is unbroken or, in the opinion of the factory, the instrument has not been opened, tampered with, or taken apart.

Should your instrument fail due to defective materials and/or workmanship during the one-year warranty period, return it along with a copy of your dated bill-of-sale which must identify the instrument by model number and manufacturer number.

Manufacturer number is located on inside of battery door.

IMPORTANT: For your protection, please use the instrument as soon as possible. If damaged, or should the need arise to return your instrument, place it in a shipping carton packed with sufficient packing material. It must be securely wrapped. Amprobe is not responsible for damage in transit. Be sure to include a packing slip (Indicating model and manufacturer number) along with a brief description of the problem. Make certain your name and address appears on the box as well as packing slip.

Ship prepaid via Air Parcel Post insured or u.p.s. (Where available) to:

Service Division

AMPROBE

630 Merrick Road (use for U.P.S.)

P.O.BOX 329 (use for Parcel Post)

Lynbrook, NY 11563-1329

Outside the U.S.A the local Amprobe representative will assist you. Above limited warranty covers repair and replacement only and no other obligation is stated or implied.

II. GENERAL DESCRIPTION AND FEATURES

Thank you for selecting our Sound Level Meter. To ensure that you can get the most from it, we recommend that you read and follow the manual carefully before use.

This unit was designed according to the IEC651, ANSI S1.4 for Sound Level Meters.

The SM-70 (Sound Level Meter) has been designed to meet the measurement requirements for Industrial safety offices and sound quality control in various environments.

- Ranges from 35dB to 130dB at frequencies between 31.5Hz and 8KHz.
- Display with 0.1dB steps on a 4-digits LCD.
- With two weighting, A and C.
- Both AC and DC signal output is available from a single standard 3.5mm coaxial socket suitable for a frequency analyzer, level recorder, FFT analyzer, graphic recorder; etc.

III. SPECIFICATIONS

Standard applied	: According to IEC651, ANSI S1. 4
Frequency range	: 31.5Hz ~ 8KHz
Measuring level range	: 35~130dB
Frequency weighting	: A/C
Microphone	: 1/2 inch Electric condenser microphone
Display	: LCD
Digital display	: 4 digits Resolution: 0.1dB Display period: 0.5 sec.
Time weighting	: FAST (125mS), SLOW (1 sec.)
Level ranges	: Lo: 35~100dB and Hi: 65~130dB
Accuracy	: ± 2.0 dB (under reference conditions)
Dynamic range	: 65dB
Alarm function	: " OVER " is show when input is out of range.
Maximum hold	: Hold readings, with decay < 1dB/3minutes.
Calibration	: Electrical calibration with the internal oscillator (1KHz sine wave)

AC output	: 0.65 Vrms at FS (full scale), output impedance approx. 600 Ω
DC output	: 10mV / dB, output impedance approx. 100 Ω
Power supply	: One 9V battery MN1604
Power life	: Approx. 50hrs (alkaline cell)
Operating temperature	: 32 to 104°F (0 to 40°C)
Operating humidity	: 10 to 90%RH
Storage temperature	: 14 to 140°F (-10 to 60°C)
Storage humidity	: 10 to 75%RH
Dimensions	: 240 (L) \times 68 (W) \times 25 (H)mm
Weight	: 210g (including battery)
Accessories	: 9V battery, carrying case, screwdriver, instruction manual, 3.5 ϕ plug, windscreen.

IV. NOMENCLATURE AND FUNCTIONS

① Microphone

1/2 inch Electric Condenser microphone

② Display

Serves to display the sound pressure level (dB), over or under range "OVER", maximum hold data "MAX HOLD" and Low battery indicator "BT".

dB : Sound pressure level with 0.1dB resolution.

OVER: Shown when the range setting is too high (or low).

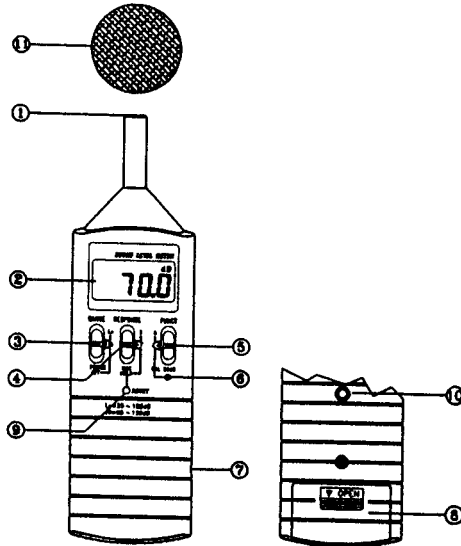

5

③ Power and Range switch

- Turn power ON and select measurement range.
(Hi range = 65~130dB, Lo range = 35~100dB)

- When "OVER" is indicated, slide range switch to another range for measurement.

④ Response and Max hold switch

Setting the meter dynamic characteristics (Fast/slow) and maximum value hold

S (slow response) : for comparatively stable noise measurement.

F (fast response) : for fast varying noise.

MAX HOLD : The max hold position is used to measure the maximum level of sounds. The maximum measured level is up dated continuously.

To RE-SET, set switch to "F" or "S" position to cancel existing value. Then, set switch to "MAX HOLD" position.

⑤ Function switch (A/C weighting & calibration selector)

A : A-weighting

C : C-weighting

CAL 94dB: Calibration

⑥ Calibration control can be adjusted clockwise or counterclockwise to standard 94.0dB.

6

⑦ Output jack

Standard 3.5mm 3 pole coaxial output socket.

Serves to supply AC signals and log-converted DC signals to external equipment.

OUTPUTS :

Two outputs can be accessed through 3.5mm stereo phone plug.

DC output : Logarithmic signal. 10mV/dB
impedance $\leq 100\Omega$

AC output : approx. 0.65 Vrms corresponding to each range step.
impedance $\approx 600\Omega$

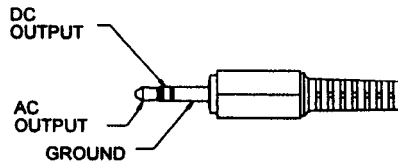

⑧ Battery cover (on bottom)

⑨ Reset button:

Serves to reset the maximum level indication.

⑩ Tripod mounting screw:

For long-term measurements, the unit can be mounted on a tripod. Use the tripod mounting screw provided on the bottom of the unit.

⑪ Windscreen:

Strong wind striking the microphone can cause a misreading. For measurements in windy locations, the windscreen should be used.

LCD display Description

① Sound Pressure Level measuring value, resolution 0.1dB.

② Measuring unit

③ When readout is out of range.

④ MAX HOLD: Maximum hold.

⑤ BT: Low battery indicator.

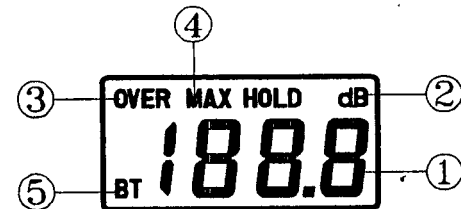

V. CALIBRATION PROCEDURES

(1). Using an acoustic calibrator

- a). Make the following switch settings.

RANGE : HI

RESPONSE : F

FUNCT : A

- b). Insert the microphone carefully into the insertion hole of the calibrator.

- c). Turn on the switch of calibrator and adjust the CAL screw of the instrument, until the level display indicates the desired level.

Note: Our products are well calibrated before shipment. Recommended calibrator cycle is one year.

(2). Calibration using the internal oscillator

- a). Make the following switch settings.

RANGE : HI

RESPONSE : F

FUNCT : A

- b). Adjust the unit to the readout.



VI. MEASUREMENT PREPARATION

(1). Battery Loading:

Remove the battery cover on the back and put in one 006p 9V Battery.

Note: make sure the battery polarity is correct.

(2). Battery Replacement:

When the battery voltage drops below the operating voltage, "BT" will appear in the display and, the battery should be replaced with a new one.

VII. OPERATING PRECAUTIONS

- (1). Wind blowing across the microphone would bring additional extraneous noise. When using the instrument in the presence of wind, it is a must to mount the windscreen in order to eliminate undesirable signals.

- (2). Calibrate the instrument before operation, if the instrument has not been in use for a long period of time or is operated in a bad environment.

- (3). Do not store or operate the instrument at high Temperature / Humidity environment for a long period.

- (4). Keep microphones dry and avoid severe vibration.

- (5). Take out the battery and keep the instrument in a low humidity environment when not in use.

VIII. MEASUREMENT

- (1). Open battery covers and install a 9-volt battery in the battery compartment.
- (2). Turn on power and select the desired response and weighting. If the sound source consists of short bursts or only catching sound peak, set RESPONSE to FAST. To measure average sound levels, use the slow setting.

Select A- weighting for general noise sound level and C weighting for measuring sound level of acoustic material.
- (3). Hold the instrument comfortably in hand or fix on tripod and point the microphone at the suspected noise source, the sound pressure level will be displayed.
- (4). When MAX HOLD mode is selected, the instrument captures and holds the maximum noise level for a long period.
Press " RESET" button to reset the maximum level indication.
- (5). Turn OFF the instrument when not in use.