



AD40B, AC40B

Mini Clamp Meters

Users Manual

**Test Equipment
Depot**

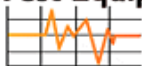

1-800-517-8431

99 Washington Street

Melrose, MA 02176

Fax 781-665-0780









TestEquipmentDepot.com

Mini Clamp Meters

Contents

Symbols.....	1
Warnings and Precautions	1
Introduction	2
Instrument Familiarization (Fig. 1)	2
AC Current Measurement (Fig. 2)	3
AC & DC Voltage Measurement (AC40B) (Fig. 3).....	3
Resistance & Continuity Measurement (AC40B) (Fig. 4).....	3
Display Hold.....	3
Specifications.....	3
Troubleshooting & Maintenance	5
Repair	6

Symbols

B	Battery		Refer to the manual
	Double insulated		Dangerous Voltage
	Direct Current		Earth Ground
~	Alternating Current		Audible tone
	Complies with EU directives		Application around and removal from hazardous, live conductors permitted

Warnings and Precautions

- **This instrument is EN61010-1:2001 and EN61010-2-32 certified for Installation Category III. It is recommended for use with local level power distribution, appliances, portable equipment, etc, where only smaller transient overvoltages may occur, and not for primary supply lines, overhead lines and cable systems.**
- **This instrument must not be used on uninsulated conductors at a voltage greater than 600V ac/dc.**
- **Use extreme caution when working around bare conductors and bus bars.**
- **Do not exceed the instrument overload limits per function (see specifications) nor the limits marked on the instrument.**
- **Exercise extreme caution when: measuring voltage >60 V DC or 30 V AC RMS // current >10 mA // AC power lines with inductive loads // AC power lines during electrical storms // servicing CRT equipment. High voltages can be lethal and high voltage transients may occur at any time.**
- **Never measure current while test leads are inserted in the input jacks.**

- **Always inspect your instrument, test leads and accessories for signs of damage or abnormality before every use. If abnormal conditions exist (broken or damaged test leads, cracked case, display not reading, etc.), do not use.**
 - **When making voltage measurements, make sure these ranges function correctly. Take a reading of a known voltage first.**
 - **Never ground yourself when taking measurements. Do not touch exposed metal pipes, outlets, fixtures, etc., which might be at ground potential. Keep your body isolated from ground and never touch exposed wiring, connections, test probe tips, or any live circuit conductors.**
 - **Do not operate the instrument in an explosive atmosphere (flammable gases, fumes, vapor, dust).**
 - **Do not use this or any piece of test equipment without proper training. Read the operating instructions before use and follow all safety instructions.**
 - **Use the meter only as specified in this manual; otherwise the meters safety circuitry may not protect you.**
 - **Use extreme caution when working around bare conductors. Contact with the conductor could result in electric shock.**
 - **The ridge at the top of the clamp body is intended to keep hands and fingers away from hazardous live conductors.**
-



Introduction

The AD40B is an average sensing and RMS (sine wave) indicating AC current clamp. The AC40B is an average sensing and RMS (sine wave) indicating AC current clamp meter that also measures AC and DC voltage, resistance and continuity.

Unpacking and Inspection

Your shipping carton should include the digital clamp meter, a carrying case, two 1.5 V AAA (UM-2) batteries (installed), and this manual plus one test lead set (one black, one red) for the AC40B meter. If any of the items are damaged or missing, return the complete package to the place of purchase for an exchange.

Instrument Familiarization (Fig. 1)

1. **Transformer Jaws:** Designed to pick up the AC current flowing through the conductor.
2. **Jaw Opening Lever:** Press lever to open transformer jaws. When pressure on lever is released, the jaws will close again.
3. **Selector Switch:** Turns instrument on and off and selects the measuring function.
4. **AC/DC selector switch (AC40B):** With the selector switch set to voltage measurement, this button selects between AC and DC voltage.
5. **Data Hold Switch:** Holds reading for all functions and ranges. Press again to release HOLD before taking a new measurement.
6. **Digital Display:** 3-3/4 digit LCD (max reading 3999) with decimal point, low battery , Auto-range, Data Hold , and unit indicators, plus, for the AC meter: AC~ , DC— , Polarity —) and continuity ).
7. **Input Terminals (AC meters):** Connect the black test lead to the “COM” input and red lead to the “+” input when measuring voltage, resistance and continuity (AC40B).

AC Current Measurement (Fig. 2)

1. Set the slide switch to AC~ position.
2. Open spring-loaded clamp by pressing lever on left side of meter.
3. Position clamp around wire or conductor and release clamp lever. Make sure that the conductor is centered in the clamp and that the clamp is entirely closed. The clamp must be positioned around only one conductor. If it is placed around two or more current carrying conductors, the reading is FALSE.
4. Read the measured value on the display. If the measured value exceeds the highest range for a period of time, overheating may occur. Interrupt measurement.

Note

Do not measure current on high-voltage conductors (>600 V) in order to avoid risk of discharge and/or incorrect reading.

AC & DC Voltage Measurement (AC40B) (Fig. 3)

1. Connect the black test lead to the COM input and the red test lead to the "+" input.
 2. Set the selector switch to V \cong position.
 3. Press the AC DC button to select AC or DC voltage (~ or \equiv is displayed).
 4. Connect probe tips to circuit, in parallel to the load.
 5. Read the measured value on the display.
-

Resistance & Continuity Measurement (AC40B) (Fig. 4)

1. Remove any voltage from resistance to be measured and discharge all capacitors.
2. Connect the black test lead to the COM input and the red test lead to the "+" input.
3. Set the selector switch to Ω \equiv position.
4. Connect the probe tips across the circuit or resistance.
5. Read the measured value on the display.

The instrument emits a continuous tone and the \equiv symbol is displayed when the measured resistance is < 40 Ω .

Display Hold

Press the HOLD button to keep the measured value on the display for later viewing. Press HOLD again to release the "Display Hold" function before taking a new measurement. Display Hold can be applied to all measuring functions.

Specifications

General Specifications

Display: (AC40B & AD40B) 3-3/4 digit LCD (max. reading 3999).

Polarity Indication: Automatic, negative indicated, positive implied

Overrange Indication : "OL" indicated.

Measuring Principle: Dual slope integration.

Range Selection: Automatic.

Low Battery Indication:  when battery voltage falls below operating voltage.

Auto Power Off (APO): Approx. 30 minutes after no function change.

Environmental Conditions

This instrument is designed for indoor use.

Altitude: < 2000 m

Operating Temperature: 0 °C to +40 °C, <80 % R.H., non-condensing.

Storage Temperature: -10 °C to +60 °C, <70 % R.H., non-condensing, batteries removed.

Power Supply: Two 1.5 V AAA batteries (UM-2).

Battery Life: Alkaline 300 hours, approx.

Maximum Jaw Opening: 25.4 mm.

Dimensions/Weight, AD40B (WxHxD): 64x190x36mm/250g (incl. battery).

Dimensions/Weight, AC40B (WxHxD): 64x190x36mm/280g (incl. battery).

Accessories: Manual, carrying case, test leads (AC40B).

Replacement Parts: Test lead set - TL245

Safety: meets EN 61010-1:2001 Cat III - 600V Pollution Degree: Level II,

EN 61010-2-032

EMC: meets EN61326-1.

Agency Approvals: 

This product complies with requirements of the following European Community Directives: 89/336/EEC (Electromagnetic Compatibility) and 73/23/EEC (Low Voltage) as amended by 93/68/EEC (CE Marking).

However, electrical noise or intense electromagnetic fields in the vicinity of the equipment may disturb the measurement circuit.

Measuring instruments will also respond to unwanted signals that may be present within the measurement circuit. Users should exercise care and take appropriate precautions to avoid misleading results when making measurements in the presence of electronic interference.

Electrical Specifications

Accuracy is $\pm(\% \text{reading} + \text{nbr digits})$ at 23 °C ± 5 °C, <80 % R.H.

DC Voltage (AC40B)

Range	Accuracy	Resolution
400 V	$\pm(1.2 \% \text{rdg} + 5 \text{ dgt})$	0.1 V
600 V	$\pm(1.2 \% \text{rdg} + 5 \text{ dgt})$	1 V

Input Impedance: 1 M Ω

Overload Protection: 600 V rms

AC Voltage (AC40B)

Range	Accuracy (40-450 Hz)	Resolution
400 V	$\pm(1.5 \% \text{rdg} + 10 \text{ dgt})$	0.1 V
600 V	$\pm(1.5 \% \text{rdg} + 10 \text{ dgt})$	1 V

Input Impedance: 1 M Ω

Measuring method: Dual slope integration. Average Sensing, rms indication. Overload Protection: 600 V rms

AC Current (AC40B/AD40B)

Range	Accuracy (50/400 Hz)	Resolution
40 A	$\pm(2.0 \% \text{rdg} + 10 \text{ dgt})$	0.01 A
400 A	$\pm(2.0 \% \text{rdg} + 10 \text{ dgt})$	0.1 A

Overload Protection: 660 A Accuracies are specified for conductor centered in the jaw. If the conductor is not centered, an additional error of max 1.5 % can result.

Measuring method: Dual slope integration. Average Sensing, rms indication.

Resistance (AC40B)

Range	Accuracy	Resolution
400 Ω	$\pm(1.0\% \text{rdg} + 5 \text{dgt})$	0.1 Ω

Max open circuit voltage, AC40B: -1.2 V nominal

Overload Protection, AC40B: 600 Vrms

Audible Continuity (AC40B)

Like resistance measurement. Continuous tone and  display at $R \leq 40 \Omega$ for AC40B

Max open circuit voltage: -1.2 V

Overload Protection: 600 Vrms

Data Hold: Hold display reading for all functions and ranges. Always remember to release Data Hold when taking a new measurement.

Troubleshooting & Maintenance

In case of malfunction during the operation of the meter, the following steps should be performed in order to isolate the cause of the problem:

1. Check the batteries.
2. Review the operating instructions for possible mistakes in operating procedure.
3. Check clamp against a known current source.
4. Check test leads for continuity (voltage and resistance).

Except for the replacement of the batteries, repair of the clamp should be performed only by a Factory Authorized Service Center or by other qualified instrument service personnel.

Front panel and case can be cleaned with a mild solution of detergent and water. Apply sparingly with a soft cloth and let dry completely before using. Do not use aromatic hydrocarbons or chlorinated solvents for cleaning.

Battery Replacement

The meter is powered by two 1.5 V AAA batteries. Replace batteries as soon as  symbol is displayed.

1. Turn meter off. Disconnect and remove the test leads.
2. Position the meter face down. Remove the two screws and lift off rear case.
3. Replace the batteries.
4. Reassemble the case.

1 Clamp Meter

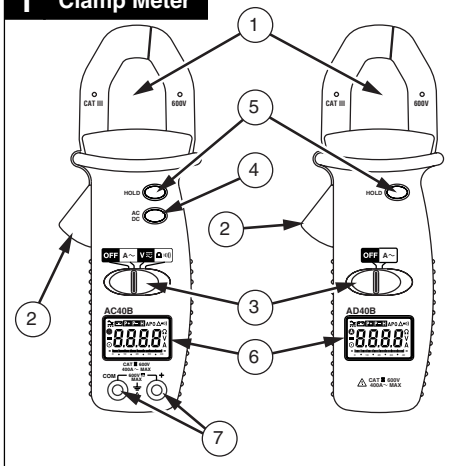

2 \tilde{A} Current

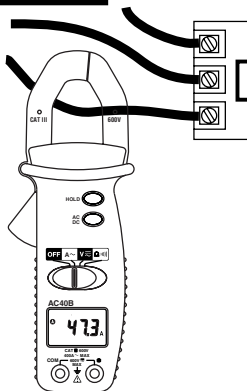

3 \bar{V} \tilde{V}

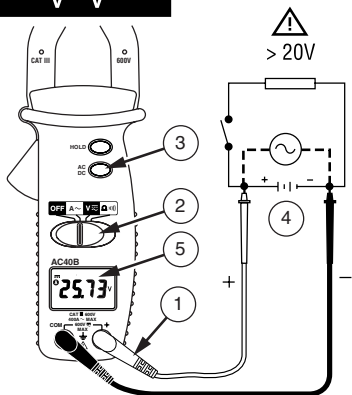

4 Ω \sim)

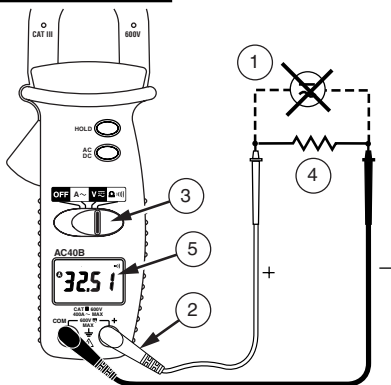

5

