

temperature

JOFRA™

Wide temperature range

ATC-156	-24 to 155°C (-11 to 311°F)
ATC-157	-45 to 155°C (-49 to 311°F)
ATC-320	33 to 320°C (91 to 608°F)
ATC-650	33 to 650°C (91 to 1202°F)

Improved temperature homogeneity

Unique dual-zone block ensures good temperature homogeneity in the critical calibration zone

High accuracy

Using the internal reference or the external reference sensor. 4-wire True-Ohm-Measurement technology is used

Enhanced stability

MVI circuitry ensures temperature stability despite mains supply variations

Cost effective calibration system

Stand-alone operation eliminates the need for secondary equipment and PC. Universal inputs handle multiple type temperature sensors

Timesaving features

Up- and download complete calibration tasks. Auto-stepping, switch testing and many more features make the daily use smooth and fast

Documentation made easy

RS232 communication and JOFRACAL calibration software are included in the standard delivery

Complete marine program

Part of a complete program of marine approved temperature, pressure and signal calibrators; including temperature sensors

ISO 9001 Manufacturer

Model ATC-156/157/320 and 650 Advanced Temperature Calibrator

PRODUCT DESCRIPTION

The JOFRA ATC series (Advanced Temperature Calibrators) combines the accuracy of laboratory temperature sources with the speed and portability of field dry-block calibrators.

The unique dual-zone design sets new standards for optimum temperature performance in dry-block calibrators.



Features

The JOFRA ATC-156/157/320 and 650 all features the unique dual-zone heating block - designed for optimum performance and superior temperature homogeneity throughout the block. This new design has a performance equivalent to a liquid temperature bath. The ATC-157 features the widest temperature range for a cooling dry-block on the market today.

Each ATC dry-block calibrator may be used to perform fully automatic calibration routines without using an external computer. Use the computer for full upload and download capabilities. Units may also be supplied with inputs for external reference sensors and for sensors-under-test. All ATC calibrators feature RS232 serial communication and standard delivery also includes the JOFRACAL calibration PC software.

The ATC-156/157/320 and 650 dry-block calibrators are part of a series of calibrators, that also includes the ATC-140 (-20 to 140°C) and the ATC-250 (28 to 250°C) available as liquid bath or large diameter dry-block calibrators.

See more about the ATC-140 and ATC-250 calibrators at page 5 or in specification sheet SS-CP-2284 at www.jofra.com

AMETEK®
CALIBRATION INSTRUMENTS

Unique temperature performance

The ATC series of calibrators provide precision temperature calibration of sensors; whatever the type or format. This is accomplished through an innovative dual-zone heating technology.

The JOFRA ATC-156/157/320 and 650 all feature a dual-zone heating technology. Each heating zone is independently controlled for precision temperature calibration. The homogeneity in the lower part is close to that of a laboratory liquid bath. The lower zone ensures optimum heat dissipation throughout the entire calibration zone. The upper zone compensates for heat loss from the sensor-under-test and from the open top. This design also eliminates the need for insulation of the sensors-under-test and makes it possible to calibrate liquid-filled and other mechanical sensors.

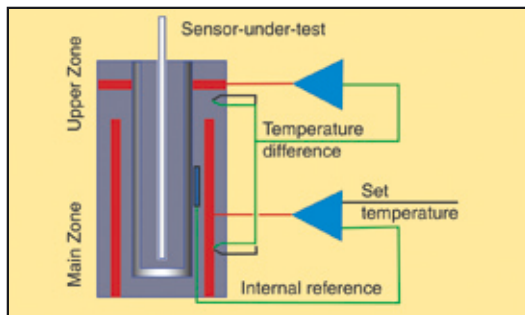

ATC heating and cooling models

The models with both heating and cooling capabilities (ATC-156 and ATC-157) feature the Peltier element multi-stage-technology. This both improves efficiency and extends the life of the »electronic heat pump«. The JOFRA ATC-157 offers a typical differential temperature of 68C (122 F) below the ambient temperature.

Peltier effect (ATC-156 and -157)

In 1834, Jean Peltier, a French physicist found that an "opposite thermocouple effect" could be observed when an electric current was connected to a thermocouple. Heat would be absorbed at one of the junctions and discharged at the other junction. This effect is called the "PELTIER EFFECT".

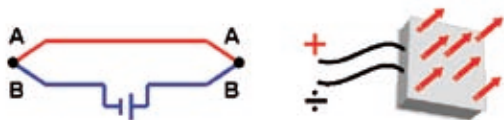

The practical Peltier element (electronic heating pump) consists of many elements of semiconductor material connected electrically in series and thermally in parallel. These thermoelectric elements and their electrical interconnections are mounted between two ceramic plates. The plates serve to mechanically hold the overall structure together and to electrically insulate the individual elements from one another.

MVI - Improved temperature stability

MVI stands for "Mains power Variance Immunity".

Unstable mains power supplies are a major contributor to on-site calibration inaccuracies. Traditional temperature calibrators often become unstable in production environments where large electrical motors, heating elements, and other devices are periodically cycled on or off. The cycling of supply power can cause the temperature regulator to perform inconsistently leading to both inaccurate readings and unstable temperatures.

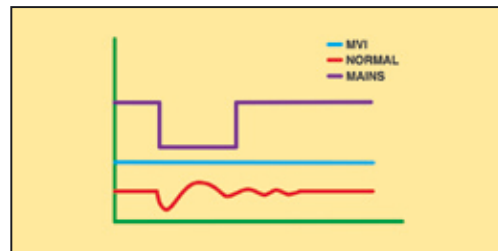

The JOFRA ATC-320 and ATC-650 calibrators employ the MVI, thus avoiding such stability problems. The MVI circuitry continuously monitors the supply voltage and ensures a constant energy flow to the heating elements. The JOFRA ATC-156 and ATC-157 models run on stabilized DC voltage and thus do not need the MVI circuitry.

Highest accuracy (model B only)

ATC series calibrators may be supplied with a built-in reference thermometer for use with an external sensor. This feature allows one instrument to provide the freedom and flexibility to perform calibrations at the process site while maintaining a high accuracy.

A special 90° angled external reference sensor has been designed to accommodate sensors with a transmitter head, top connector or similar arrangement.

The user can decide whether to read the built-in reference sensor or the more accurate angled reference sensor from the calibrator's large, easy-to-read LCD display. The external sensor and the internal sensor are independent of one another. Downloading of reference sensor linearization is done via a personal computer.

Please find more information about JOFRA STS reference sensors in specification sheet: SS-CP-2290 at www.jofra.com.

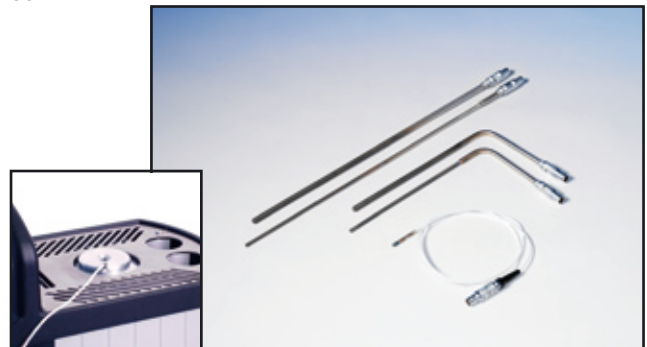

SET-Follows-TRUE (model B only)

Available on B models only, the “SET-Follows TRUE” makes the instrument tune in until the temperature of the external reference “TRUE” meets the desired “SET” temperature. This is used when it is critical that the temperature of the calibration zone matches the desired temperature when measured with accurate external reference sensors.

This feature is ideal when calibrating gas correctors or other custody transfer applications. It is also extremely useful to calculation procedures.

Reading of sensor-under-test (model B only)

The ATC series model B is equipped with built-in converters (inputs) that enables measurement of virtually any type of temperature sensor including:

- thermostats
- resistance thermometers (RTD)
- thermocouples (TC)
- transmitters
- milliamps (mA)
- voltage (V)

The ATC calibrators can be user-programmed for completely automated temperature calibrations. Once the unit is programmed, the instrument operates itself by performing the configured calibration routine. All calibration data is stored and available for uploading and generating exact calibration certificates or reports.

Switch test (model B only)

Users may perform a thermostatic test and find “Open”, “Closed” and the hysteresis (deadband) automatically. The instrument retains the last five tests.

Auto-stepping

Up to 20 different temperature steps may be programmed including the hold time for each step. Upon completion of an auto step routine, the user can easily read the results for the sensor-under-test. Up to five (5) auto step results are stored.

AUTO STEP SETUP			
 No. of steps: 5 Mode: One-way Hold time: 5 min	T1	0°C	T11 °C
	T2	100°C	T12 °C
	T3	200°C	T13 °C
	T4	300°C	T14 °C
	T5	400°C	T15 °C
	T6	°C	T16 °C
	T7	°C	T17 °C
	T8	°C	T18 °C
	T9	°C	T19 °C
	T10	°C	T20 °C
Back-space		Prev. field ▲	Next field ▼

Easy-to-use, intuitive operation

All instrument settings can be performed from the front panel. The heat source is positioned away from the panel which helps protect the operator.

The ATC keyboard is equipped with five, positive feedback function keys. They correspond to the text in the display and change functionality based on instrument operations. There are also dedicated function keys with permanent functions.

The easy-to-read, backlit display is large with a high contrast that is readable even in high ambient light conditions. The display is easily read from all angles and from a distance without parallax problems. The display also features icons which help identifying instrument conditions and operational steps, making it more intuitive to work with.



Set temperature

The “Set temperature” feature allows the user to set the exact desired temperature with a resolution of 0.01°.

Enhanced stability

A stability indicator shows when the ATC calibrator has reached the desired temperature and is stable. The user may change the stability criteria, external reference and the sensor-under-test quickly and simply. The stability criteria is the user’s security for a correct calibration. A count-down timer is displayed next to the temperature read-out.

Instrument setups

The ATC series allows the user to store up to nine (9) complete instrument setups. You may store all sorts of information including temperature units, stability criteria, use of external reference sensor, resolution, sensor-under-test (SUT), conversion to temperature, display contrast, etc. The setup may be recalled at any time.

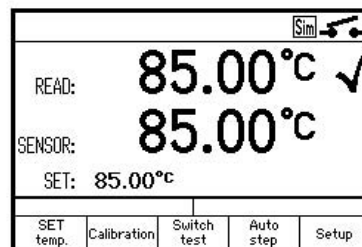

Maximum temperature

From the setup menu, the user can select the maximum temperature limit for the calibrator. This function prevents damage to the sensor-under-test caused by the application of excessive temperatures. The feature also aids in reducing drift resulting from extended periods of exposures to high temperatures. This feature can be locked with an access code.

JOFRACTAL CALIBRATION SOFTWARE

JOFRACTAL calibration software ensures easy calibration of RTD's, thermocouples, transmitters, thermoswitches, pressure gauges and pressure switches. JOFRACAL can be used with JOFRA DPC-500, APC, CPC and IPI pressure calibrators, all JOFRA temperature calibrators, as well as JOFRA AMC900, ASC300 multi signal calibrator and ASM-800 signal multi scanner.

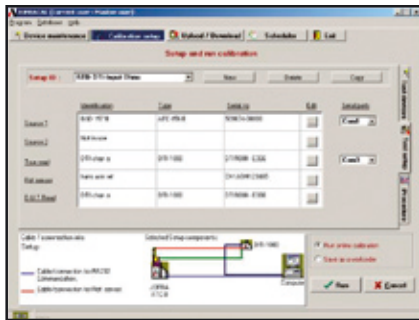

JOFRACTAL calibration software may also be used for manual calibrations, as it can be set up to accept manual entry of calibration data together with other liquid baths, ice points or dry-block heat sources.

The calibration data collected may be stored on a PC for later recall or analysis. The ATC calibrator stores the calibration procedure and may be taken out to the process site without using a personal computer.

This allows the ATC calibrator to:

- Operate as a stand-alone instrument, using advanced calibration routines without the assistance of a personal computer on site;
- Prevent unauthorized changes to a calibration routine. Personnel who are not authorized to alter a calibration routine cannot do so.

Once all calibrations are completed, the data may be uploaded to the JOFRACAL calibration software for post-processing and printing of certificates. The calibration data collected may be stored on the personal computer for later recall or analysis.

The JOFRACAL temperature calibration software may be downloaded free of charge from our web-page www.jofra.com.

Please also see more about JOFRACAL calibration software in specification sheet SS-CP-2510, which can be found at www.jofra.com

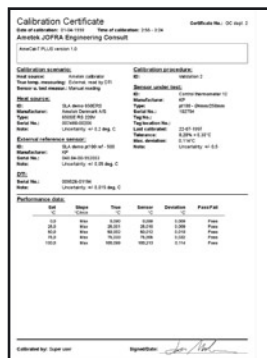

As found/as left (model B only)

The JOFRA ATC series calibrator automatically handles "As Found/As Left" calibrations. The calibrator stores both results. The first performed calibration is "As found" and the last performed calibration is the "As left", regardless of the number of calibrations/adjustments that may have been made in between.

SYNC output

An output is located directly on the front of the ATC calibrator. This output signals when the instrument is stable and may be used with ancillary devices such as video recorders, digital cameras or as an input to a data logging device. The SYNC output may be useful for automating and documenting your calibrations when calibrating external reading devices.

Calibration (model B only)

Users may perform or read the results of the calibration tasks directly on the instrument. When calibrating an indicating device, users may key in the results during or after the test. Using the "Calibration info" function, the user may view the complete calibration task, including the "Scenario" before the calibration takes place.

Calibration of up to 24 sensors with JOFRA ASM

Using the JOFRA ATC series together with the ASM Advanced Signal Multi-scanner offers a great time-saving automatic solution to calibrate multiple temperature sensors at the same time. The ASM series is an eight channel scanner controlled by the JOFRACAL software on a PC. Up to 3 ASM units can be stacked to calibrate up to 24 sensors at the same time. It can handle signals from 2-, 3- and 4 wire RTD's, TC's, transmitters, thermistors, temperature switches and voltage.

Please also see more in specification sheet SS-CP-2360, which can be found at www.jofra.com

JOFRACTAL software

Minimum hardware requirements for JOFRACAL calibration software.

- INTEL™ 486 processor
- (PENTIUM™ 800 MHz recommended)
- 32 MB RAM (64 MB recommended)
- 80 MB free disk space on hard disk prior to installation
- Standard VGA (800 x 600, 16 colors) compatible screen
- (1024 x 786, 256 colors recommended)
- CD-ROM drive for installation of the program
- 1 free RS232 serial port

FUNCTIONAL COMPARISON

ATC series		ATC-125 A	ATC-125 B	ATC-140 A	ATC-140 B	ATC-156 A	ATC-156 B	ATC-157 A	ATC-157 B	ATC-250 A	ATC-250 B	ATC-320 A	ATC-320 B	ATC-650 A	ATC-650 B
Temperature range @ ambient 23°C / 73°F															
-90 to 125°C	-130 to 257°F	X	X												
-20 to 140°C	-4 to 284°F			X	X										
-24 to 155°C	-11 to 311°F					X	X								
-45 to 155°C	-49 to 311°F							X	X						
28 to 250°C	82 to 482°F									X	X				
33 to 320°C	91 to 608°F											X	X		
33 to 650°C	91 to 1202°F													X	X
Temperature stability															
±0.01°C	±0.018°F					S	S	S	S			S	S		
±0.02°C	±0.036°F			X	X					X	X			S	S
±0.03°C	±0.054°F	X	X												
Accuracy incl. external STS reference sensor															
±0.04°C	±0.07°F			X ¹		X ¹		X ¹							
±0.06°C	±0.11°F	X	X												
±0.07°C	±0.13°F									X ¹		X ¹			
±0.11°C	±0.2°F														X ¹
Accuracy with internal reference sensor															
±0.10°C	±0.18°F					S	S								
±0.13°C	±0.23°F							S	S						
±0.18°C	±0.32°F			S	S										
±0.20°C	±0.36°F											S	S		
±0.28°C	±0.50°F									S	S				
±0.30°C	±0.54°F	X	X												
±0.35°C	±0.63°F													S	S
Immersion depth															
185 mm	7.3 in	X	X												
180 mm	7.1 in			X ²	X ²										
160 mm	6.3 in					X	X	X	X						
150 mm	5.9 in			X ³	X ³					X ⁴	X	X	X	X	X
Insertion tube diameter															
63.5 mm	2.5 in			X	X					X	X				
30 mm	1.2 in	X	X			X	X					X	X	X	X
20 mm	0.8 in							X	X						

	Model A	Model B
Dual-zone heating/cooling block	•	•
MVI - Mains Variance Immunity (or similar)	•	•
Stability indicator	•	•
Automatic step function	•	•
JOFRACAL Calibration software included as standard	•	•
SYNC output (for external recording device)	•	•
Display resolution 0.01°	•	•
Programmable max. temperature	•	•
Input for RTD, TC, V, mA		•
4-20 mA transmitter input incl. 24 VDC supply		•
All inputs scalable to temperature		•
Automatic switch test (open, close and hysteresis)		•
External precision reference sensor input		•
Download of calibration work orders from PC		•
Upload of calibration results (as found & as left)		•
"SET" follows "TRUE"		•

JOFRA ATC-140/250



For a wider product description of the ATC-140 and ATC-250 please see spec. sheet SS-CP-2284 at www.jofra.com

JOFRA ATC-125



For a wider product description of the ATC-125 please see spec. sheet SS-CP-2282, at www.jofra.com

X = Delivered as standard

S = Improved specifications (from October 01, 2006)

- ¹ Using an external STS reference sensor connected to the reference sensor input
- ² Immersion depth for ATC-140 as dry-block
- ³ Immersion depth for ATC-140 as liquid bath
- ⁴ Immersion depth for ATC-250 as dry-block and as liquid bath

FUNCTIONAL SPECIFICATIONS

Mains specifications

ATC-156/157/320..... 115V(90-127) / 230V(180-254)
 ATC-650 115V(100-127) / 230V(200-254)
 Frequency, non US deliveries 50 Hz ±5, 60 Hz ±5
 Frequency, US deliveries 60 Hz ±5
 Power consumption (max.) ATC-156/157 300 VA
 Power consumption (max.) ATC-320/650 1150 VA

Temperature range

ATC-156 Maximum 155°C / 311°F
 Minimum @ ambient temp. 0°C / 32°F -40°C / -40°F
 Minimum @ ambient temp. 23°C / 73°F -24°C / -11°F
 Minimum @ ambient temp. 40°C / 104°F -12°C / 10°F
 ATC-157 Maximum 155°C / 311°F
 Minimum @ ambient temp. 0°C / 32°F -57°C / -71°F
 Minimum @ ambient temp. 23°C / 73°F -45°C / -49°F
 Minimum @ ambient temp. 40°C / 104°F -31°C / -24°F
 ATC-320 33 to 320°C / 91 to 608°F
 ATC-650 33 to 650°C / 91 to 1202°F

Stability

ATC-156/157 +0.01°C / +0.018°F 1) 2)
 ATC-320 +0.01°C / +0.018°F 1)
 ATC-650 (@100°C / 212°F) +0.01°C / +0.018°F 1)
 ATC-650 (@320°C / 608°F) +0.015°C / +0.027°F 1)
 ATC-650 (@650°C / 1202°F) +0.02°C / +0.036°F 1)

Measured after the stability indicator has been on for 10 minutes (ATC-156/157/320 and 650). Measuring time is 30 minutes.

- 1) Improved specifications (from October 1, 2006)
- 2) ± 0.015°C @ set temp. ambient ±3°C

Time to stability (approximate)

ATC-156 7 minutes
 ATC-157 6 minutes
 ATC-320/650 10 minutes

Accuracy (model B) with external STS reference sensor

ATC-156/157 B +0.04°C / +0.07°F
 ATC-320 B +0.07°C / +0.13°F
 ATC-650 B +0.11°C / +0.20°F

12 month period. Relative to reference standard. Specifications by use of the external JOFRA STS-100 reference sensor

Accuracy (model A+B) with internal reference sensor

ATC-156 A+B +0.10°C / +0.18°F 1)
 ATC-157 A+B +0.13°C / +0.23°F 1)
 ATC-320 A+B +0.20°C / +0.36°F 1)
 ATC-650 A+B (@320°C / 608°F) +0.30°C / +0.54°F 1)
 ATC-650 A+B (@650°C / 1202°F) +0.35°C / +0.63°F 1)

- 1) Improved specifications (from October 1, 2006)

Resolution (user-selectable)

All temperatures 1° or 0.1° or 0.01°

Radial homogeneity (difference between holes)

ATC-156/157 0.01°C / 0.02°F
 ATC-320 0.01°C / 0.02°F
 ATC-650 0.05°C / 0.09°F

Immersion depth

ATC-156/157 160 mm / 6.3 in
 ATC-320/650 150 mm / 5.9 in

Well diameter

ATC-156/320/650 30 mm / 1.18 in
 ATC-157 20 mm / 0.79 in

Heating time

ATC-156 -24 to 23°C / -11 to 73°F 4 minutes
 23 to 100°C / 73 to 212°F 9 minutes
 100 to 155°C / 212 to 311°F 10 minutes
 ATC-157 -45 to 23°C / -49 to 73°F 6 minutes
 23 to 100°C / 73 to 212°F 8 minutes
 100 to 155°C / 212 to 311°F 9 minutes
 ATC-320 50 to 320°C / 122 to 608°F 7 minutes
 ATC-650 50 to 320°C / 122 to 608°F 10 minutes
 50 to 650°C / 122 to 1202°F 27 minutes

Cooling time

ATC-156 155 to 100°C / 311 to 212°F 4 minutes
 100 to 23°C (212 to 73°F 9 minutes
 23 to 0°C / 73 to 32°F 6 minutes
 0 to -20°C / 32 to -4°F 13 minutes
 ATC-157 155 to 100°C / 311 to 212°F 3 minutes
 100 to 23°C / 212 to 73°F 6 minutes
 23 to 0°C / 73 to 32°F 3 minutes
 0 to -30°C / 32 to -22°F 9 minutes
 -30 to -45°C / -22 to -45°F 15 minutes
 ATC-320 320 to 100°C / 608 to 212°F 22 minutes
 100 to 50°C / 212 to 122°F 20 minutes
 ATC-650 650 to 100°C / 1202 to 212°F 43 minutes
 100 to 50°C / 212 to 122°F 25 minutes

SYNC output (dry contact)

Switching voltage Maximum 30 VDC
 Switching current Maximum 100 mA

INPUT SPEC'S (B MODELS ONLY)

All input specifications apply to the calibrator's dry-block running at the respective temperature (stable plus an additional 20 minutes period). Where the input measuring range is out of the calibrator's range, the SET temperature is either MIN. or MAX.

Transmitter supply

Output voltage 24VDC +10%
 Output current Maximum 25 mA

Transmitter input mA

Range 0 to 24 mA
 Accuracy (12 months) +0.01% Rdg. +0.015% F.S.

Voltage input VDC

Range: 0 to 12 VDC
 Accuracy (12 months) +0.005% Rdg. +0.015% F.S.

Switch input

Switch dry contacts
 Test voltage Maximum 5 VDC
 Test current Maximum 2.5 mA

RTD reference input (B models only)

Type.....4-wire RTD with true ohm measurements1)
F.S. (Full Scale) 350 ohm
Accuracy (12 months)±0.001% rdg. + 0.002% F.S.

RTD Type	Temperature		12 months	
	°C	°F	°C	°F
Pt100 reference	-50	-58	±0.020	±0.036
	0	32	±0.021	±0.038
	155	311	±0.023	±0.041
	320	608	±0.026	±0.047
	650	1202	±0.032	±0.058
	700	1292	±0.034	±0.061

Note 1: True ohm measurements are an effective method to eliminate errors from induced thermoelectrical voltages

RTD input

Type of RTD 2-wire
F.S. (range)..... 350 ohm or 2900 ohm
Accuracy (12 months)±0.005% rdg. + 0.005% F.S. + 50 m
Type of RTD 3- or 4-wire
F.S. (range)..... 350 ohm or 2900 ohm
Accuracy (12 months)±0.005% rdg. + 0.005% F.S.

RTD Type	Temperature		12 months	
	°C	°F	°C	°F
Pt1000	-50	-58	±0.046	±0.083
	0	32	±0.050	±0.090
	155	311	±0.061	±0.110
	320	608	±0.071	±0.127
	500	932	±0.087	±0.156
Pt500	-50	-58	±0.083	±0.149
	0	32	±0.087	±0.157
	155	311	±0.100	±0.180
	320	608	±0.111	±0.200
	500	932	±0.130	±0.235
Pt100	-50	-58	±0.054	±0.097
	0	32	±0.058	±0.104
	155	311	±0.069	±0.124
	320	608	±0.079	±0.142
	650	1202	±0.106	±0.191
	700	1292	±0.112	±0.202
Pt50 (only in Russian versions)	-50	-58	±0.098	±0.176
	0	32	±0.103	±0.185
	155	311	±0.116	±0.209
	320	608	±0.128	±0.230
	650	1202	±0.161	±0.290
Pt10	-50	-58	±0.453	±0.815
	0	32	±0.462	±0.831
	155	311	±0.495	±0.891
	320	608	±0.524	±0.943
	650	1202	±0.610	±1.098
	700	1292	±0.620	±1.116
Cu100	-50	-58	±0.050	±0.090
	0	32	±0.052	±0.094
	150	302	±0.060	±0.108
Cu50	-50	-58	±0.090	±0.162
	0	32	±0.093	±0.167
	150	302	±0.100	±0.180

If automatic cold junction compensation is used, the specification for CJ is ±0.40°C (±0.72°F).

Thermocouple input

Range 78 mV
F.S. (Full Scale) 78 mV
Accuracy (12 months)0.01% rdg. + 0.005% F.S.

TC Type	Temperature		12 months	
	°C	°F	°C	°F
E	-50	-58	±0.08	±0.14
	0	32	±0.07	±0.12
	155	311	±0.07	±0.12
	320	608	±0.08	±0.14
	650	1202	±0.11	±0.20
	1000	1832	±0.15	±0.28
J	-50	-58	±0.10	±0.17
	0	32	±0.08	±0.14
	155	311	±0.08	±0.15
	320	608	±0.10	±0.18
	650	1202	±0.12	±0.22
	1200	2192	±0.19	±0.34
K	-50	-58	±0.11	±0.20
	0	32	±0.10	±0.18
	155	311	±0.11	±0.20
	320	608	±0.12	±0.22
	650	1202	±0.16	±0.28
T	1372	2502	±0.28	±0.50
	-50	-58	±0.12	±0.22
	0	32	±0.10	±0.18
	155	311	±0.09	±0.16
	320	608	±0.09	±0.17
R	400	752	±0.10	±0.17
	-50	-58	±1.31	±2.35
	0	32	±0.78	±1.40
	155	311	±0.50	±0.90
	320	608	±0.42	±0.75
S	650	1202	±0.41	±0.74
	1760	3200	±0.50	±0.90
	-50	-58	±0.98	±1.77
	0	32	±0.78	±1.40
	155	311	±0.50	±0.90
B	320	608	±0.46	±0.83
	650	1202	±0.45	±0.81
	1768	3214	±0.52	±0.94
	250	482	±1.57	±2.83
	320	608	±0.99	±1.78
N	650	1202	±0.69	±1.23
	1820	3308	±0.48	±0.86
	-50	-58	±0.16	±0.29
	0	32	±0.15	±0.27
	155	311	±0.14	±0.24
XK (only in Russian versions)	320	608	±0.14	±0.25
	650	1202	±0.16	±0.28
	800	1472	±0.17	±0.31
	-50	-58	±0.07	±0.13
	0	32	±0.06	±0.11
U	155	311	±0.06	±0.12
	320	608	±0.07	±0.13
	650	1202	±0.11	±0.19
	800	1472	±0.12	±0.22
	-50	-58	±0.12	±0.21
U	0	32	±0.10	±0.18
	155	311	±0.09	±0.17
	320	608	±0.09	±0.17
	600	1112	±0.10	±0.19
	600	1112	±0.10	±0.19

PHYSICAL SPECIFICATIONS

Instrument dimensions (L x W x H)

All models 352 x 156 x 360 mm / 3.9 x 6.1 x 14.2 in

Instrument weight

ATC-156 12.2 kg / 26.9 lb
 ATC-157 13.1 kg / 28.9 lb
 ATC-320 10.2 kg / 22.5 lb
 ATC-650 12.1 kg / 26.7 lb

Insert dimensions

ATC-156 outer diameter 29,7 mm / 1.17 in
 ATC-156 inner diameter (multi hole) 25,9 mm / 1.02 in
 ATC-156 inner diameter (single hole) 22,0 mm / 0.87 in
 ATC-156 length 150 mm / 5.91 in
 ATC-157 outer diameter 19,9 mm / 0.78 in
 ATC-157 inner diameter 16,9 mm / 0.67 in
 ATC-157 length 150 mm / 5.91 in
 ATC-320/650 outer diameter 29,7 mm / 1.17 in
 ATC-320/650 inner diameter (multi hole) 25,9 mm / 1.02 in
 ATC-320/650 inner diameter (single hole) 22,0 mm / 0.87 in
 ATC-320/650 length 160 mm / 6.30 in

Weight of non-drilled insert (approximate)

ATC-156 290 g / 10.2 oz
 ATC-157 130 g / 4.6 oz
 ATC-320/650 940 g / 33.2 oz

Shipping (including optional carrying case)

ATC-156 22.2 kg / 48.9 lb
 ATC-157 23.1 kg / 50.9 lb
 ATC-320 20.7 kg / 45.6 lb
 ATC-650 22.6 kg / 49.8 lb
 Size: L x W x H. 659 x 309 x 514 mm / 26 x 12.2 x 20.2 in

Shipping (without carrying case)

ATC-156 16.5 kg / 36.4 lb
 ATC-157 17.4 kg / 38.4 lb
 ATC-320 15.0 kg / 33.1 lb
 ATC-650 16.9 kg / 37.2 lb
 Size: L x W x H. 570 x 235 x 440 mm / 22.4 x 9.3 x 17.3 in

Shipping (carrying case only)

Weight: 6.0 kg / 13.2 lb
 Size: L x W x H. 659 x 309 x 514 mm / 26 x 12.2 x 20.2 in

Miscellaneous

Serial data interface RS232 (9-pin male)
 Operating temperature 0 to 40°C / 32 to 104°F
 Storage temperature -20 to 50°C / -4 to 122°F
 Humidity 0 to 90% RH
 Protection class IP-10
 DNV Marine Approval, Certificate no A-10384

STANDARD DELIVERY

- ATC dry-block calibrator (user specified)
- Mains power cable (user specified)
- Traceable certificate - temperature performance
- Insert (user specified)
- Set of matching insulation plugs (4 mm OR 1/4 in hole for reference sensor)
- Tool for insertion tubes
- RS232 cable
- JOFRACAL calibration software
- AMETRIM-ATC software to adjust the ATC series
- User and reference manual

Model B instruments contain the following extra items:

- Test cables (2 x red, 2 x black)
- Traceable certificate - input performance

ACCESSORIES

- 125066 Extra fixture for sensor grip
- 125067 Extra sensor grip
- 122771 Mini-Jack Connector for stable relay output
- 120516 Thermocouple Male Plug - Type J - Black
- 120517 Thermocouple Male Plug - Type K - Yellow
- 120514 Thermocouple Male Plug - Type N - Orange
- 120515 Thermocouple Male Plug - Type T - Blue
- 120518 Thermocouple Male Plug - Type R / S - Green
- 120519 Thermocouple Male Plug - Type Cu-Cu - White
- 122801 Cable 0.5 m with LEMO / LEMO connectors
- 122823 2 m. Cable Female Banana to LEMO connection
- 125002 Edge port Converter with 4 pcs of RS232 ports
- 123374 Set of 3 pcs of insulation plugs
- 125510 Set of 3 pcs of insulation plugs / 1/4in ref. Hole

Heat shield (Optional) - 105496

External heat shield to be placed on top of the calibrator to reduce the hot air stream around the sensor-under-test. Especially important when testing thermocouples having head-mounted transmitters with cold-junction compensation.



Trolley (Optional) - 124315

A removable trolley for ATC carrying case 105805 ensures easy and safe transportation of the instrument. The protective carrying case ensures safe storage of the instrument and all associated equipment.



Support rod set (Optional) - 125068

Support rod for sensors to be mounted on all JOFRA dry-block calibrators. Holds the sensor under test in their position, while calibrating. Includes 2 sensors grips and 2 fixtures for sensor grips.

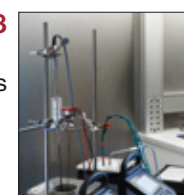

Calibration kit (Optional)

Includes a heat protection shield, cleaning brushes, 3 undrilled inserts with 4mm reference hole and a self-drilling guide. ATC-156: 122833, ATC-157: 123685, ATC-320/650: 122834

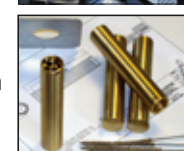

PREDRILLED INSERTS FOR ATC-156/157/320 AND 650 - 4 MM REFERENCE HOLE

JOFRA dry-block insert compatibility and materials:

ATC-320 = ATC-650 = ITC-320 = ITC-650 (made of brass)

ATC-155 = ATC-156 (made of aluminum)

ATC-157 = ITC-155 (made of aluminum)

All specifications on hole sizes are referring to the outer diameter (OD) of the sensor-under-test.

The correct clearance size is applied in all predrilled inserts.

Spare part no. for predrilled inserts with 4 mm reference hole				
Instruments				
Sensor diameter	Insert code ¹	ATC-155/156 A/B	ATC-157 A/B	ATC-320/650 A/B
3 mm	003	105623	123270	105622
4 mm	004	105625	123271	105624
5 mm	005	105627	123272	105626
6 mm	006	105629	123273	105628
7 mm	007	105631	123274	105630
8 mm	008	105633	123275	105632
9 mm	009	105635	123276	105634
10 mm	010	105637	123277	105636
11 mm	011	105639	123278	105638
12 mm	012	105641	123299 ²	105640
13 mm	013	105643	123300 ²	105642
14 mm	014	105645	N/A	105644
15 mm	015	105647	N/A	105646
16 mm	016	105649	N/A	105648
Package of the above inserts		124697	124699	124701
Set of insulation plugs for 4 mm reference hole		105810	123374	N/A

4 mm
Reference sensor



(ATC-157 A)

4 mm
Reference sensor

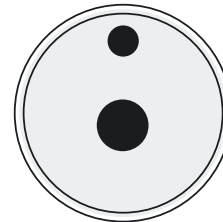

(ATC-156/320/650 A/B)

Spare part no. for predrilled inserts with 4 mm reference hole				
Instruments				
Sensor diameter	Insert code ¹	ATC-155/156 A/B	ATC-157 A/B	ATC-320/650 A/B
1/8 in	125	105677	123279	105676
3/16 in	187	105679	123280	105678
1/4 in	250	105681	123281	105680
5/16 in	312	105683	123282	105682
3/8 in	375	105685	123283	105684
7/16 in	437	105687	123301 ²	105686
1/2 in	500	105689	123302 ²	105688
9/16 in	562	105691	N/A	105690
5/8 in	625	105693	N/A	105692
Package of the above inserts		124698	124700	124702
Set of insulation plugs for 4 mm reference hole		105810	123374	N/A

Note: All inserts (metric and inches) are supplied with a hole for the 4 mm OD reference sensor.

Note 1: Use the insert code, when ordered as the standard insert together with a new calibrator.

Note 2: ATC-157: 12 mm, 13 mm, 7/16 in and 1/2 in inserts are delivered without the 4 mm reference hole, but supplied with a matching insulation plug.

APPLICATION KIT FOR CALIBRATION OF SANITARY SENSORS

At picture 1 you see a custom made insert and our STS-102 A cable reference sensor placed in a JOFRA ATC-156 B dry-block calibrator. At picture 2, the sanitary sensor has been fitted into the insert and is ready for calibration. Note that the design makes room for the reference sensor cable.

To learn more about calibration of sanitary temperature sensors please see accessory sheet AS-CP-2201 available at www.jofra.com



Picture 1



Picture 2



Application kit

PREDRILLED INSERTS FOR ATC-156/157/320 AND 650 - 1/4 IN REFERENCE HOLE

Spare part no. for predrilled inserts with 1/4 in (6.35 mm) reference hole				
		Instruments		
Sensor diameter	Insert code ¹	ATC-155/156 A/B	ATC-157 A/B	ATC-320/650 A/B
3 mm	803	125260	125290	125259
4 mm	804	125262	125291	125261
5 mm	805	125264	125292	125263
6 mm	806	125266	125293	125265
7 mm	807	125268	125294	125267
8 mm	808	125270	125295	125269
9 mm	809	125272	N/A	125271
10 mm	810	125274	N/A	125273
11 mm	811	125278	N/A	125277
12 mm	812	125280	123299 ²	125279
13 mm	813	125282	123300 ²	125281
14 mm	814	125284	N/A	125283
15 mm	815	125286	N/A	125285
Package of the above inserts		125389	125387	125388
Set of insulation plugs for 1/4 in (6.35 mm) ref. hole		125511	125510	N/A

1:1

1/4 in
Reference sensor



(ATC-157 A/B)

1/4 in
Reference sensor

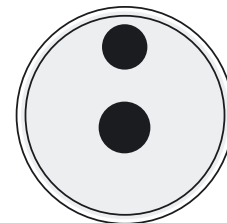

(ATC-156/320/650 A/B)

Spare part no. for predrilled inserts with 1/4 in (6.35 mm) reference hole				
		Instruments		
Sensor diameter	Insert code ¹	ATC-155/156 A/B	ATC-157 A/B	ATC-320/650 A/B
1/8 in	901	125297	125314	125296
3/16 in	902	125299	125315	125298
1/4 in	903	125301	125316	125300
5/16 in	904	125304	125317	125303
3/8 in	905	125306	N/A	125305
7/16 in	906	125308	123301 ²	125307
1/2 in	907	125310	123302 ²	125309
9/16 in	908	125312	N/A	125311
Package of the above inserts		125392	125390	125391
Set of insulation plugs for 1/4 in (6.35 mm) ref. hole		125511	125510	N/A

Note: All inserts (metric and inches) are supplied with a hole for the 1/4 in OD reference sensor.

Note 1: Use the insert code, when ordered as the standard insert together with a new calibrator.

Note 2: ATC-157: 12 mm, 13 mm, 7/16 in and 1/2 in inserts are delivered without the 1/4 in reference hole, but supplied with a matching insulation plug.

1:1

UNDRILLED INSERTS FOR ATC SERIES

Inserts, undrilled				
		Instruments		
Inserts		ATC-155/156 A/B	ATC-157 A/B	ATC-320/650 A/B
5-pack, undrilled inserts		122720	123286	122719
5-pack, undrilled inserts with a 4 mm hole for the reference sensor		122722	123285	122721
5-pack, undrilled inserts with a 1/4 in hole for the reference sensor		125288	125313	125287
Undrilled insulation plug		122781	123304	N/A

4 mm Reference sensor

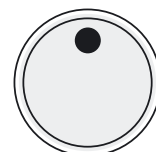

1/4 in Reference sensor

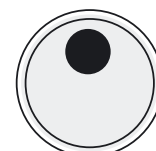

MULTI-HOLE INSERTS FOR ATC-156/157/320 AND 650 - METRIC (MM)

1:1

Spare part no. for multi-hole inserts - metric (mm)			
Insert code ¹	Instruments		
	ATC-155/156 A/B	ATC-157 A/B	ATC-320/650 A/B
M01	122751	123294	122750
M02	122753	123295	122752
M03	122755	123296	122754
M04	122757	N/A	122756
M06	N/A	125377	N/A
M07	N/A	125378	N/A
M08	N/A	125379	N/A

Note: All multi-hole inserts (metric and inches) for ATC-156/157 are supplied with a matching insulation plug.

Note: Remember to use matching insulation plugs.

Note 1: Use the insert code, when ordered as the standard insert together with a new calibrator.

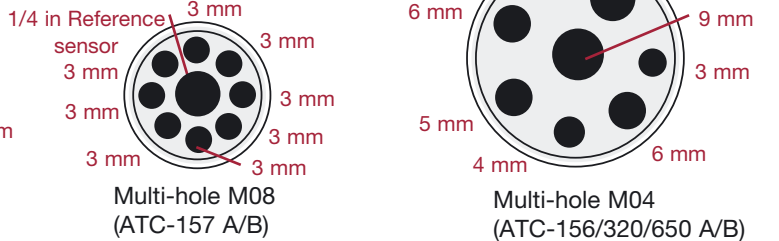
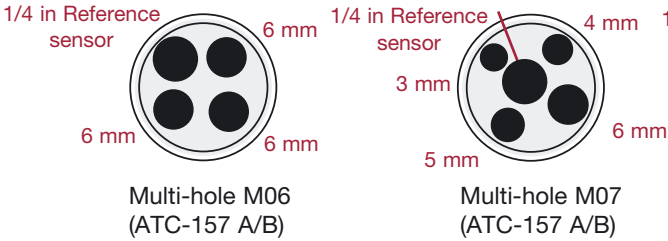
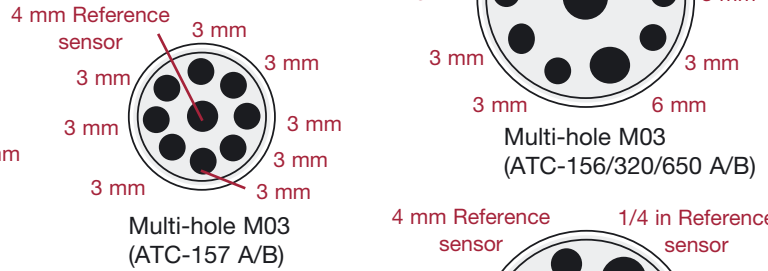
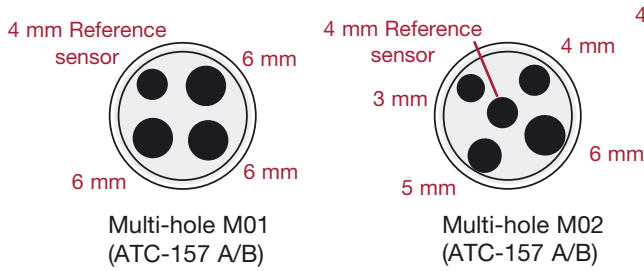
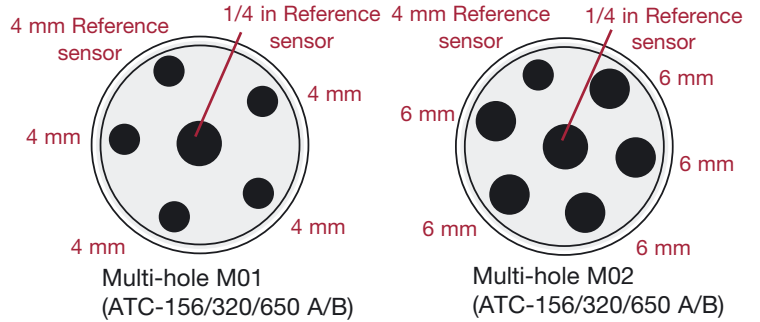

MULTI-HOLE INSERTS FOR ATC-156/157/320 AND 650 - IMPERIAL (INCH)

Spare part no. for multi-hole inserts - imperial (inch)			
Insert code ¹	Instruments		
	ATC-155/156 A/B	ATC-157 A/B	ATC-320/650 A/B
M04	N/A	123297	N/A
M05	122759	123298	122758
M06	122761	N/A	122760
M09	N/A	125380	N/A

Note: All multi-hole inserts (metric and inches) for ATC-156/157 are supplied with a matching insulation plug.

Note: Remember to use matching insulation plugs.

Note 1: Use the insert code, when ordered as the standard insert together with a new calibrator.

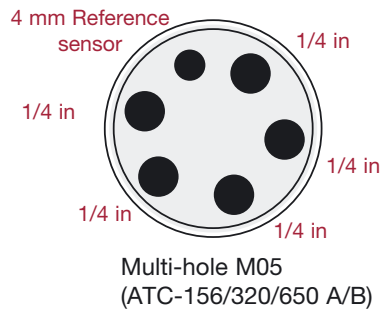

1:1

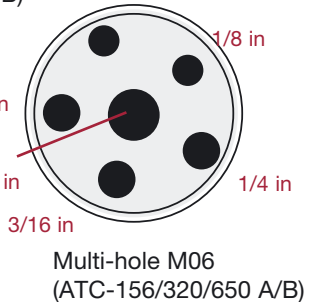
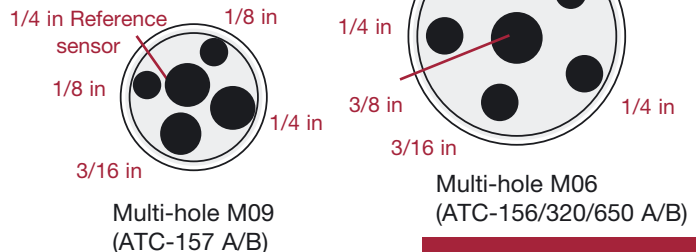
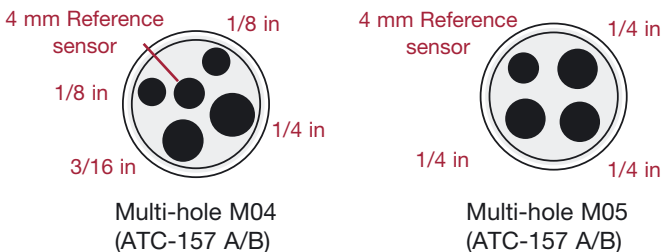

ORDERING INFORMATION

Order number	Description
ATC156	ATC-156 series, -23 to 155°C (-9 to 311°F)
ATC157	ATC-157 series, -45 to 155°C (-49 to 311°F)
ATC320	ATC-320 series, 33 to 320°C (91 to 608°F)
ATC650	ATC-650 series, 33 to 650°C (91 to 1202°F)
Model version	
A	Basic model no sensor-under-test or reference sensor input
B	Including sensor-under-test and reference sensor input
Power supply (US deliveries 60 Hz only)	
115	115VAC
230	230VAC
Mains power cable type	
A	European, 230V,
B	USA/CANADA, 115V
C	UK, 240V
D	South Africa, 220V
E	Italy, 220V
F	Australia, 240V
G	Denmark, 230V
H	Switzerland, 220V
I	Israel, 230V
Insert type and size	
XXX	1 x Insert for dry-block configuration (see the previous insert pages for the right insert codes)
Calibration certificate	
F	NPL Traceable temperature certificate (standard for Europe, Asia, Australia and Africa)
G	NIST traceable temperature certificate (standard for Americas)
H	Accredited certificate
Options	
A	Basic calibration kit
C	Carrying case
R	90° angled reference sensor with accredited certificate (STS100A901AH)
X	No option used

ATC156B230AM01FX Sample order number
 JOFRA ATC-156 B with standard accessories, 230VAC, European power cord, dry-block configuration with multihole insert type M01, and NPL traceable temperature certificate.



AMETEK Calibration Instruments is one of the world's leading manufacturers and developers of calibration instruments for temperature, pressure and process signals as well as for temperature sensors both from a commercial and a technological point of view.

JOFRA Temperature Instruments
 Portable precision thermometers. Dry-block and liquid bath calibrators: 4 series, with more than 25 models and temperature ranges from -90° to 1205°C / -130° to 2200°F. All featuring speed, portability, accuracy and advanced documenting functions with JOFRACAL calibration software.

JOFRA Pressure Instruments
 Convenient electronic systems ranging from -1 to 1000 bar (25 inHg to 14,500 psi) - multiple choices of pressure ranges, pumps and accuracies, fully temperature-compensated for problem-free and accurate field use.

JOFRA Signal Instruments
 Process signal measurement and simulation for easy control loop calibration and measurement tasks - from handheld field instruments to laboratory reference level bench top instruments.

JOFRA / JF Marine Instruments
 A complete range of calibration equipment for temperature, pressure and signal, approved for marine use.

FP Temperature Sensors
 A complete range of temperature sensors for industrial and marine use.

M&G Pressure Testers
 Pneumatic floating-ball or hydraulic piston dead weight testers with accuracies to 0.015% of reading.

M&G Pumps
 Pressure generators from small pneumatic "bicycle" style pumps to hydraulic pumps generating up to 1,000 bar (15,000 psi).

*...because calibration is
 a matter of confidence*

AMETEK®
 CALIBRATION INSTRUMENTS

[Visit us at www.TestEquipmentDepot.com](http://www.TestEquipmentDepot.com)

[Back to the Ametek ATC-157A Product info](#)