

RH10UC SD To HD Upconverter R-series Card Module

User Manual

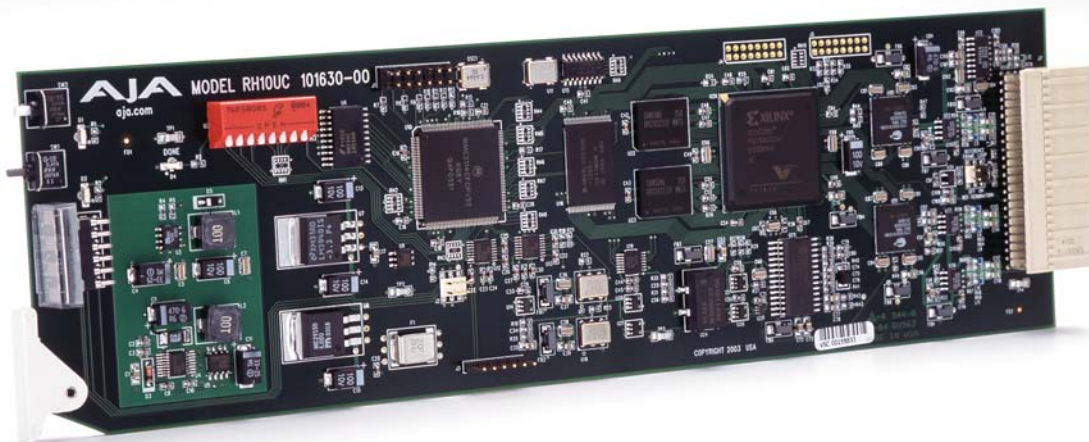

AJA
AJA VIDEO SYSTEMS INC

Revised April 5, 2006
Software Version 2.3

Trademarks

AJA, Io, and Kona are trademarks of AJA Video, Inc. All other trademarks are the property of their respective holders.

Notice

Copyright © 2006 AJA Video, Inc. All rights reserved. All information in this manual is subject to change without notice. No part of the document may be reproduced or transmitted in any form, or by any means, electronic or mechanical, including photocopying or recording, without the express written permission of AJA Inc.

FCC Emission Information

This equipment has been tested and found to comply with the limits for a Class A digital device, pursuant to Part 15 of the FCC Rules. These limits are designed to provide reasonable protection against harmful interference when the equipment is operated in a commercial environment. This equipment generates, uses and can radiate radio frequency energy and, if not installed and used in accordance with the instruction manual, may cause harmful interference to radio communications. Operation of this equipment in a residential area is likely to cause harmful interference in which case the user will be required to correct the interference at his own expense. Changes or modifications not expressly approved by AJA Video can effect emission compliance and could void the user's authority to operate this equipment.

Limited Warranty

AJA Video warrants that this product will be free from defects in materials and workmanship for a period of five years from the date of purchase. If a product proves to be defective during this warranty period, AJA Video, at its option, will either repair the defective product without charge for parts and labor, or will provide a replacement in exchange for the defective product.

In order to obtain service under this warranty, you the Customer, must notify AJA Video of the defect before the expiration of the warranty period and make suitable arrangements for the performance of service. The Customer shall be responsible for packaging and shipping the defective product to a designated service center nominated by AJA Video, with shipping charges prepaid. AJA Video shall pay for the return of the product to the Customer if the shipment is to a location within the country in which the AJA Video service center is located. Customer shall be responsible for paying all shipping charges, insurance, duties, taxes, and any other charges for products returned to any other locations.

This warranty shall not apply to any defect, failure or damage caused by improper use or improper or inadequate maintenance and care. AJA Video shall not be obligated to furnish service under this warranty a) to repair damage resulting from attempts by personnel other than AJA Video representatives to install, repair or service the product, b) to repair damage resulting from improper use or connection to incompatible equipment, c) to repair any damage or malfunction caused by the use of non-AJA Video parts or supplies, or d) to service a product that has been modified or integrated with other products when the effect of such a modification or integration increases the time or difficulty of servicing the product.

THIS WARRANTY IS GIVEN BY AJA VIDEO IN LIEU OF ANY OTHER WARRANTIES, EXPRESS OR IMPLIED. AJA VIDEO AND ITS VENDORS DISCLAIM ANY IMPLIED WARRANTIES OF MERCHANTABILITY OR FITNESS FOR A PARTICULAR PURPOSE. AJA VIDEO'S RESPONSIBILITY TO REPAIR OR REPLACE DEFECTIVE PRODUCTS IS THE WHOLE AND EXCLUSIVE REMEDY PROVIDED TO THE CUSTOMER FOR ANY INDIRECT, SPECIAL, INCIDENTAL OR CONSEQUENTIAL DAMAGES IRRESPECTIVE OF WHETHER AJA VIDEO OR THE VENDOR HAS ADVANCE NOTICE OF THE POSSIBILITY OF SUCH DAMAGES.

Features

- Full 10-bit broadcast quality SD to HD upconverter mode of operation
- HD Framesync mode of operation
- 8/10 bit SMPTE 259 SDI input, 2 re-clocked outputs
- 8/10 bit SMPTE 292 HD-SDI output, 4 outputs
- 8 Channels of Embedded SDI Audio are supported in Upconvert mode (audio is not supported in HD Framesync mode)
- bi/tri-level sync genlock input, 2 BNC loop-through with adjustable output timing
- 4:3 or 16:9 SD inputs
- 4:3 to 16:9 conversion modes:
 - 4:3 pillar box (4:3 image in center of screen, black sidebars)
 - 14:9 pillar box (4:3 image zoomed slightly to fill a 14:9 image, black sidebars)
 - Full Screen (for anamorphic inputs)
 - Letterbox (input 16:9 letterbox is zoomed to full screen)
 - Widezoom (a combination of zoom and horizontal stretch to fill 16:9 screen; will introduce a small aspect ratio error)
- Separate multipoint H and V filters
- Motion adaptive interpolation
- 16 bit coefficients, 16 bit internal data paths
- Accurate 16 bit SD to HD colorspace conversion
- 1 slot AJA FR1 or FR2 frame

Upconverter Specifications

Item	Specification
Input	SDI (525 or 625) in Upconvert Mode HD SDI (1080i or 720p) in HD Framesync Mode
Output	HD SDI (1080i or 720p)
Delay	1 Frame. Audio is delayed to compensate for the delay through the video path.
Power	7 Watts

I/O Connections

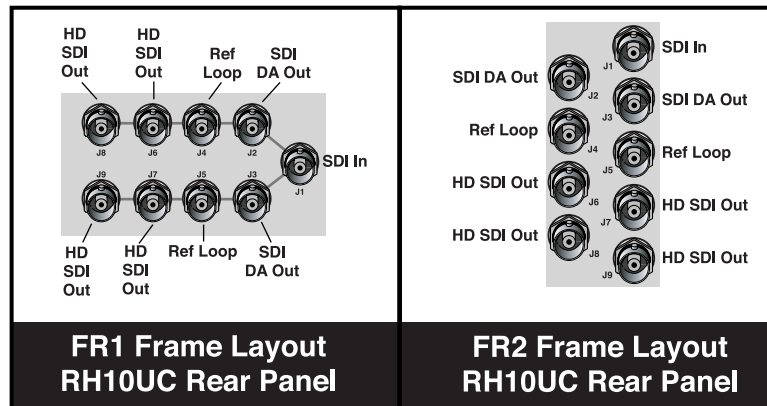

FR1 and FR2 BNC Connector Assignments, RH10UC Card Module

When the RH10UC module is installed in an AJA FR1 or FR2 frame, a corresponding group of 9 BNCs on the rear panel then provide I/O for the module. The illustration above shows the connector assignments for both the FR1 and FR2 when used with the RH10UC.

User Controls

The user interface for the RH10UC consists of two toggle switches and a 4-character alphanumeric display. See the photo “*RH10UC User Interface Controls*” that follows for control location and function.

The *Parameter Select* (PS) switch selects a parameter for adjustment and viewing on the display. Once a desired parameter is selected by moving the PS switch, you then use the other switch—called *Parameter Adjust* (PA)—to make a change to the parameter setting. Both switches are toggle switches that can be pushed to the right or left, allowing you to move forward or backward through available choices. After actuation, either switch will return to a middle position.

If you move a switch and hold it in place (left or right), the RH10UC will sense this and auto-increment or decrement.

By default, the 4-character display shows the current status of the RH10UC—referred to as status mode. When you’re adjusting parameters or settings, the display changes from status mode to adjust mode to show the new value settings or parameters. After a period of inactivity the display always reverts to status mode.

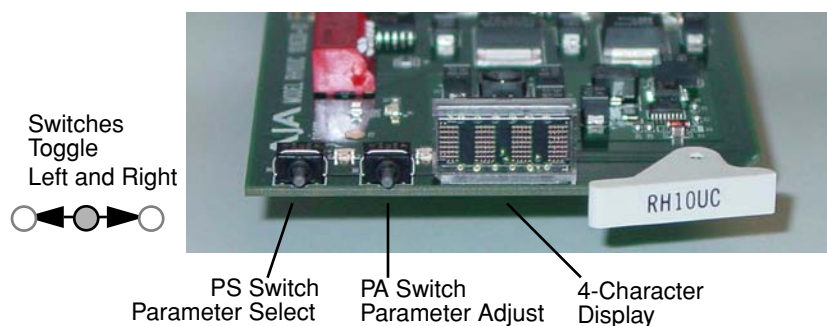

RH10UC User Interface Controls

Normal Operation Status Mode

The RH10UC display by default will show you which inputs are present, any detected error conditions, and the functional mode the board is in (upconverting, downconverting, HD/SD framesync, etc.). After the board is powered on, it enters *status mode* and stays there until a toggle switch is selected and you enter *adjust mode*. After 5 seconds of inactivity in adjust mode, it then returns to status mode.

While in status mode, the 4-character display indicates the following:

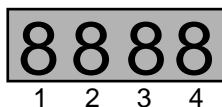

Character #	Indicates
1	S—Standard Definition (SD) input signal present E—Error on input signal H—High definition signal present (HD Framesync mode only)
2	Blank—not used
3 or 4	Mode Mnemonic: these codes show what the board is doing UP—up convert HF—High Definition Framesync

Editing and Viewing Board Settings Adjust Mode

Moving the PS switch in either direction causes the RH10UC to enter *adjust mode*. When this happens, the display will change to indicate the parameter being shown/edited.

Character #	Indicates
1	Normally displays parameter number 0 through 9, and A to Z (some numbers and letters are currently not used—only those used will be discussed in this document). If the parameter value (see below) exceeds 3-digits, this display character will also be used so 4-digits of the value can be viewed.
1 to 4	A 1 to 4-character code that indicates a parameter value. Usually the value will be shown in characters 2 through 4, except when the value requires all 4 characters.

When a parameter is shown in adjust mode, the last selected parameter is shown in character 1 and the current parameter value is shown in characters 2 through 4—if the value exceeds 3 digits, then all 4 characters in the display are used to show the value. Parameter choices and their definitions are listed in a table on the following page.

Selecting Parameters

Move the PS switch to the left to increment the parameter number or move it to the right to decrement the parameter number. Characters 2 through 4 will change to reflect the settings of these parameters as they are incremented/decremented.

Editing Parameters

When a parameter has been selected with the PS switch, use the PA switch to then change the parameter value (as displayed by characters 2 through 4) to another value. Like the PS switch, you'll move PA switch to the left or right to scroll through the setting choices. When a desired choice is found, simply leave it at that choice to select it.

Changing Operating Modes

Changing the selection in Param 0 from “UP” to “HF” selects the operating mode of the board and results in alternate sets of parameters and definitions. The two tables that follow show the parameter choices and definitions available when the board is in Upconvert or HD Framesync mode. Making a change in Param 0 results in an alternate bitfile to be loaded and the HD Framesync H and V output timing params to be loaded into the registers. During the bitfile loading process you may notice a short delay when the switches are not responsive. After the process completes, the unit will return to the status display.

In the Status display, which is active when the unit's switches have not been toggled for 5 seconds or more, an “H” will appear in the character 1 position if the unit is in HD Framesync mode—and there is a valid HD signal present on both the video input and the genlock input (the two must match).

Parameter Choices and Definitions When in Upconvert Mode

Parameter (Character 1)	Definitions (Choices are shown in italics)
0	Selects a Mode of operation for the board. Choices are: UP—up convert HF—high definition framesync
1	Output Format. Choices are: li—1080i 59.94Hz 7p—720p 59.94Hz A—automatic; output follows the tri-sync input (default)
2	Upconvert Mode. Choices are: 43—4x3 pillar box format 14—14x9 pillar box format (default) FS—full-screen (anamorphic display) format LB—16x9 letterbox input to full WZ—wide zoom format
5	Output Timing Mode, Set Reference Source. Choices are: R—reference input I—video input F—free run (default)
6	ON—allows VITC timecode and Closed Caption (CC) information to be passed on lines 20 and 21. OFF—lines 20 and 21 are blanked (default).
7	Freeze Video ON—Freezes the output video. OFF—Not Frozen (default).
8	Generate test pattern: ON—75% color bars OFF—none (default)
9	ON—Sharp Vertical Filter. Results in sharper image, with increased edge artifacts. OFF—Standard Vertical Filter (default). Provides the best possible image, although edges are not as sharp.
A	Display SD Input Format, possible values are: A—No input detected AERR— Input error detected A525—SD 525 A625—SD 625

Parameter (Character 1)	Definitions (Choices are shown in <i>italics</i>)
H	<p>Output Timing Adjust—Horizontal</p> <p>The maximum range changes based on the output frame rate and the frame geometry. Switch adjusts value by pixels to shift horizontally.</p> <p>The factory defaults are zero-timed values as measured empirically at AJA. They are given in the table below.</p> <p>The RH10UC remembers H and stores it in flash, recalling it as needed when the output frame rate or geometry changes.</p> <p>Refer to the H and V Parameter Reference Table appearing later in this manual for value ranges.</p>
V	<p>Output Timing Adjust—Vertical</p> <p>The maximum range changes based on the output frame rate and the frame geometry. Switch adjusts value by lines in frame.</p> <p>V delays are signed numbers, with zero timing relative to the reference signal noted as zero (“0”). Zero is the factory default for both V timing parameters.</p> <p>The RH10UC remembers V and stores it in flash, recalling it as needed when the output frame rate or geometry changes.</p> <p>Refer to the H and V Parameter Reference Table that follows for ranges.</p>
I	Information—shows current software version
W	<p>Set RH10UC To Factory Defaults</p> <p>To set all values to factory defaults, select Param W, and move the adjust switch to the right. This will set all parameters in the system to factory values. After a 5 second inactivity time-out, the values will be written to flash.</p> <p>If all the values in the system match the factory defaults, either through adjustment or by setting them as above, the display for param W will be “WFAC”. If any of the values are different, the display for param W will simply be “W”.</p>

Parameter Choices and Definitions When in HD Framesync mode

Parameter (Character 1)	Definitions (Choices are shown in <i>italics</i>)
0	Selects a Mode of operation for the board. Choices are: UP—up convert HF—high definition framesync
5	Output Timing Mode, Set Reference Source. Choices are: R—reference input I—video input F—free run (default)
7	Freeze Video ON—Freezes the output video. OFF—Not Frozen (default).
A	Display HD Input Format, possible values are: A—No input detected AERR— Input error detected A1p2—HD1080psf 23.98 A1i6—HD 1080i 59.94 or 1080i 60 A1i5—HD 1080i 50 A7p6—HD 720p 59.94 or 720p 60

Parameter (Character 1)	Definitions (Choices are shown in italics)
V	<p>Output Timing Adjust—Vertical</p> <p>The maximum range changes based on the output frame rate and the frame geometry. Switch adjusts value by lines in frame.</p> <p>V delays are signed numbers, with zero timing relative to the reference signal noted as zero (“0”). Zero is the factory default for both V timing parameters.</p> <p>The RH10UC remembers V and stores it in flash, recalling it as needed when the output frame rate or geometry changes.</p> <p>Refer to the H and V Parameter Reference Table that follows for ranges.</p>
H	<p>Output Timing Adjust—Horizontal</p> <p>The maximum range changes based on the output frame rate and the frame geometry. Switch adjusts value by pixels to shift horizontally.</p> <p>The factory defaults are zero-timed values as measured empirically at AJA. They are given in the table below.</p> <p>The RH10UC remembers H and stores it in flash, recalling it as needed when the output frame rate or geometry changes.</p> <p>Refer to the H and V Parameter Reference Table that follows for ranges.</p>
I	Information—shows current software version
W	<p>Set RH10UC To Factory Defaults</p> <p>To set all values to factory defaults, select Param W, and move the adjust switch to the right. This will set all parameters in the system to factory values. After a 5 second inactivity time-out, the values will be written to flash.</p> <p>If all the values in the system match the factory defaults, either through adjustment or by setting them as above, the display for param W will be “WFAC”. If any of the values are different, the display for param W will simply be “W”.</p>

H and V Parameter Reference Table For Upconvert Mode

Output Geometry @ FR	Min V Delay	Zero-timed V Delay	Max V Delay	Min H Delay	Zero-timed H Delay	Max H Delay
1080i @ 29.97 Hz	-999	0	562	0	1877	2199
1080i @ 25 Hz	-999	0	562	0	2014	2639
720p @ 59.94 Hz	-749	0	740	0	1304	1649
720p @ 50 Hz	-749	0	740	0	1304	1649

H and V Parameter Reference Table For HD Framesync Mode

Output Geometry @ FR	Min V Delay	Zero-timed V Delay	Max V Delay	Min H Delay	Zero-timed H Delay	Max H Delay
1080i @ 29.97 Hz	-999	0	5	0	2134	2199
1080i @ 25 Hz	-999	0	5	0	68	2639
1080psf @ 23.98 Hz	-999	0	5	0	2134	2749
720p @ 59.94 Hz	-749	0	5	0	0	1649
720p @ 50 Hz	-749	0	5	0	1100	1979

External Reference Information

The RH10UC expects the External Reference to be an HD Tri-level sync signal. The Reference must be consistent with the Output Format selection. If the Output Format selection is "A" for automatic - the RH10UC will detect the format of the Tri-level sync input and set the Output Format to the detected format. If no reference is provided, the RH10UC will lock to the input video.

The External Reference input can come from two different sources on the RH10UC. There are jumpers on the RH10UC (see figure below) for selecting the external reference source and for optionally terminating the selected reference source.

Looping Reference

The RH10UC cell group of 9 BNCs contains two BNCs that can be used for a looping reference connection. If this method is used, then the reference select setting on the RH10UC should be set to "LOOP" and the TERMINATION setting should be set to "OFF" (no termination). Optionally, if you're using only one of the looping reference BNCs, then the TERMINATION setting should be set to "ON."

Frame Reference

Alternatively, the RH10UC installed in a FR1 or FR2 frame can use the frame's frame reference input BNC connector, which feeds an external reference video signal to all modules installed in the frame. How the signal is distributed differs for the FR1 and FR2 frames. Additionally, individual modules can usually be strapped as to whether external reference is distributed from the frame or directly to BNCs on the module's corresponding cell group (the 9 BNCs on the rear panel).

FR1 Frame: the external reference signal is distributed passively to all frame modules. If you wish to use the frame reference, the RH10UC should have "FRAME" reference selected on the module strapping, and one and only one card in the frame should have "TERMINATION" set to "ON." All other cards in the frame should have TERMINATION set to "OFF."

FR2 Frame: the external reference signal is distributed by an in-frame distribution amplifier to all frame modules. This system terminates the Frame Reference input BNC and buffers the signal to all slots. If using frame reference, the RH10UC installed in the FR2 frame should have "FRAME" set for reference select, and all cards should have TERMINATION set to "OFF."

Front of Card

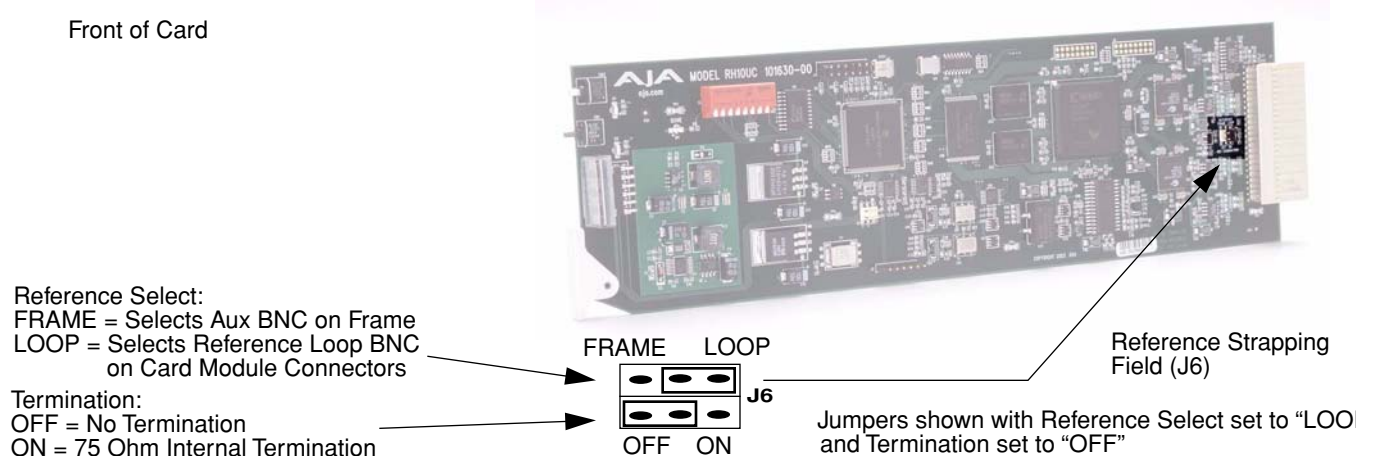

Reference Select and Termination Configuration

RH10UC Aspect Ratio Modes

4:3 Upconverts To

These displays on 16:9

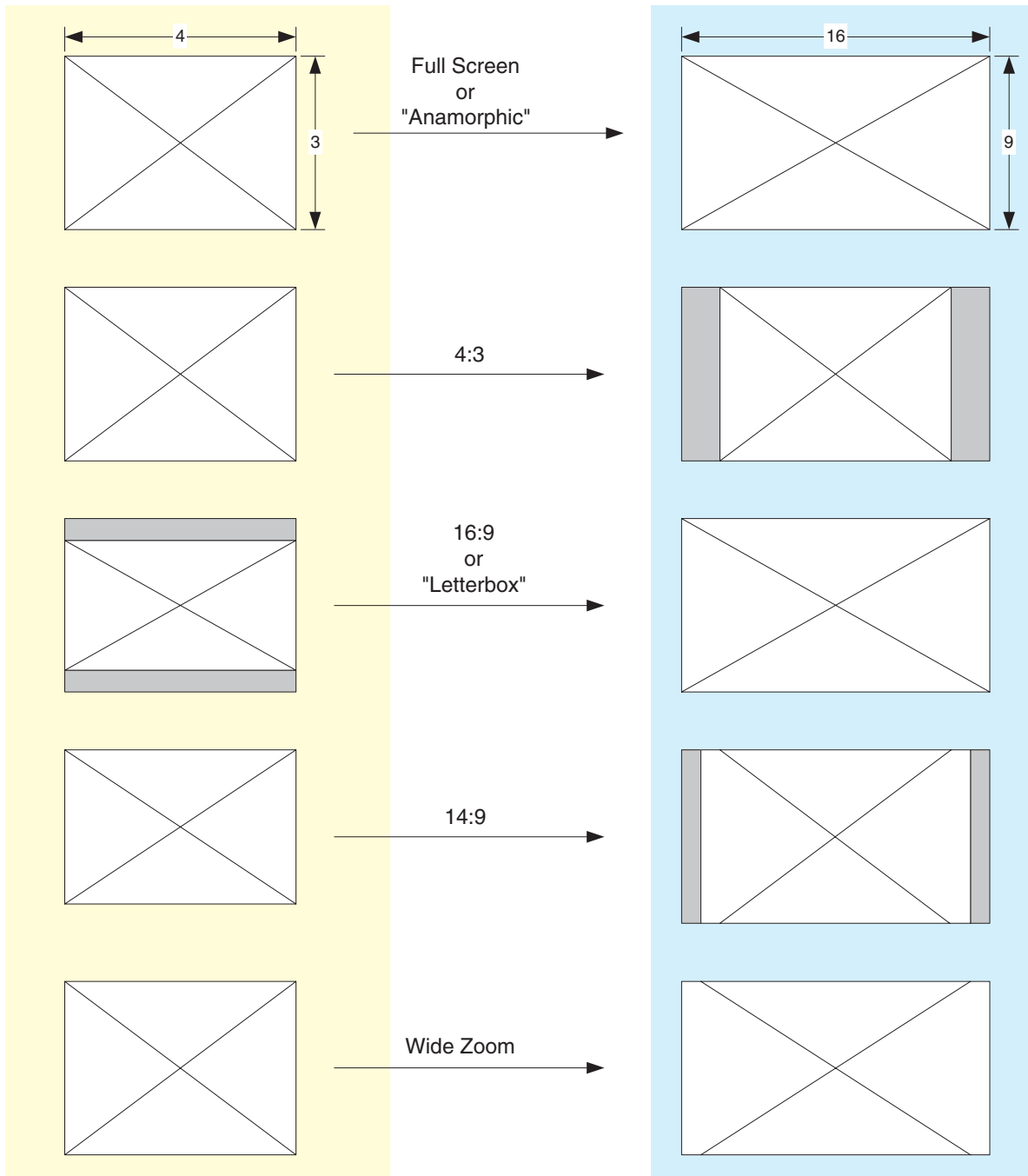

 Visit us at www.TestEquipmentDepot.com