

THE BEST SOLUTION FOR SD CAPTURE AND PLAYBACK—AJA QUALITY AT AN AFFORDABLE PRICE

AJA-quality standard definition video capture and playback isn't just for the big guys. The affordably priced KONA LS is the perfect engine for a professional Final Cut Pro 5 editing system. AJA has made a significant investment in the development of exceptional KONA hardware, making KONA cards the preferred choice for performance and stability in the broadcast industry. Now, with KONA LS, everyone can enjoy the features, rock-solid video/audio, and factory support that exemplify AJA products.

KONA LS does away with the need to spend serious money on a nonlinear editing suite. This affordable card, when configured with a PCIe Apple Power Mac™ G5, RAID storage, computer display, and video monitor—along with Final Cut Pro 5—achieves the same editing quality as an expensive turnkey suite.

The KONA LS supports 10-bit resolution SMPTE SDI, using a QuickTime compatible format. KONA LS also has great audio I/O support: balanced analog, AES, and embedded SDI audio. KONA LS includes—hardware sample-rate conversion on AES inputs—eliminating source synchronizing requirements. And the optional KL-Box for KONA LS provides all the standard features of the cable in an easy-to-use rackmount panel.

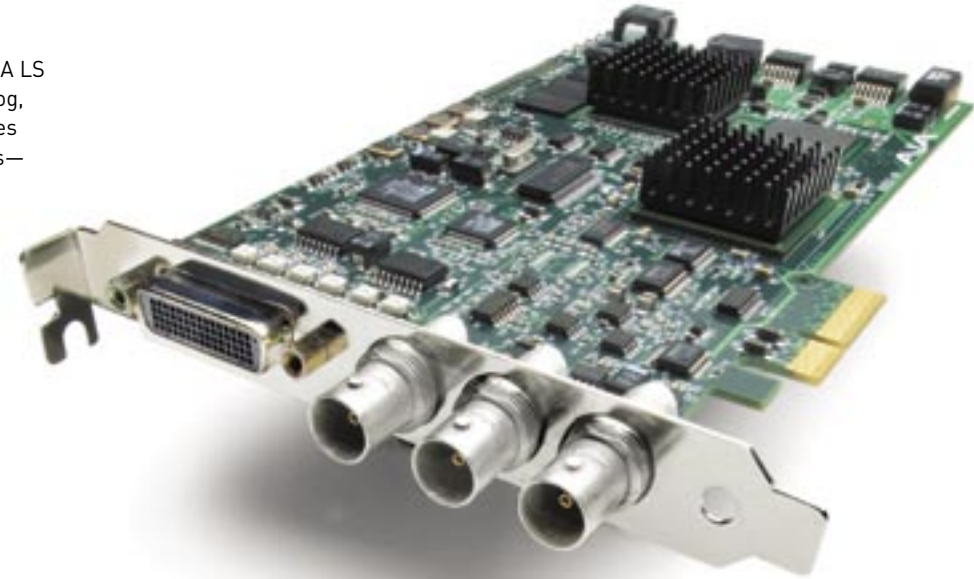

KONA LSe Shown



KONA LSe Breakout Cables (Supplied)

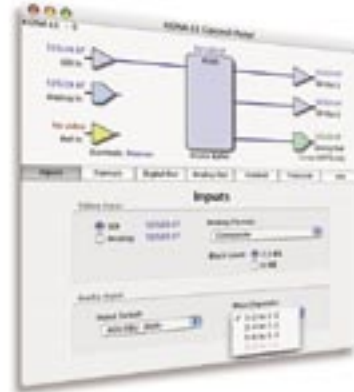

KL-Box for KONA LSe & LS (Optional)

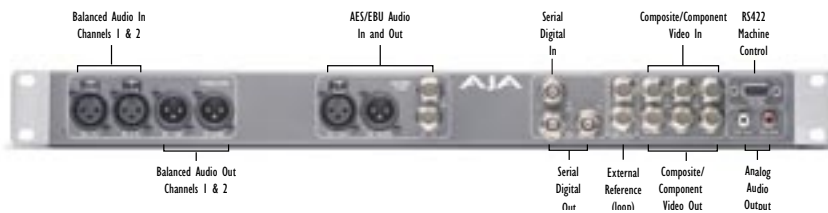

KONA LS FEATURES

- 12-bit Component/Composite/S-video analog I/O
- SDI input, 2 independent SDI outputs
- AES I/O; sample rate conversion on input (2 channel, XLR)
- Balanced analog audio I/O (2 channel, XLR)
- 8-channel SDI embedded audio support
- Broadcast-quality TBC with VHS support
- Genlock and RS-422 machine control
- AJA QuickTime™ drivers
- Apple Final Cut Pro™ support
- After Effects, Combustion, Motion, and more
- Supports all popular standard definition formats: 8/10-bit uncompressed, JPEG, DV25/50, and 3:2 pulldown for 24Hz support
- Cables standard, KL-Box breakout optional
- 3-year warranty
- Available in PCIe as KONA LSe
- Available in PCI compatible as KONA LS

KONA LSe Standard Breakout Cable

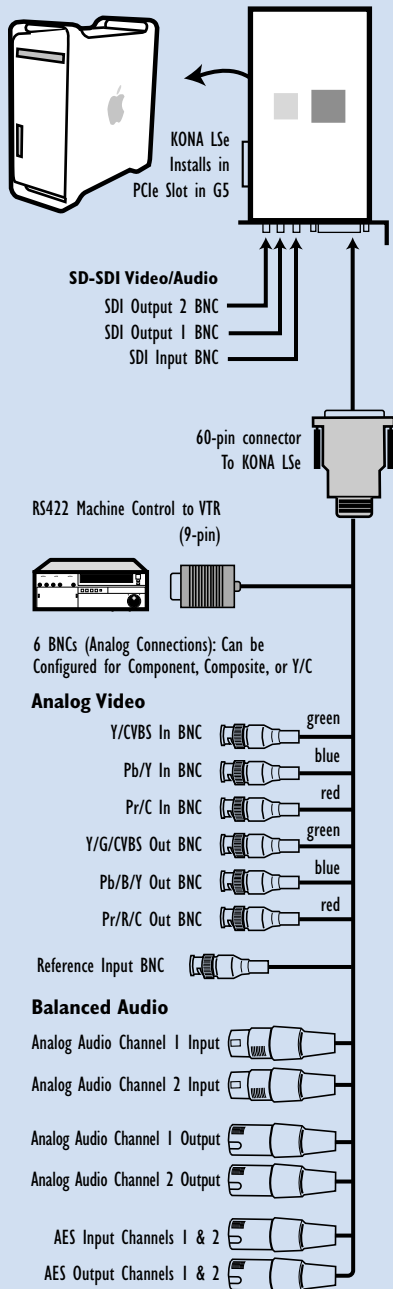

KONA LS Standard Breakout Cable

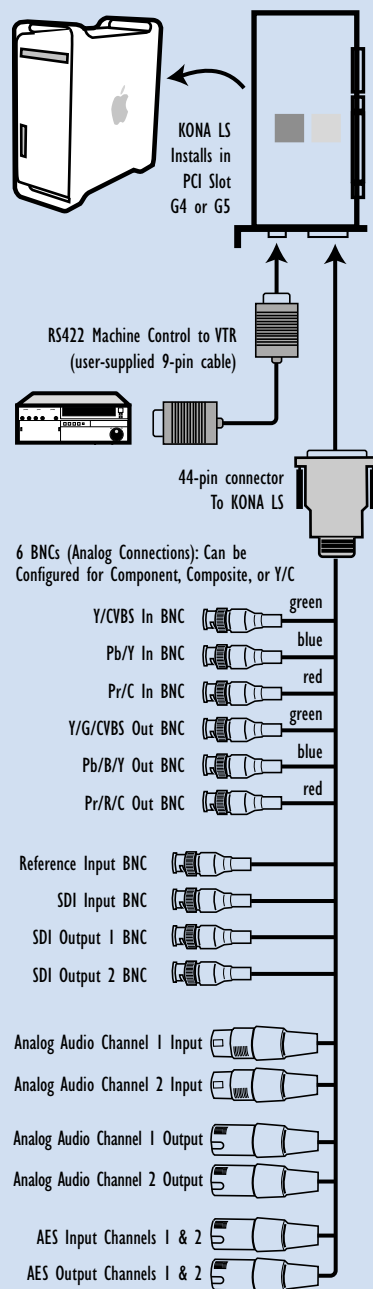

KONA^{LSe}

KONA LSe and LS SPECIFICATIONS

KONA LS

PCI compatible

KONA LSe

PCIe compatible

Video Input

Digital: 8 or 10-bit SDI, SMPTE-259

Analog:

Composite/S-Video (Y/C): NTSC, NTSCJ, PAL
12-bit A/D, 2x oversampling
5 line adaptive comb filter decoding
Component: SMPTE/EBU N10, Betacam 525 line, Betacam 525J, RGB
12-bit A/D, 2x oversampling

Video Output

Digital: 8 or 10-bit SDI, SMPTE-259

Analog:

Composite/S Video: NTSC, NTSCJ, PAL
12-bit D/A, 8x oversampling
Component: SMPTE/EBU N10, Betacam 525 line, Betacam 525J, RGB
12-bit D/A, 8x oversampling

Audio Input

Digital:

2-channel 24-bit AES/EBU, 48kHz sample rate
Synchronous or Non-synchronous (Internal sample rate conversion)
24-bit SMPTE-259 SDI embedded audio, 8-ch, 48kHz synchronous

Analog:

2-channel balanced input
+24dbu Full Scale Digital
24-bit A/D, 48kHz sample rate
+/- 0.2db 20 to 20kHz Frequency Response

Audio Output

Digital:

2-channel 24-bit AES/EBU, 48kHz sample rate
24-bit SMPTE-259 SDI embedded audio, 8-ch, 48kHz synchronous

Analog:

2-channel balanced output (XLR)
+24dbu Full Scale Digital (0dbFS)
24-bit D/A, 48kHz sample rate
+/- 0.2db 20 to 20kHz Frequency Response
2-channel unbalanced output (RCA-jack):
requires KL-Box option

Reference Input

Analog Color Black
1 BNC on standard breakout cable (75 ohm terminating)
KL-Box (optional): 2 BNCs, passive loop

Machine Control

RS-422, Sony 9-pin protocol Connector provided on KONA LS breakout cable and on optional KL-Box.

Incredible 3-Year Warranty

AJA Video warrants that KONA products will be free from defects in materials and workmanship for a period of three years from the date of purchase.

About AJA Video Systems, Inc.

Since 1993, AJA Video has been a leading manufacturer of video interface and conversion solutions, bringing high-quality, cost-effective digital video products to the professional broadcast and post-production markets. AJA offers lo (the "ultimate" capture box), KONA and XENA PCI capture cards, miniature stand-alone converters, and a complete line of rack mount interface and conversion cards and frames.

With headquarters and design center located in Grass Valley, California, AJA Video offers its products through an extensive sales channel of dealers and systems integrators around the world. For further information, please see our website at www.aja.com

AJA Video Systems Inc.
P.O. Box 1033 • Grass Valley, California 95945
800.251.4224 • 530.274.2048 • www.aja.com

AS PASSIONATE AS YOU ARE

AJA
VIDEO SYSTEMS