

THE ONLY CARD FOR OS X AND FINAL CUT PRO 5 THAT PROVIDES BOTH HD AND SD ANALOG AND DIGITAL I/O

Not an entry-level card, KONA LHe offers a full ride to HD with no-compromise 10-bit uncompressed video, 2-channel AES and 8-channel embedded audio, analog composite/component video I/O, 2-channel analog audio I/O, broadcast-quality hardware down-conversion and TBC on analog inputs. KONA LHe bridges the analog and digital worlds by offering I/O for both. A lot of card for a low price, KONA LHe also features dual-monitor desktop viewing for editing ease. The KONA LHe comes standard with a breakout cable and also works with the optional KL-Box for rackmounted I/O convenience.

Supporting native 10-bit resolution, KONA LHe provides optimum quality for SD and HD—the maximum allowed in SMPTE SDI standards. Using the QuickTime format, KONA LHe captures directly to 10-bit files on disk, and also supports many legacy 8-bit formats for backward compatibility. KONA LHe also supports DVCPROHD and HDV, DV25, DV50, JPEG, and more.

In addition to perfection in video, KONA LHe offers all the audio support you'd ever want: native OS X multi-channel audio and 24-bit AES/EBU digital audio at 48kHz for digital production. For ease of use, KONA LHe also includes hardware sample-rate conversion on AES inputs—eliminating source synchronizing requirements.

As the only card available supporting HD/SD analog I/O, KONA LHe is perfect for not only uncompressed, but also HDV and other diverse workflows.

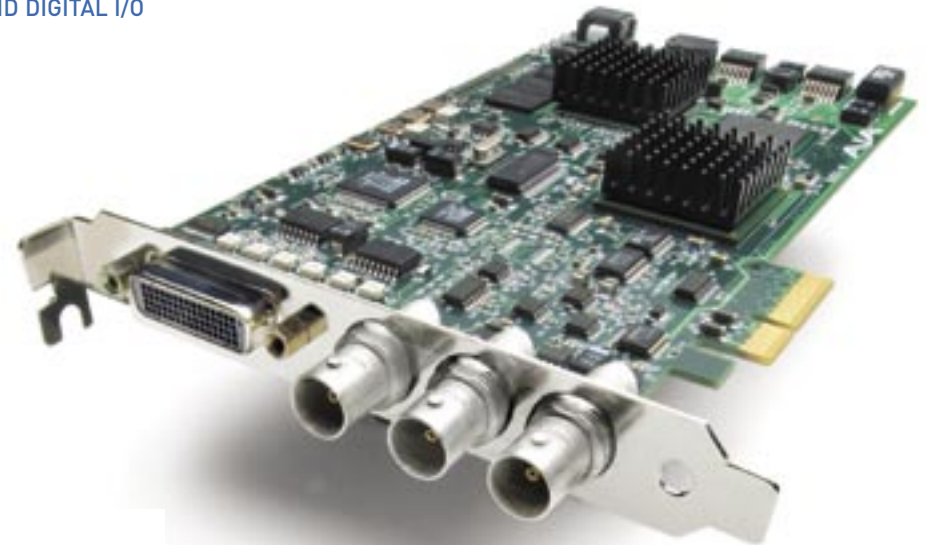

KONA LHe Shown

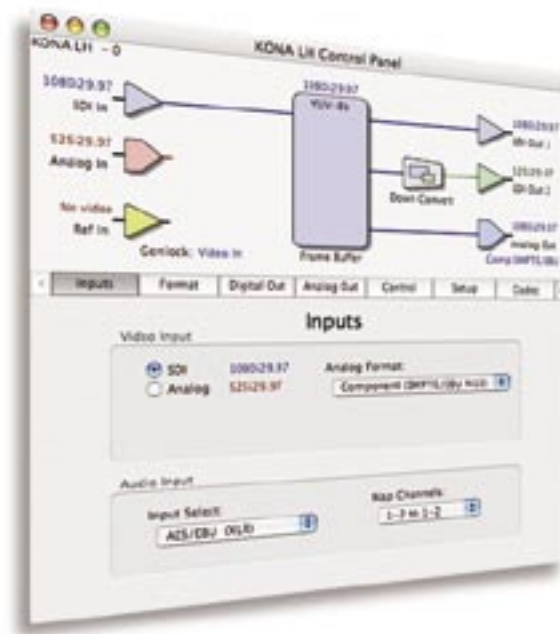

KONA Control Panel

KONA LH FEATURES:

- 10-bit Uncompressed SD/HD QuickTime Capture Card
- 12-bit HD analog component I/O
- 12-bit SD analog component or composite S-Video I/O
- 10-bit Hardware HD to SD down-conversion
- DVCPROHD hardware acceleration
- HDV hardware acceleration
- Dynamic RT Extreme hardware acceleration
- SDI or HD-SDI input
- 2 independent SDI/HD-SDI outputs
- 2-ch balanced XLR AES and 2-ch balanced XLR analog audio I/O
- 8-ch SDI embedded audio I/O
- HD/SD Genlock and RS-422 machine control
- Final Cut Pro 5, Motion, After Effects, Combustion, and more
- Cables standard, KL-Box breakout optional
- 3-year warranty
- Available in PCIe as KONA LHe
- Available in PCI/PCI-X compatible as KONA LH

KONA LHe HARDWARE ACCELERATION

Final Cut Pro users will love DVCPROHD, HDV, and Apple RT Extreme hardware acceleration, developed in close cooperation with Apple and available exclusively on KONA LHe. KONA LHe hardware takes a portion of the codec processing load off the CPU, allowing more RealTime (RT) effects in Final Cut Pro 5 when outputting. KONA LHe also has hardware support when capturing. This brings amazing RealTime HD production power to the desktop. With KONA LHe, any source can be captured using the DVCPROHD codec—giving you online HD quality at remarkably low data rates, allowing the internal PowerMac SATA storage to be used for HD capture, playback and RT effects. Of course, you'll obtain still better performance and more RT when using a fast SCSI or Fibre array, but this feature allows

HD to be used where only SD would have been considered due to budget or time constraints. KONA LHe even supports the DVCPROHD and HDV codecs with down-conversion—allowing projects to be down-converted to SD, or even up-converted for DVCPROHD capture.

HOW DOES KONA LHe ACCELERATE DVCPROHD, HDV, AND APPLE'S DYNAMIC RT?

Because KONA's precision hardware does part of the work, the G5 has more time available to process RT effects. This means more RT-effects power, and more RT streams.

Most broadcast codecs, including DVCPROHD and HDV, use a two-step process. The video is first scaled to a lower horizontal pixel count, and then the video is compressed. This is done because the slightly scaled video results in a

favorable trade-off between resolution and codec efficiency. KONA LHe's hardware not only dramatically speeds up the scaling part of the job, but it's also done with full 10-bit broadcast quality.

When using the Final Cut Pro 5 HDV codec, KONA LHe's hardware acceleration allows instantaneous RT playback for both monitoring and recording. Even KONA's down-converter works in realtime with HDV, allowing SD monitoring, dubs or mastering. This KONA LHe functionality makes HDV a fully professional solution.

The Panasonic DVCPROHD format takes advantage of KONA hardware as well. KONA's precision hardware allows capture and playback of HD-SDI video to and from the DVCPROHD codec at a quality level virtually

indistinguishable from native FireWire, while freeing up valuable RT processing power.

For Final Cut Pro 5's Dynamic RT feature, KONA's hardware is used to offload the video scaling as the "Playback Video Quality" dynamically adjusts. This allows more playback power—and because KONA handles it seamlessly, the Dynamic RT you see on the Mac monitor is the same as that shown on your professional broadcast monitor.

KONA LHe SUPPORTS FINAL CUT MULTI-CAM FEATURE

Final Cut Pro 5 now provides multi-cam playout—and KONA LHe supports it! With KONA hardware and a sufficient storage solution, you can handle up to 16 sources in realtime. Each stream of video is captured individually and then ganged together in Final Cut Pro 5 for a multi-cam editing workflow. The KONA LHe hardware seamlessly plays the multi-cam clips out

to professional broadcast monitors or decks, via SDI, HD-SDI or component video. Up to 16 sources can be viewed in realtime via the KONA (4-up, 6-up, 9-up, 16-up, etc.), or each individual source can be viewed as it is selected via Final Cut Pro 5.



KONA LHe Breakout Cables (Supplied)



KL-Box for KONA LHe & LH (Optional)

KONA^{LHe}

KONA LHe/LH Standard Breakout Cable

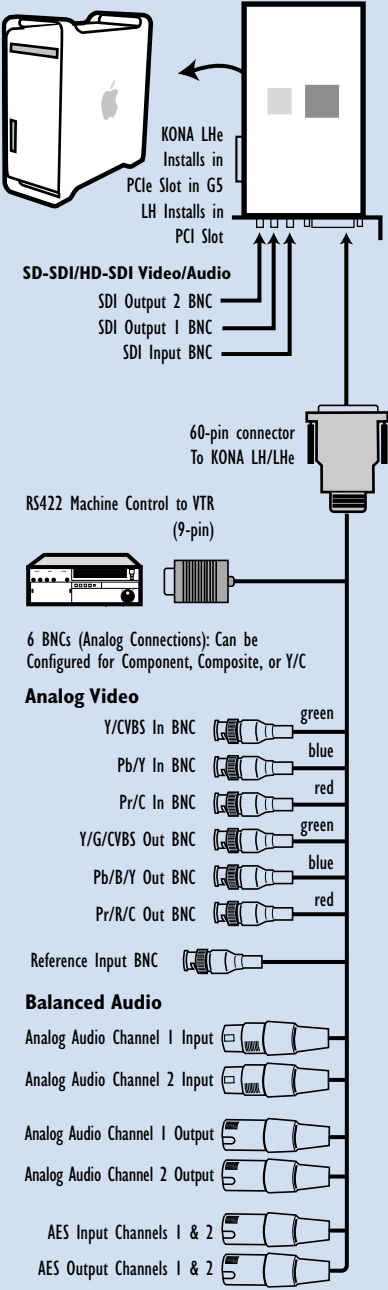

KONA LH SPECIFICATIONS

Formats

- 525i 29.97
- 625i 25
- 720p 59.94
- 720p 60
- 1080i 25
- 1080i 29.97
- 1080i 50
- 1080psf 23.98
- 1080psf 24

Video Input

Digital: 8 or 10-bit HD-SDI/SDI, SMPTE-259/292/296

Analog:

- Composite/S-Video (Y/C): NTSC, NTSCJ, PAL
- 12-bit A/D, 2x oversampling
- 3 line adaptive comb filter decoding
- SD Component: SMPTE/EBU N10, Betacam 525 line, Betacam 525J, RGB
- 12-bit A/D, 2x oversampling
- HD Component: YPbPr
- 12-bit A/D

Video Output

Digital: SD-SDI, SMPTE, 259M, 10-bits, BNC
HD-SDI SMPTE, 292/296, 10-bits, BNC

Analog:

- Composite/S Video: NTSC, NTSCJ, PAL
- 12-bit D/A, 8x oversampling
- SD Component: SMPTE/EBU N10, Betacam 525 line, Betacam 525J, RGB
- 12-bit D/A, 8x oversampling
- HD Component: YPbPr, RGB
- 12-bit D/A, 2x oversampling

Audio Input

Digital: 2-channel 24-bit AES/EBU, 48kHz sample rate

Synchronous or Non-synchronous (Internal sample rate conversion)

24-bit SMPTE-259 SDI embedded audio, 8 channel, 48kHz synchronous

Analog:

- 2-channel balanced input
- +24dbu Full Scale Digital
- 24-bit A/D, 48kHz sample rate
- +/- 0.2db 20 to 20kHz Frequency Response

Audio Output

Digital:

- 2-channel 24-bit AES/EBU, 48kHz sample rate
- 24-bit AES/EBU, 48kHz sample rate
- 24-bit SMPTE-259 SDI embedded audio, 8 channel, 48kHz synchronous

Analog:

- 2-channel balanced output
- +24dbu Full Scale Digital
- 24-bit D/A, 48kHz sample rate
- +/- 0.2db 20 to 20kHz Frequency Response

Down-Conversion

- Hardware 10-bit output, 24-bit internal processing
- Anamorphic: full-screen
- Letterbox: image is reduced with black top and bottom added to image area with the aspect ratio preserved
- Crop: image is cropped horizontally

Reference Input

- Analog Color or HD Tri-level
- 1 BNC on standard breakout cable (75 ohm terminating)
- KL-Box (optional): 2 BNCs, passive loop

Machine Control

- RS-422, Sony 9-pin protocol Connector provided on KONA LH breakout cable and on optional KL-Box.

Incredible 3 Year Warranty

AJA Video warrants that KONA products will be free from defects in materials and workmanship for a period of three years from the date of purchase.

About AJA Video Systems, Inc.

Since 1993, AJA Video has been a leading manufacturer of video interface and conversion solutions, bringing high-quality, cost-effective digital video products to the professional broadcast and post-production markets. AJA offers lo (the "ultimate" capture box), KONA and XENA PCI capture cards, miniature stand-alone converters, and a complete line of rack mount interface and conversion cards and frames.

With headquarters and design center located in Grass Valley, California, AJA Video offers its products through an extensive sales channel of dealers and systems integrators around the world. For further information, please see our website at www.aja.com

AJA Video Systems Inc.
P.O. Box 1033 • Grass Valley, California 95945
800.251.4224 • 530.274.2048 • www.aja.com

