

HD10AM HD/SD 8-Channel AES Embedder/Disembedder User Manual



AJA
AJA VIDEO SYSTEMS INC

June 29, 2006 P/N 101661-00

DESIGNED FOR
Dolby E

Dolby E
PARTNER

Introduction

The HD10AM is a dual rate 8 channel AES audio Embedder/Disembedder. The Disembedder is always functional, outputting group 1 and 2—or 3 and 4 (user selectable) when present on the input SDI. This is independent of the embedding process. The Embedder is user selectable, on a channel pair basis, to either “pass” SDI input audio or embed input AES audio from the breakout cable. The ability to pass incoming ancillary data makes it possible to embed up to 16 channels of audio by cascading two units: the first embedding to groups 1/2, and the second embedding to groups 3/4—or vice versa. It also means that any ancillary data packets in compliance with SMPTE 291M will be passed through as-is.

With the SRC dipswitch setting ON, AES inputs are sample rate converted to a 48KHz rate synchronous to the video input.

The HD10AM automatically detects and configures to the input video standard. The *Lock* LED glows red for HD and green for SD formats.

With the SRC dipswitch setting OFF, data packets are passed from the AES inputs to embedded ancillary packets un-altered. This is done according to SMPTE 337M. 48KHz synchronous ancillary packets are disembedded and passed unaltered to the AES outputs regardless of the position of the SRC dipswitch.

All AES3-2003 defined channel status bits are passed through unaltered in both the embed and dis-embed directions—except for the sample rate field, which is always set to 48KHz. The channel status CRC is re-calculated and inserted into the bitstream. This ability, along with a very small audio embed/disembed latency, ensures 100 percent compatibility with Dolby® bitstreams.

Features

- Dual rate HD-SDI/SDI Embedder/Disembedder
- 8 Channel AES I/O
- Supplied breakout cable for balanced AES - XLR connectors
- HD-SDI/SDI input
- 2 HD-SDI/SDI equalized outputs (following input)
- Dipswitch configuration
- 5-18VDC Power

Block Diagram

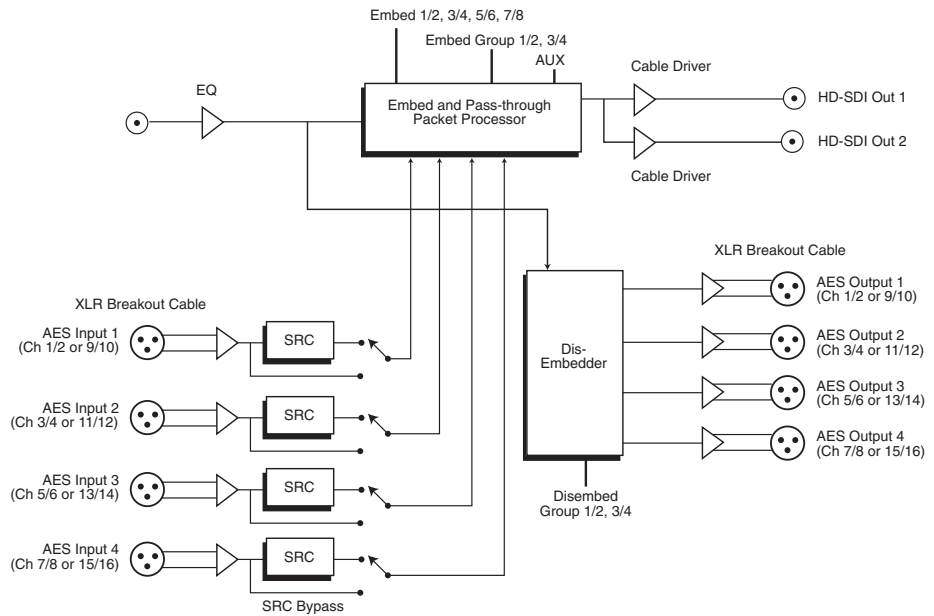

HD10AM, Block Diagram

I/O Connections

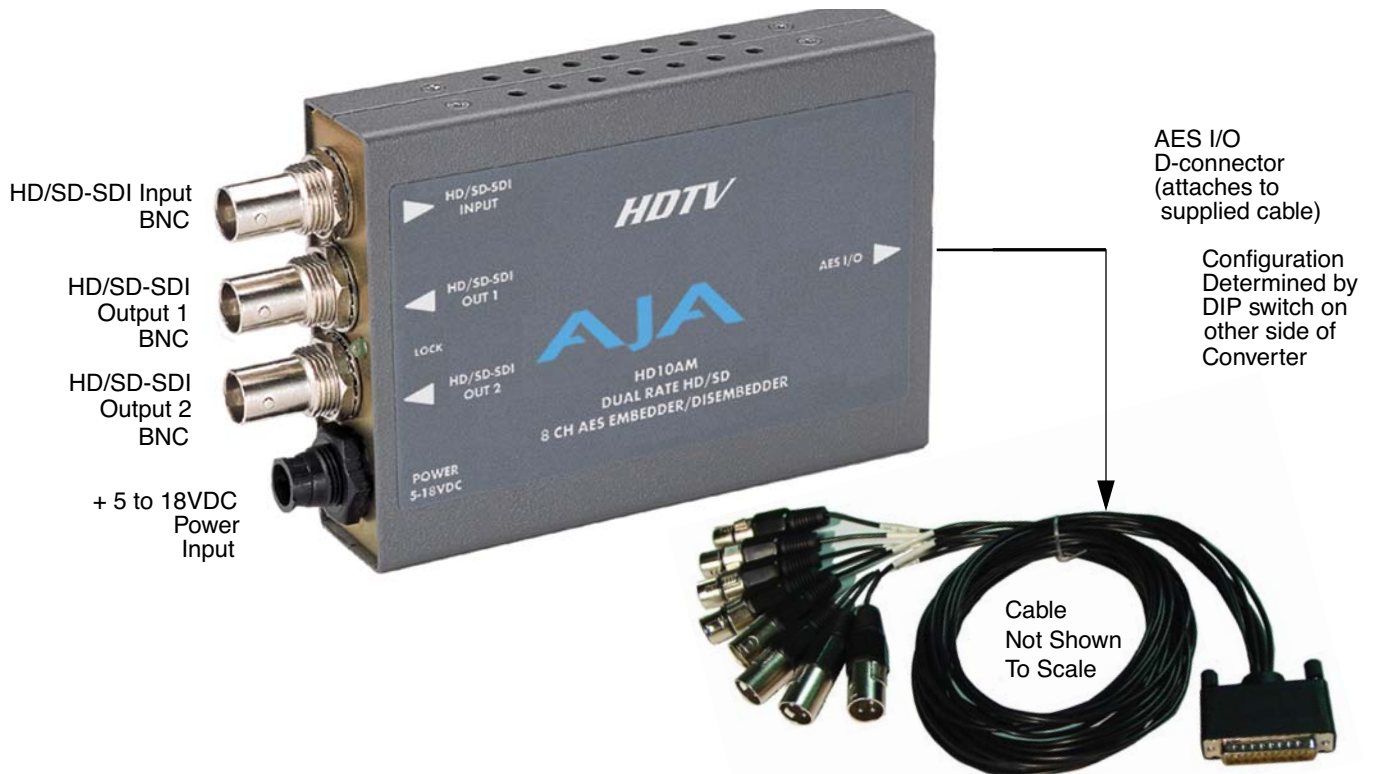

HD10AM and Cable, Side View

User Controls

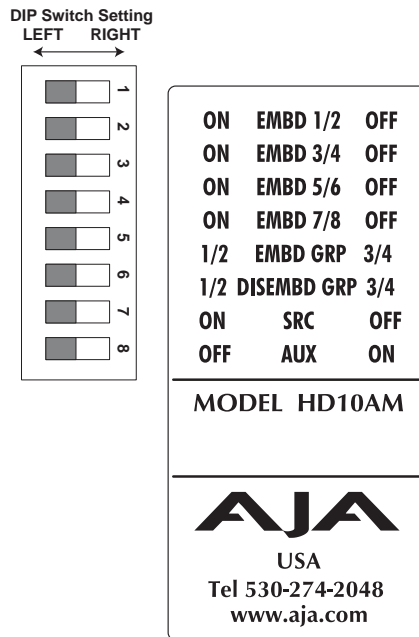

The user interface for the HD10AM is an 8-switch DIP accessible through a cut-out in the bottom of the unit. Use the DIP switches to configure how the AES embedding and disembedding functions.

Note: The combination of the AUX switch setting (switch 8) and the other switches determines the overall operation of the HD10AM.

The exact function of each DIP switch and what it controls is described on the following pages.

Factory default switch settings are all in the leftmost position.

Switch 1 (EMBD 1/2)—Controls audio embedding for channels 1/2

LEFT	RIGHT
Overwrite or embed new channel 1/2 packets	If AUX=LEFT: Pass any channel 1/2 packets on input SDI If AUX=RIGHT: Delete all channel 1/2 packets from input SDI

Switch 2 (EMBD 3/4)—Controls audio embedding for channels 3/4

LEFT	RIGHT
Overwrite or embed new channel 3/4 packets	If AUX=LEFT: Pass any channel 3/4 packets on input SDI If AUX=RIGHT: Delete all channel 3/4 packets from input SDI

Switch 3 (EMBD 5/6)—Controls audio embedding for channels 5/6

LEFT	RIGHT
Overwrite or embed new channel 5/6 packets	If AUX=LEFT: Pass any channel 5/6 packets on input SDI If AUX=RIGHT: Delete all channel 5/6 packets from input SDI

Switch 4 (EMBD 7/8)—Controls audio embedding for channels 7/8

LEFT	RIGHT
Overwrite or embed new channel 7/8 packets	If AUX=LEFT: Pass any channel 7/8 packets on input SDI If AUX=RIGHT: Delete all channel 7/8 packets from input SDI

Switch 5 (EMBD GRP)—Select AES channel mapping for embedded groups

LEFT	RIGHT
Embed to Groups 1 and 2 as specified in 272M and 299M (see following table)	Embed to Groups 3 and 4 as specified in 272M and 299M (see following table)

Switch 5 set LEFT, Embed to Groups 1 and 2, AES Channel Mapping:

AES Input Channel	SDI Embedded Group	Channel
1 →	1	1
2 →	1	2
3 →	1	3
4 →	1	4
5 →	2	5
6 →	2	6
7 →	2	7
8 →	2	8

Switch 5 set RIGHT, Embed to Groups 3 and 4, AES Channel Mapping:

AES Input Channel	SDI Embedded Group	Channel
1 →	3	9
2 →	3	10
3 →	3	11
4 →	3	12
5 →	4	13
6 →	4	14
7 →	4	15
8 →	4	16

Switch 6 (DISEMBD GRP)—Select AES channel mapping for disembedding groups

LEFT	RIGHT
Disembled from Groups 1 and 2 as specified in 272M and 299M (see following table)	Disembled from Groups 3 and 4 as specified in 272M and 299M (see following table)

Switch 6 set LEFT, disembled from Groups 1 and 2, AES Channel Mapping:

SDI Embedded Input Group	Channel	AES Output Channel
1	1 →	1
1	2 →	2
1	3 →	3
1	4 →	4
2	5 →	5
2	6 →	6
2	7 →	7
2	8 →	8

Switch 6 set RIGHT, disembled from Groups 3 and 4, AES Channel Mapping:

SDI Embedded Input Group	Channel	AES Output Channel
3	9 →	1
3	10 →	2
3	11 →	3
3	12 →	4
4	13 →	5
4	14 →	6
4	15 →	7
4	16 →	8

Switch 7 (SRC)—Control whether input AES audio is passed through the sample rate converters

LEFT	RIGHT
Pass all input AES audio through the sample rate converter before embedding (for example, PCM audio from a sync source)	Do not pass any input AES audio through the sample rate converter before embedding (for example, Dolby® Digital)

Note: Switch 7 affects all four inputs. For proper operation with the SRC bypassed, the AES input timing must be externally synchronized to the input SDI.

Switch 8 (AUX)—Control whether ancillary horizontal data is passed or deleted from input (used with switches 1 through 4)

LEFT	RIGHT
Whenever possible, pass all incoming ancillary data except packets marked for deletion	Delete all incoming horizontal ancillary data before embedding any new audio packets

Installation

Typically, HD10AM installation consists of the following:

1. disconnect +5VDC from the converter
2. configure the DIP switch for the desired equipment configuration
3. connect video equipment to the converter BNCs
4. apply +5VDC power to the converter (AJA power supply model DWP)

Specifications

Item	Specification
Video Formats	HD SMPTE 292/296/274M SD SMPTE 259M (Automatic Configuration)
Audio Data Formats	AES3-2003 SMPTE 337M
Video Input	HD-SDI or SDI BNC
Video Outputs (equalized)	HD-SDI or SDI BNC, 2 x BNC
Audio Inputs	4 x AES3 110 ohm XLR, Pro format
Audio Outputs	4 x AES3 110 ohm XLR, Pro format
Embedded Audio	SMPTE 272M (SD): 20-bit, 48KHz synchronous SMPTE 299M (HD): 24 bit, 48KHz synchronous
Video Processing Delay	HD Mode: 7 μ S SD Mode: 19 μ S
Audio Processing Delay	Disembed Delay: 290 μ S Embed Delay (SRC OFF): 290 μ S Embed Delay (SRC ON): 1500 μ S
Sample Rate Converter Resolution	24-bits
User Controls	External Dipswitch: Embedder on/off, Ch pairs 1/2 - 7/8 Input group select, 1/2, 3/4 Output Group Select, 1/2, 3/4 SRC Bypass AUX (pass or delete incoming ancillary data)
Size	5.8" x 3.1" x 1 (147 x 79 x 25mm)
Power	5-18V, 5 watts. Requires power supply.

