

# D5CE Serial Digital Encoder

## User Manual



**AJA**  
AJA VIDEO SYSTEMS INC

December 5, 2003 P/N 101635-00

## Introduction

The D5CE provides low cost, all digital conversion of SDI to either composite or component analog video. Three analog BNC outputs are user configurable to cover a wide range of format combinations including three composite, one composite and Y/C, YPbPr (SMPTE, EBU-N10), Betacam, or RGB. The D5CE is useful for monitoring video, level/phase checking, dubs, or desktop video applications. In addition, an equalized and re-clocked SDI loop-through output is provided. The D5CE automatically configures to 525 or 625 line component digital inputs and then outputs analog NTSC (525 line input), PAL (625 line input) or component as configured by the DIP switches.

The D5CE encodes the full dynamic range of input component video—values below black and above white are not clipped. In the NTSC mode, the 7.5 IRE pedestal can be disabled by the external DIP switch.

## Features

- Low Cost SDI to Component or Composite Analog
- User Selectable Component or Composite/YC Outputs
- YPbPr, Betacam, or RGB Component Formats
- Re-clocked Loop-Thru SDI Output
- Automatic NTSC/PAL Selection
- User Selectable Vertical/Horizontal Blanking
- External DIP switch user interface for configuration

## Block Diagram

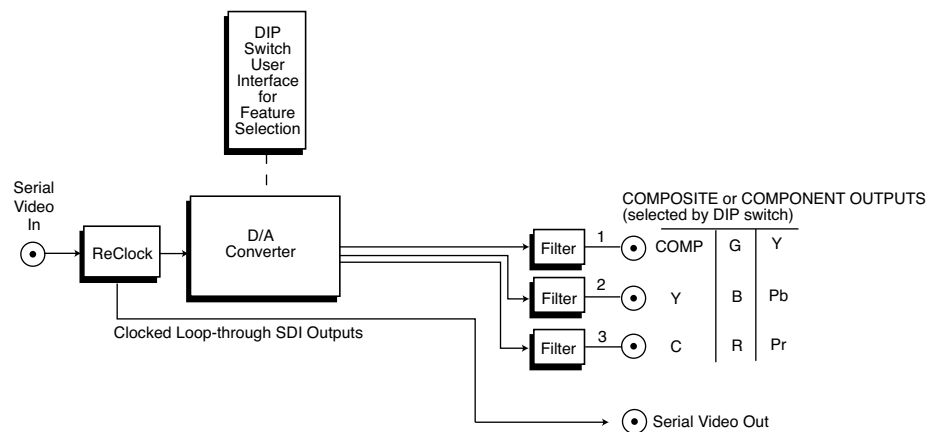

*D5CE SDI to Analog Component and Composite Converter, Block Diagram*

## I/O Connections

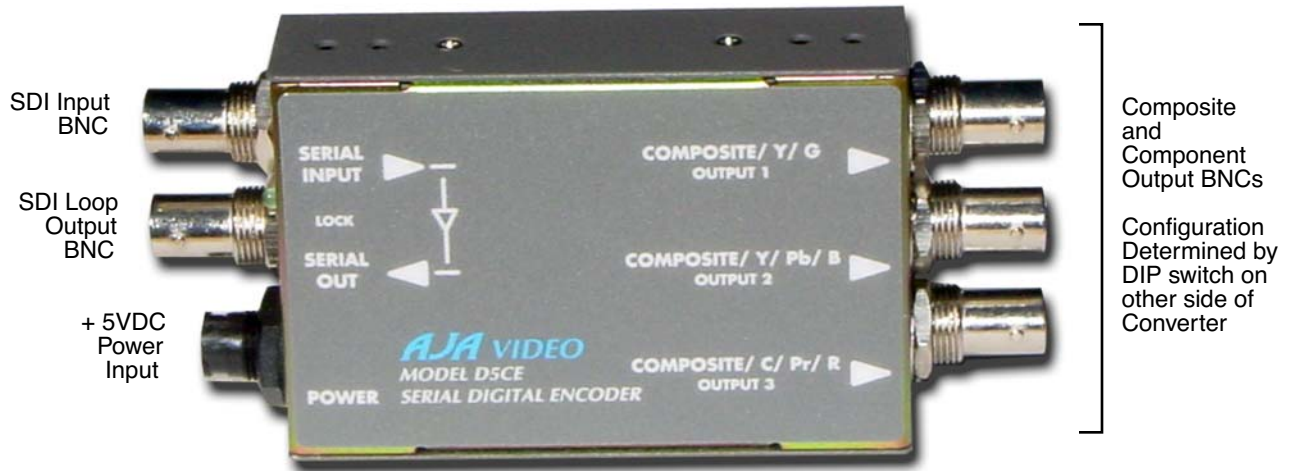

*D5CE, Side View*

## User Controls



DIP Switches

OFF ←→ ON

The user interface for the D5CE is a 4-switch DIP accessible through a cut-out in the bottom of the unit. Use the DIP switches to configure outputs, pedestal, blanking, and choose type of component output (if using component).

Switches 1 and 2 select output BNC video format. Switches 3 and 4 configure pedestal and blanking. The exact function of each DIP switch and what it controls is described on the following pages.

### Switch 1—Selects Composite or Component Video Output (3 BNCs)

ON	OFF
COMPNT: Selects component video output	CMPSTE: Selects composite video output and Y/C output

### Switch 2—Select Video Format of Outputs (3 BNCs)

ON	OFF
YPbPr/YC: If SW1 is set to COMPNT, this selection outputs Y, R-Y, B-Y If SW 1 is set to CMPSTE, this selection outputs 1 composite and 1 Y/C	RGB: If SW1 is set to COMPNT, this selection outputs RGB If SW1 is set to CMPSTE, this selection outputs 3 composites

### Switch 3—Configure Pedestal

ON	OFF, RGB
7.5 IRE pedestal for NTSC (also selects BETA 525 levels for YUV)	No pedestal (also selects SMPTE levels for YUV)

**Note:** There is no effect with 625 input.

### Switch 4—Configure Blanking For Composite/Sync BNC

ON	OFF
WIDE Blanking: Vertical— Line numbers indicate where video starts) line 20, field 1; line 20, field 2 (525 line) line 23, field 1; line 336, field 2 (625 line) Horizontal— Active video line duration ITU-R/SMPTE (710 pixels NTSC, 702 pixels PAL)	NARROW (NAR) Blanking: Vertical— Line numbers indicate where video starts line 13, field 1; line 12, field 2 (525 line) line 10, field 1; line 322, field 2 (625 line) Horizontal— Active video line duration's) ITU-R.470 (720 pixels PAL/NTSC)

### Output Selection Matrix For Output 2 (3 BNCs)

The following table shows the combinations of DIP switch settings required to configure the three output BNCs.

Output Format	DIP Switch #1	DIP Switch #2	DIP Switch #3
3 composite (pedestal)	COMPSTE/ OFF	RGB/OFF	ON
3 composite (no pedestal)	COMPSTE/ OFF	RGB/OFF	OFF
1 composite & 1 Y/C (pedestal)	COMPSTE/ OFF	YUV/YC ON	ON
1 composite & 1 Y/C (no pedestal)	COMPNT/ON	YUV/YC ON	OFF
RGB	COMPNT/ON	RGB/OFF	OFF
SMPTE component (BETA625)	COMPNT/ON	YUV/YC ON	OFF
BETA 525 component	COMPNT/ON	YUV/YC ON	ON

#### Notes:

1. The D5CE is programmed for a 1.3 MHz chroma bandwidth when composite video mode is selected. This provides the best quality video when encoding component digital video. However, with lower cost monitors it may be desirable to reduce the composite chroma bandwidth to 650 KHz to reduce the effects of cross-color artifacts. This option is available from AJA Video as a special order.

2. The encoder's D-to-A chip in the D5CE has an 8-bit input for component digital video and 10-bit D-to-A converters for the analog outputs. This configuration is often described as an 8-bit "signal path" and 10-bit "Quantization." Due to the internal processing of the encoder chip, it is advantageous to use 10-bit D-to-A converters at the output even though the input is 8-bits.

## Installation

Typically, D5CE installation consists of the following:

1. disconnect +5VDC from the convertor
2. configure the DIP switch for the desired equipment configuration and video formats
3. connect video equipment to the convertor BNCs
4. apply +5VDC power to the converter (AJA power supply model DWP)

## Specifications

Item	Specification
Serial Input	SMPTE 259M 270MB, (SDI)
SDI Cable Equalization	300 meter 8281 typical
Serial Output (looping)	Equalized, Re-clocked
Outputs	1. YPbPr - SMPTE, EBU-N10, Betacam, RGB (3 BNCs) 2. NTSC, PAL (3 BNCs) 3. NTSC/PAL and Y/C (3 BNCs)
Frequency Response	+/- .25dbto 5.5Mhz (Y) +/- .25dbto2.0Mhz (Chroma-Component, RGB) +/- .25dbto 1.3Mhz (Chroma - Composite)
2T K factor	< 1% (Y)
Differential Gain	< 1 .5%
Differential Phase	< 1 .5 degree
Y/C delay	10ns maximum
D/A Converters	10 bits
Signal Path	8 bits
Delay (input to output)	1.5us
Output level adjustment	+/- 20% (internal)
Output level matching	1 .5% or 10mv (All outputs are separately buffered)
Power (AJA power supply model DWP)	5v DC regulated, 2.5 watt
Size	5.1" x 2.4" x 1" (131 x 61 x 25 MM.)