

Agilent L4451A 4-Channel Isolated D/A Converter with Memory

Data Sheet



- LXI compliance includes built-in Ethernet connectivity
- Fully-featured graphical Web interface
- Four isolated analog outputs
- Outputs up to ± 16 V or ± 20 mA DC
- 16-bits of resolution
- 200 kHz update rate
- Default standard waveforms
- Software drivers for most common programming environments

4-Channel D/A Converter offers high-voltage analog outputs wherever your application needs it

The Agilent L4451A is a high-performance 4 channel D/A converter that is LXI Class C compliant. With its small size and Ethernet connectivity, the D/A converter can be placed wherever your application needs it.

The Agilent L4451A has four isolated analog channels that are useful to source bias voltages to your device under test, to control your analog programmable power supplies, or use the outputs as setpoints for your control systems. You

can use the standard waveforms provided or create your own with over 500,000 points. These points can be dynamically allocated among one or more channels and output as a point-to-point arb.

Using this LXI instrument, you'll get all the benefits of an Ethernet connection, instrument Web server, standard software drivers and more. The LXI standard is supported by multiple vendors, enabling lower cost of test with accelerated test integration and development.



Isolated analog outputs can be stacked for higher voltage outputs

The L4451A has four independent, isolated channels that can output DC voltage up to ± 16 V or DC current up to ± 20 mA with 16 bits of resolution. The gain and offset can be adjusted on-the-fly. And since these are isolated channels, they can be stacked to create waveforms with higher output voltages.

Each channel can be controlled manually, or use the onboard memory to download a waveform. The 500 k of memory is global and can store up to 32 waveforms. Any waveform can be dynamically allocated among one or more channels and output as a point-to-point arbitrary waveform generator at up to 200 k points/s. You can use the standard sine, square or ramp wave shapes provided or define your own wave shape using over 500,000 points and output to a device under test.

Synchronize your outputs with the CLK that can be divided down for each channel independently.

The L4451A is electronically calibrated using an external DMM and the CAL command.

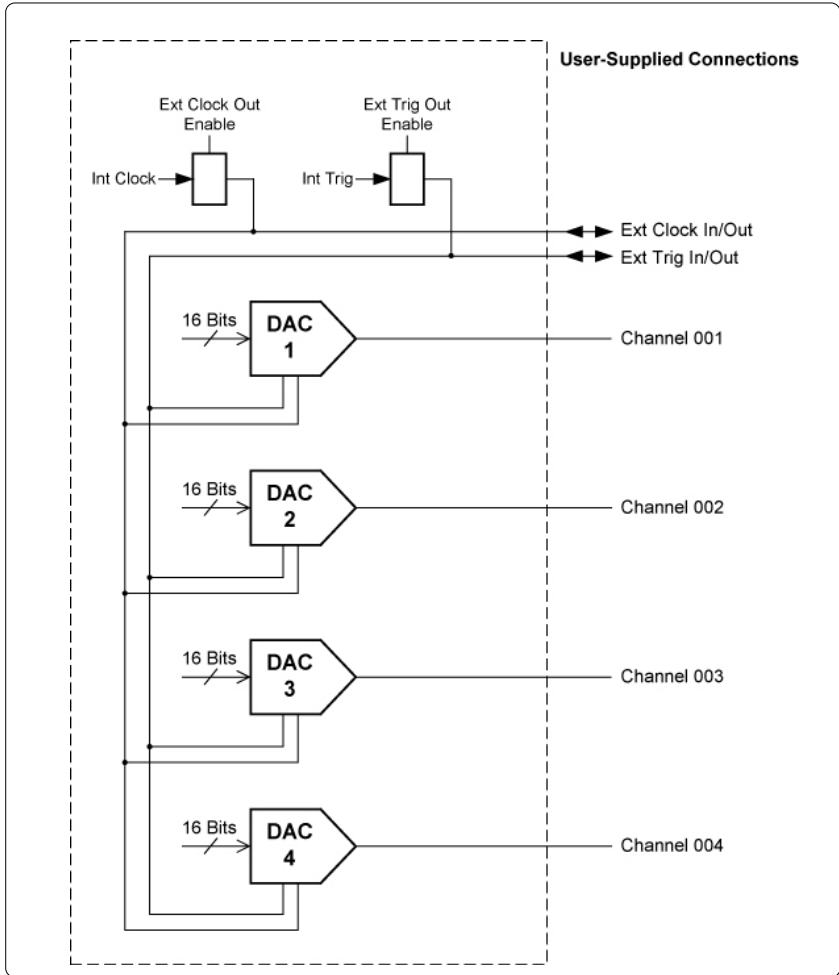

Figure 1. L4451A 4-channel isolated D/A converter

System connections you can trust

The L4451A comes with 1 heavy duty 50-pin Dsub connector that allows for simple, reliable connection options. Each connector uses 30 micro-inches of gold to ensure a repeatable, accurate measurement. Flexible connection options include:

- Detachable terminal blocks with strain relief
- Low-cost, standard 50-pin Dsub connector kits and cables
- Mass interconnect solutions

Ethernet connectivity enables simple connection to the network and remote access to measurements

The Ethernet interface offers high-speed connections that allow for remote access and control. You can set up a private network to filter out unwanted LAN traffic and speed up the I/O throughput, or take advantage of the remote capabilities

and distribute your tests worldwide. Monitor, troubleshoot, or debug your application remotely. Ethernet communication also can be used with the support of LAN sockets connections.

The optional GPIB interface has many years of proven reliability and can be used for easy integration into existing applications.

The L4451A ships with the Agilent E2094N I/O Libraries Suite making it easy for you to configure and integrate instruments into your system – even if your system includes instruments from multiple vendors.

Fully-featured graphical Web interface makes it easy to set-up and troubleshoot your tests from anywhere in the world

The built-in Web browser interface provides remote access and control of the instrument via a Java-enabled browser such as Internet Explorer. Using the Web interface, you can set up, troubleshoot, and maintain your instrument from remote locations.

- View and modify instrument setup
- Configure analog and clock outputs

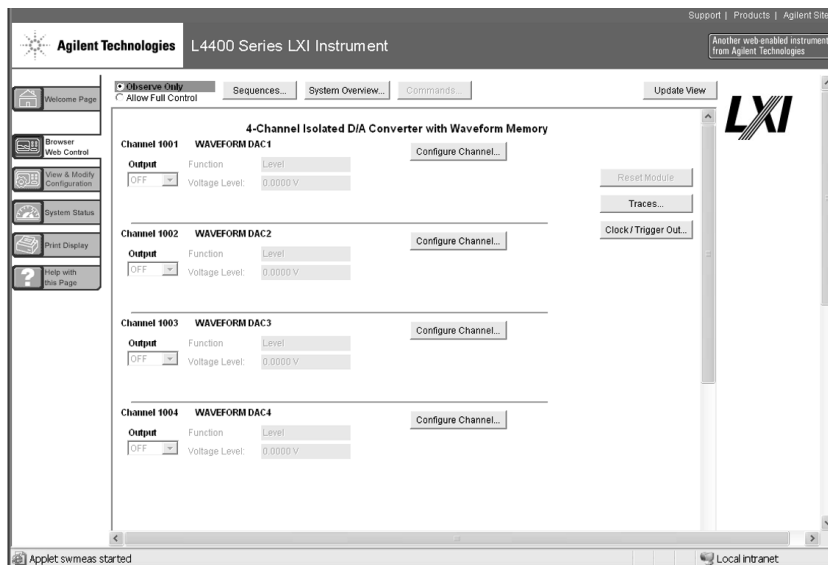

Figure 2. The Web interface makes it easy to set up, troubleshoot and maintain your test remotely

- Define and output waveforms
- View error queue
- Get status reports, current configuration, firmware revisions, and more

Additionally, since the Web server is built into the instrument, you can access it on any operating system that supports the Web browser without having to install any special software. Password protection and LAN lockout are also provided to limit access for additional security.

Software for most popular programming environments

Full support for standard programming environments ensures compatibility and efficiency. You can use direct I/O with the software you already have and know, or use standard IVI and LabVIEW™ software drivers that provide compatibility with the most popular development environments:

- Agilent T&M Toolkit for Microsoft Visual Studio®.NET and Agilent VEE Pro
- National Instruments LabVIEW, LabWindows/CVI, TestStand, and Switch Manager
- Microsoft C/C++® and Visual Basic®

High-performance digital I/O wherever your application needs it



Power button

Status LEDs

Easy connection options with terminal blocks, standard 50-pin cables or connector kits

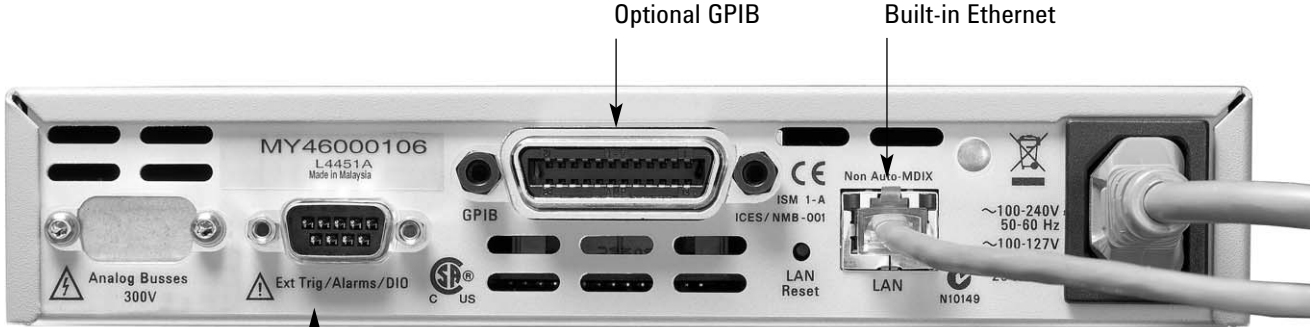

Optional GPIB

Built-in Ethernet

External trigger to synchronize events

Product Specifications

Specifications and Characteristics

Output specifications	Maximum update rate:	200 kHz point-to-point
	Monotonic :	to 16-bits
	Isolation:	> 80 VDC/AC peak (chan-to-chassis or chan-to-chan)
	Synchronization:	Software commands or external trigger
	Internal/external CLK accuracy:	100 ppm
	AC accuracy:	Not specified

DC voltage

Amplitude:	± 16 V up to 10 mA
Resolution:	16-bit = 500 μ V
Amplitude Accuracy (DC):	$\pm(0.05\% + 3.0$ mV
Ripple and noise:	< 2 mVrms, 20 Hz to 250 kHz into 10 k Ω load
Settling time:	40 μ s (-full scale to +full scale step, single channel, to rated accuracy)
Output impedance:	< 1 Ω with the load sensed

DC current

Range:	± 20 mA
Resolution:	16-bit = 630 nA
Accuracy:	$\pm(\%$ value + amps) (temperature within $\pm 5^\circ$ C of Tcal or *Cal?) 90-day: $\pm(0.09\% + 5.0$ μ A)
Ripple and noise:	< 2 μ Arms, 20 Hz to 250 kHz into 250 Ω
Compliance voltage:	± 12 V
Max open circuit voltage:	< ± 22 V

Product Specifications (continued)

Phase-locking I/O trigger characteristics

Trigger input	Input level:	TTL compatible (3.3 V logic, 5 V tolerant)
	Slope:	Rising or falling, selectable
	Pulse width:	> 100 ns
	Input impedance:	> 10 k Ω , DC coupled
Trigger output	Level:	TTL compatible into 1 k Ω (3.3 V logic)
	Output impedance:	50 Ω typical
Clock input	Input level:	TTL compatible (3.3 V logic, 5 V tolerant)
	Input impedance:	> 10 k Ω , DC
	Maximum rate:	10 MHz
Clock output	Level:	TTL compatible Into 1 k Ω (3.3 V logic)
	Output impedance:	50 Ω typical
	Maximum rate:	10 MHz
	Accuracy:	\pm 100 ppm

Memory

Type	Volatile
Size	500 K for waveforms
States	5 instrument states with user label in non-volatile memory

General specifications

Power supply	Universal 100 V to 240 V \pm 10%
Power line frequency	50 Hz to 60 Hz \pm 10% automatically sensed
Power consumption	15 VA
Operating Environment	Full accuracy for 0°C to 55°C Full accuracy to 80% R.H. at 40 °C
Storage environment	-40°C to 70°C
Dimensions (H x W x L)	40.9 x 212.3 x 379.3 mm 1.61 x 8.36 x 14.93 in
Weight	3.7 kg, 8.2 lbs
Safety conforms to	CSA, UL/IEC/EN 61010-1
EMC conforms to	IEC/EN 61326-1, CISPR 11
Warranty	1 year

Product Specifications (continued)

Software

Agilent connectivity software included	Agilent I/O Libraries Suite 14 or greater (E2094N)
--	--

Minimum system requirements

PC hardware	Intel Pentium 100 MHz, 64 Mbyte RAM, 210 Mbyte disk space Display 800x600, 256 colors, CD-ROM drive
Operating system ¹	Windows [®] 98 SE/NT/2000/XP

Computer interfaces

Standard LAN 10BaseT/100BaseTx
Optional IEEE 488.2 GPIB

Software driver support for programming languages

Software drivers	IVI-C and IVI-COM for Windows NT [®] /2000/XP LabVIEW
------------------	---

Compatible with programming tools and environments

Agilent	VEE Pro T&M Toolkit (reqs Visual Studio.NET)
National Instruments	TestStand Measurement Studio LabWindows/CVI LabVIEW Switch Executive
Microsoft	Visual Studio.NET [®] C/C++ Visual Basic 6 [®]

¹ Load I/O Libraries Version M for Windows NT support or version 14.0 for Windows 98 SE support

Ordering information

L4451A 4-Channel Isolated D/A

Converter with Memory

Includes User's guide on CD, power cord, and Quick Start package

Option - GPIB

Adds GPIB interface

Option 0B0

Deletes printed manual set, full documentation included on CD ROM

Option ABA

English printed manual set

Connection Options

Select terminal block for discrete wiring, cables or connector kits. Cables and connector kits require one per instrument.

34951T

Terminal block for 34951A and L4451A 4-Ch D/A Converter

Y1135A

1.5 m 50-pin Dsub, M/F twisted pair with outer shield cable – 300 V

Y1136A

3 m 50-pin Dsub, M/F twisted pair with outer shield cable – 300 V

Y1141A

Solder cup connector kit with male 50-pin Dsub

Other accessories

Y1160A

Rack mount kit for

L4400 series instruments- racks 2 instruments side-by-side on sliding tray

For additional information please visit:

<http://www.agilent.com/find/L4451A>

Related Agilent literature

Data Sheets

5988-6302EN

Agilent VEE Pro

5989-1441EN

Agilent W1140A-TKT

T&M Toolkit 2.0 with Test Automation

5989-1439EN

Agilent E2094N

I/O Libraries Suite 14

Agilent Technologies' Test and Measurement Support, Services, and Assistance

Agilent Technologies aims to maximize the value you receive, while minimizing your risk and problems. We strive to ensure that you get the test and measurement capabilities you paid for and obtain the support you need. Our extensive support resources and services can help you choose the right Agilent products for your applications and apply them successfully. Every instrument and system we sell has a global warranty. Two concepts underlie Agilent's overall support policy: "Our Promise" and "Your Advantage."

Our Promise

Our Promise means your Agilent test and measurement equipment will meet its advertised performance and functionality. When you are choosing new equipment, we will help you with product information, including realistic performance specifications and practical recommendations from experienced test engineers. When you receive your new Agilent equipment, we can help verify that it works properly and help with initial product operation.

Your Advantage

Your Advantage means that Agilent offers a wide range of additional expert test and measurement services, which you can purchase according to your unique technical and business needs. Solve problems efficiently and gain a competitive edge by contracting with us for calibration, extra-cost upgrades, out-of-warranty repairs, and on-site education and training, as well as design, system integration, project management, and other professional engineering services. Experienced Agilent engineers and technicians worldwide can help you maximize your productivity, optimize the return on investment of your Agilent instruments and systems, and obtain dependable measurement accuracy for the life of those products.



Agilent Email Updates

www.agilent.com/find/emailupdates

Get the latest information on the products and applications you select.



Agilent Direct

www.agilent.com/find/agilentdirect

Quickly choose and use your test equipment solutions with confidence.



Agilent Open

www.agilent.com/find/open

Agilent Open simplifies the process of connecting and programming test systems to help engineers design, validate and manufacture electronic products. Agilent offers open connectivity for a broad range of system-ready instruments, open industry software, PC-standard I/O and global support, which are combined to more easily integrate test system development.



Agilent Technologies