

Agilent L4450A 64-Bit Digital I/O with Memory and Counter

Data Sheet

- LXI compliance includes built-in Ethernet connectivity
- Fully-featured graphical Web interface
- 64 bi-directional digital I/O bits with programmable polarity
- Variable thresholds from 0 V to 5 V
- Handshaking protocols
- Source/sink current up to 24 mA
- 128 kbytes pattern memory
- Two 10 MHz counter channels
- 20 MHz divide-by-n clock
- Software drivers for most common programming environments



64-bit Digital I/O offers high-performance digital I/O wherever your application needs it

The Agilent L4450A is a high-speed 64-bit digital I/O instrument that is LXI Class C compliant. With its small size and Ethernet connectivity, the Digital I/O can be placed wherever your application needs it.

The Agilent L4450A has 64 bi-directional lines configured as eight 8-bit channels. Each 8-bit channel has programmable polarity and thresholds up to 5 V. The 128 k of memory is useful for simulating and capturing digital patterns up to 10 MHz. The configurable handshaking protocols can be used for a wide variety of applications.

In addition, the two counter channels can be used to count events, frequency, period, duty cycle, pulse width and totalize.

Using this LXI instrument, you'll get all the benefits of an Ethernet connection, instrument Web server, standard software drivers and more. The LXI standard is supported by multiple vendors, enabling lower cost of test with accelerated test integration and development.



Digital inputs and outputs for your most complicated digital applications

The L4450A can be used to simulate or detect digital patterns. It has eight 8-bit digital I/O channels with handshaking, pattern memory, two 10 MHz counters with gate functions, and a programmable clock output.

Digital input/output

The digital I/O bits are organized into two banks of 32-bits. The I/O bits can be configured and programmed as inputs or outputs in 8-bit channels. The digital outputs can be configured as active drive or open drain outputs with a user supplied 10 kΩ pull up. User supplied pull-up resistors for up to 5 V outputs are also acceptable. The digital inputs have programmable thresholds up to 5 V for compatibility with most digital logic standards. The on-board pattern memory can be used to select and output digital stimulus or bit stream patterns, or to capture external digital data. Each bank has independent memory and directional control so that one bank can output data while another captures data. The memory can be divided up to 64 kbytes per 8-bit channel.

The memory can be allocated as follows:

	Default Configuration	Memory on Channels 1 & 2	Memory on Channel 1
Channel 1/5 (Bits 7:0) (Bits 39:32)	32 kbytes	64 kbytes	64 kbytes
Channel 2/6 (Bits 15:8) (Bits 47:40)	32 kbytes	64 kbytes	
Channel 3/7 (Bits 23:16) (Bits 55:48)	32 kbytes		
Channel 4/8 (Bits 31:24) (Bits 63:56)	32 kbytes		

The digital channels also have:

- Variable active high drive output from 1.65 V to 5 V or open drain
- Variable input thresholds from 0 V to 5 V
- Configurable handshaking protocols including synchronous and strobe
- Programmable polarity
- Source or sink up to 24 mA

- Internal alarming for maskable pattern match
- 1 hardware pattern interrupt per bank

External trigger capabilities make it easy for you to time and synchronize measurements and other events. This can help you determine when to begin or end an acquisition.

Frequency counter and totalizer

The two channels can be used to count digital events, frequency, period, duty cycle, pulse width and totalize. The counter/totalizer also includes:

- Programmable gate functionality
- Programmable input thresholds levels 0 V to 3 V

System connections you can trust

The L4450A comes with 2 heavy duty 78-pin Dsub connectors that allow for simple, reliable connection options. Each connector uses 30 micro-inches of gold to ensure a repeatable, accurate measurement. Flexible connection options include:

- Detachable terminal blocks with strain relief
- Low-cost, standard 78-pin Dsub connector kits and cables
- Mass interconnect solutions

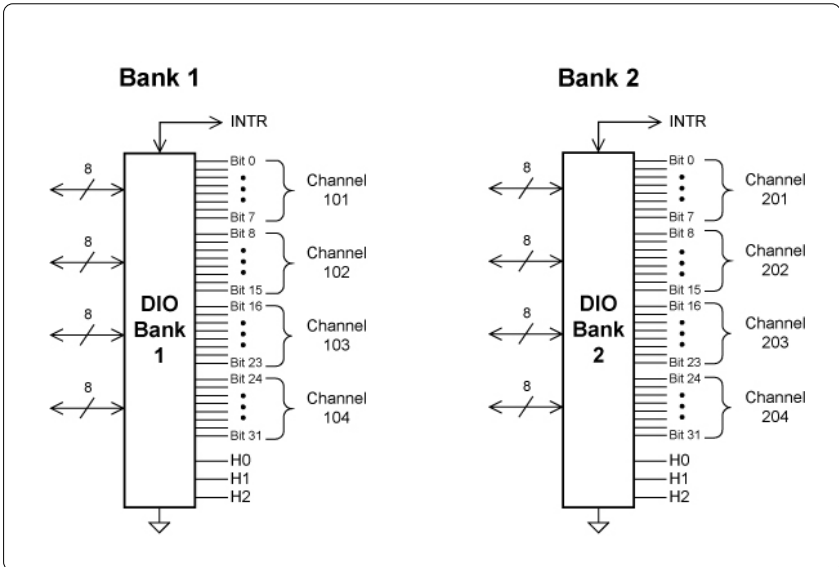

Figure 1. L4450A 64-bit digital I/O with counter

Ethernet connectivity enables simple connection to the network and remote access to measurements

The Ethernet interface offers high-speed connections that allow for remote access and control. You can set up a private network to filter out unwanted LAN traffic and speed up the I/O throughput, or take advantage of the remote capabilities and distribute your tests worldwide. Monitor, troubleshoot, or debug your application remotely. Ethernet communication also can be used with the support of LAN socket connections.

The optional GPIB interface has many years of proven reliability and can be used for easy integration into existing applications.

The L4450A ships with the Agilent E2094N I/O Libraries Suite making it easy for you to configure and integrate instruments into your system—even if your system includes instruments from multiple vendors.

Fully-featured graphical web interface makes it easy to set-up and troubleshoot your tests from anywhere in the world

The built-in Web browser interface provides remote access and control of the instrument via a Java-enabled browser such as Internet Explorer. Using the Web interface, you can set up, troubleshoot, and maintain your instrument from remote locations.

- View and modify instrument setup
- Configure I/O channels, patterns and alarms
- Read and write I/O channels
- Load and step digital patterns
- Define handshaking and memory allocation
- View error queue
- Get status reports, current configuration, firmware revisions, and more

Additionally, since the Web server is built into the instrument, you can access it on any operating system that supports the Web browser without having

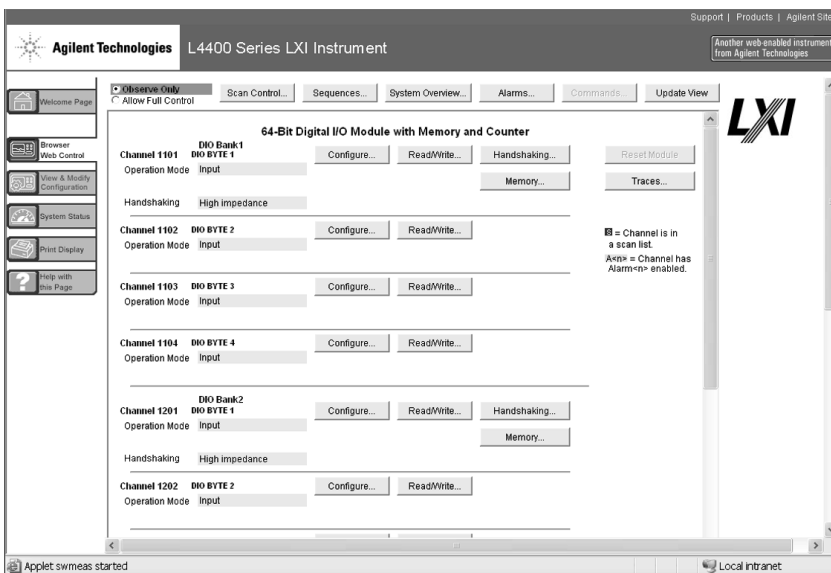

Figure 2. The Web interface makes it easy to set up, troubleshoot and maintain your test remotely

to install any special software. Password protection and LAN lockout are also provided to limit access for additional security.

Software for most popular programming environments

Full support for standard programming environments ensures compatibility and efficiency. You can use direct I/O with the software you already have and know, or use standard IVI and LabVIEW™

software drivers that provide compatibility with the most popular development environments:

- Agilent T&M Toolkit for Microsoft Visual Studio® .NET and Agilent VEE Pro
- National Instruments LabVIEW, LabWindows/CVI, TestStand, and Switch Manager
- Microsoft C/C++® and Visual Basic®

High-performance digital I/O wherever your application needs it

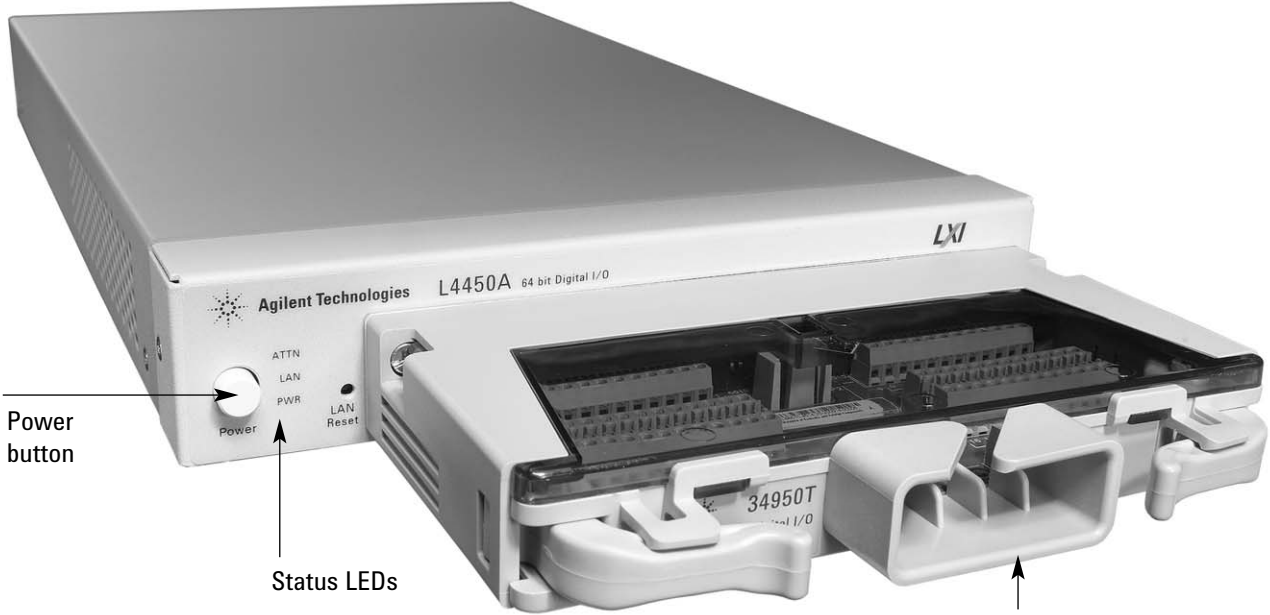

Power button

Status LEDs

Easy connection options with terminal blocks, standard 78-pin cables or connector kits

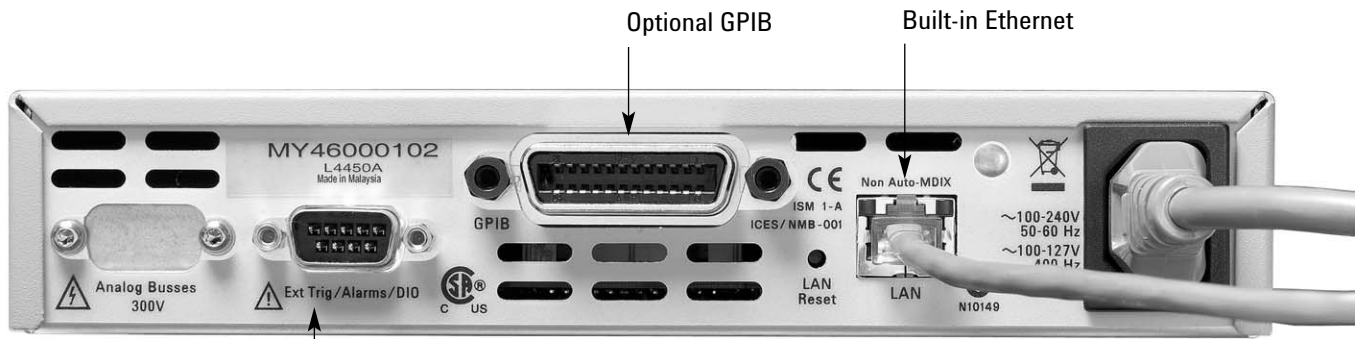

Optional GPIB

Built-in Ethernet

External trigger to synchronize events

Product Specifications

Specifications and Characteristics

Digital input/output characteristics

Eight 8-bit channels: 8 bits wide, input or output, non-isolated

Vin	0 V – 5 V ¹
Vout	1.65 V – 5 V ^{1,2}
Iout (max)	24 mA ²
Frequency (max)	10 MHz ³
ILoad (max)	400 mA
tr + tf (typ)	6 ns ⁵

Handshake lines

Vin	0 – 5 V ⁴
Vout	1.65 – 5 V ^{2,4}
I out (max)	24 mA ²
Frequency (max)	10 MHz

Counter function characteristics

Maximum freq	10 MHz (max) 50% duty cycle
Vin	0 V – 5 V

Totalizer function characteristics

Maximum count	2 ³² – 1 (4,294,967,296)
Max input freq	10 MHz (max), rising or falling edge programmable
Vin	0 V – 5 V
Gate input	0 V – 5 V

System clock generator characteristics

Frequency	20 MHz – 10 Hz configurable divide-by-n 24-bits, programmable on/off
Vout	1.65 V – 5 V ²
Accuracy	100 ppm

¹ Configurable by 8-bit channel
² Lower current drive at lower voltages
³ From memory with handshaking
⁴ Configurable by bank
⁵ 5 V, 50 pF load

Product Specifications (continued)

Data out of memory to LAN or GPIB

(data transfer rate with 1000 channel blocks)	GPIB rds/s	LAN (w/ VXI 11) rds/s
Readings	2560	3542
readings with timestamp	1304	1826
readings with all format options ON	980	1361

Scan triggering

Source	Interval, external, software, or on monitor channel alarm
Scan count	1 to 50,000 or continuous
Scan interval	0 to 99 hours; 1 ms step size
Channel delay	0 to 60 seconds per channel; 1 ms step size
External trig delay	<2 ms. With monitor on <200 ms
External trig jitter	<2 ms

Alarms

Digital inputs	digital in maskable pattern match or state change frequency and totalize: Hi limit only
Alarm on channel	Alarm evaluated each reading
Alarm outputs	2 TTL compatible Selectable TTL logic Hi or Lo on fail
Latency	5 ms (typical)

Memory

Type	Volatile
Size	128 kbytes for digital patterns
States	5 instrument states with user label in non-volatile memory

General specifications

Power supply	Universal 100 V to 240 V $\pm 10\%$
Power line frequency	50 Hz to 60 Hz $\pm 10\%$ automatically sensed
Power consumption	15 VA
Operating Environment	Full accuracy for 0°C to 55°C Full accuracy to 80% R.H. at 40 °C
Storage environment	-40°C to 70°C
Dimensions (H x W x L)	40.9 x 212.3 x 379.3 mm 1.61 x 8.36 x 14.93 in
Weight	3.7 kg, 8.2 lbs
Safety conforms to	CSA, UL/IEC/EN 61010-1
EMC conforms to	IEC/EN 61326-1, CISPR 11
Warranty	1 year

Product Specifications (continued)

Software

Agilent connectivity software included	Agilent I/O Libraries Suite 14 or greater (E2094N)
--	--

Minimum system requirements

PC hardware	Intel Pentium 100 MHz, 64 Mbyte RAM, 210 Mbyte disk space Display 800x600, 256 colors, CD-ROM drive
Operating system ¹	Windows [®] 98 SE/NT/2000/XP

Computer interfaces

Standard LAN 10BaseT/100BaseTx
Optional IEEE 488.2 GPIB

Software driver support for programming languages

Software drivers	IVI-C and IVI-COM for Windows NT [®] /2000/XP LabVIEW
------------------	---

Compatible with programming tools and environments

Agilent	VEE Pro T&M Toolkit (reqs Visual Studio.NET)
National Instruments	TestStand Measurement Studio LabWindows/CVI LabVIEW Switch Executive
Microsoft	Visual Studio.NET [®] C/C++ Visual Basic 6 [®]

¹ Load I/O Libraries Version M for Windows NT support or version 14.0 for Windows 98 SE support

Ordering information

L4450A 64-bit Digital I/O

with memory and counter

Includes User's guide on CD, power cord, and Quick Start package

Option - GPIB

Adds GPIB interface

Option 0B0

Deletes printed manual set, full documentation included on CD ROM

Option ABA

English printed manual set

Connection Options

Select terminal block for discrete wiring, cables or connector kits. Cables and connector kits require 2 per instrument.

34950T

Terminal block for 34950A and L4450A 64-bit Digital I/O

Y1137A

1.5 m 78-pin Dsub, M/F twisted pair with outer shield cable – 300 V

Y1138A

3 m 78-pin Dsub, M/F twisted pair with outer shield cable – 300 V

Y1142A

Solder cup connector kit with male 78-pin Dsub

Other accessories

Y1160A

Rack mount kit for

L4400 series instruments- racks 2 instruments side-by-side on sliding tray

For additional information please visit:

<http://www.agilent.com/find/L4450A>

Related Agilent literature

Data Sheets

5988-6302EN

Agilent VEE Pro

5989-1441EN

Agilent W1140A-TKT

T&M Toolkit 2.0 with

Test Automation

5989-1439EN

Agilent E2094N

I/O Libraries Suite 14

Agilent Technologies' Test and Measurement Support, Services, and Assistance

Agilent Technologies aims to maximize the value you receive, while minimizing your risk and problems. We strive to ensure that you get the test and measurement capabilities you paid for and obtain the support you need. Our extensive support resources and services can help you choose the right Agilent products for your applications and apply them successfully. Every instrument and system we sell has a global warranty. Two concepts underlie Agilent's overall support policy: "Our Promise" and "Your Advantage."

Our Promise

Our Promise means your Agilent test and measurement equipment will meet its advertised performance and functionality. When you are choosing new equipment, we will help you with product information, including realistic performance specifications and practical recommendations from experienced test engineers. When you receive your new Agilent equipment, we can help verify that it works properly and help with initial product operation.

Your Advantage

Your Advantage means that Agilent offers a wide range of additional expert test and measurement services, which you can purchase according to your unique technical and business needs. Solve problems efficiently and gain a competitive edge by contracting with us for calibration, extra-cost upgrades, out-of-warranty repairs, and on-site education and training, as well as design, system integration, project management, and other professional engineering services. Experienced Agilent engineers and technicians worldwide can help you maximize your productivity, optimize the return on investment of your Agilent instruments and systems, and obtain dependable measurement accuracy for the life of those products.



Agilent Email Updates

www.agilent.com/find/emailupdates

Get the latest information on the products and applications you select.



Agilent Direct

www.agilent.com/find/agilentdirect

Quickly choose and use your test equipment solutions with confidence.



Agilent Open

www.agilent.com/find/open

Agilent Open simplifies the process of connecting and programming test systems to help engineers design, validate and manufacture electronic products. Agilent offers open connectivity for a broad range of system-ready instruments, open industry software, PC-standard I/O and global support, which are combined to more easily integrate test system development.



Agilent Technologies