

[Visit us at www.TestEquipmentDepot.com](http://www.TestEquipmentDepot.com)

[Back to the Agilent 1160A Product Info Page](#)

---

## User's Guide



For safety information, regulatory information, and publishing information, see the pages at the back of this book.

© Copyright Agilent Technologies, Inc. 1998-2006  
All Rights Reserved.

---

# Agilent 1160 Series Miniature Passive Oscilloscope Probes

---

# Introduction

The Agilent 1160-series family of miniature passive probes offers modular construction and reliability. Modular construction allows individual replacement of probe tips. Improved cable and strain relief design increase reliability.

The Agilent 1160-series probes are compatible with the AutoProbe Interface, which completely configures the Infiniium oscilloscope for the probe. The snap-on BNC connector makes it easy to attach the probe to the oscilloscope. When using a 50  $\Omega$  oscilloscope, you must also use an Agilent E2697A 1 M $\Omega$  adapter.

Agilent Technologies miniature probes significantly reduce the problem of probing densely populated integrated circuit components or the characteristically minute conductors on printed circuit boards. These small, lightweight probes allow measurements that were previously very difficult, while reducing the hazard of shorting. The probe body fits in the hand as comfortably as a pencil.

The probe includes a browser tip that won't slip off the test point being probed and short to some adjacent point. The browser uses a crown point that "digs in" to solder, and won't slip.

These probes include a variety of accessories for attaching to many different signal and ground points. Other optional accessories are also available.

---

# Contents

To inspect the probe	4
Features	5
Probe parts supplied	5
Ordering replacement parts	5
Available accessories	8
Characteristics	10
Bandwidth considerations	12
Safety considerations	13
To clean the probe	13
To connect oscilloscope probes	14
To operate the probe	15
Compensation adjustments	18

## To inspect the probe

❑ **Inspect the shipping container for damage.**

Keep a damaged shipping container or cushioning material until the contents of the shipment have been checked for completeness and the probe has been checked mechanically and electrically.

❑ **Check the accessories.**

See “Probe parts supplied” on page -5 for a list of accessories supplied with the probe.

- If the contents are incomplete or damaged notify your Agilent Technologies sales office.

❑ **Inspect the instrument.**

- If there is mechanical damage or defect, or if the probe does not operate properly or pass performance tests, notify your Agilent Technologies sales office.
- If the shipping container is damaged, or the cushioning materials show signs of stress, notify the carrier as well as your Agilent Technologies sales office. Keep the shipping materials for the carrier's inspection. The Agilent Technologies office will arrange for repair or replacement at Agilent Technologies's option without waiting for claim settlement.

---

## Features

- Narrow, sharp, replaceable probe tip
- Browser attachment with ultra sharp crown point. Use this attachment when probing about the circuit in debug mode. The crown point will not easily slip off the lead you are probing. The pogo pin allows hand movement without losing contact.
- Snap-on BNC connector makes it easier to attach the probe to the scope
- An assortment of accessories for connecting to a wide variety of points.
- Handle unscrews and pulls back to reduce the size of the probe
- General purpose retractable hook tip constructed of strong, durable music wire
- Flexible, light weight cable with kevlar strengthener
- Multi-position barrel insulator exposes as much or as little probe ground as desired at the probe tip.
- The manual provides information on how to order replacement parts and optional accessories.
- Automatic Probe Identification Pin

---

## Probe parts supplied

The following figure and table show the parts supplied with the Agilent 1160 series probe. The replaceable parts table shows replacement and optional parts that can be ordered from Agilent Technologies.

### **Ordering replacement parts**

To order a replacement part, in the United States please call our toll-free hotline at 1-877-447-7278, or call you local Agilent Technologies Sales Office.

Agilent 1160 Series Miniature Passive Oscilloscope Probes  
**Probe parts supplied**

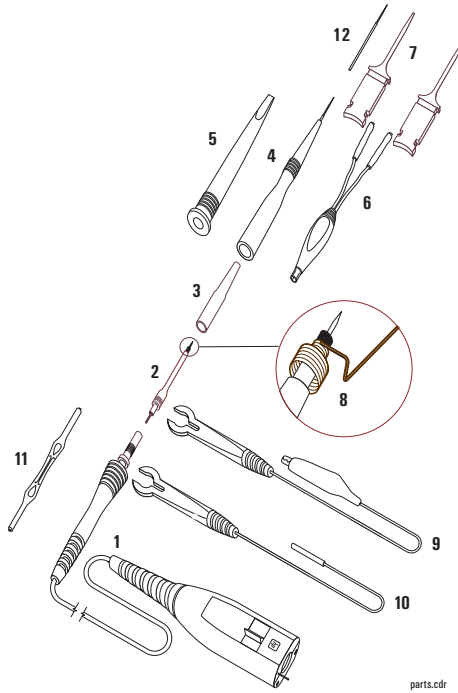

parts.cdr

**Probe Parts Supplied**

Item #	Description	Qty Supplied
1	Probe	1
2	Probe tip	2
3	Barrel insulator	2
4	Browser	1
5	General purpose retractable hook tip	1
6	Dual-lead adapter	1
7	SMD clip	2
8	Spring ground	4
9	Alligator ground lead	1
10	Socketed ground lead	1
11	Screwdriver	1
12	Browser pogo pin (spare)	1

The following table shows accessories that you can order from Agilent Technologies. In the United States call our toll-free hotline at 1-800-452-4844, or call your local Agilent Technologies Sales Office.

---

**Replacement and Optional Parts**

---

Item #	Replacement part	Agilent Part Number
1	Probe (for replacement, order entire probe assembly)	1160A, 1161A, 1162A, 1163A, or 1165A
2	1160A probe tip (qty 5) — Red	5063-2136
2	1161A probe tip (qty 5) — Brown	5063-2137
2	1162A probe tip (qty 5) — Black	5063-2138
2	1163A probe tip (qty 5) — Grey	5063-2139
2	1165A probe tip (qty 5) — Brown	5063-2137
3	Barrel insulator (qty 4)	*5063-2129
4	Browser (qty 1)	5063-2115
5	General purpose retractable hook tip (qty 2)	5063-2135
6	Dual-lead adapter (qty 1)	5063-2147; See ** below
7	SMD clip (qty 5)	5063-2149
8	Spring ground (qty 4)	*5063-2148
9	Alligator ground lead (qty 2)	5063-2140
10	Socketed ground lead (qty 1)	5063-2120
11	Screwdriver	*5042-1777
12	Browser pogo pin (qty 4)	*
—	Accessory kit*	01160-68701

\* The accessory kit includes 4 spring grounds, 4 browser pogo pins, 4 barrel insulators, and 1 screw driver.

\*\* Provides interface with the Agilent Wedges.

## Available accessories

- Agilent 10467-68701 SMD microclips, 2 yellow and 2 green, for connection to SMT parts with lead spacings of 0.5mm (0.020 inch) to 0.8mm (0.032 inch)
- Agilent 5063-2143 probe tip-to-BNC adapter.
- Agilent 0960-0301 BNC(m)-to-BNC(f) 50Ω feedthrough terminator.
- Agilent N2767-68701 (Qty 5) or Agilent N2768A (Qty 25) vertical mini-probe socket

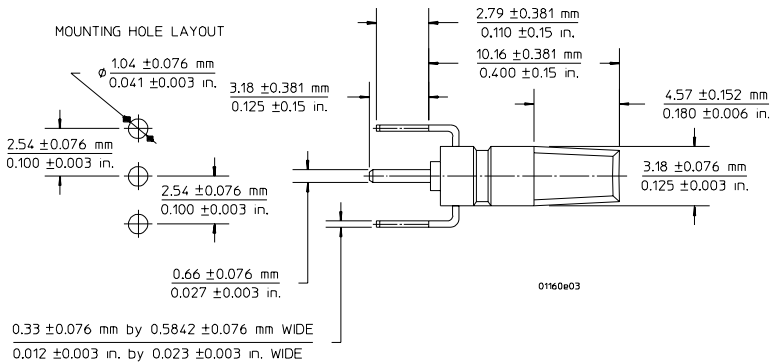

Agilent 1160 Series Miniature Passive Oscilloscope Probes  
**Available accessories**

- Agilent N2765-68701 (Qty 5) or Agilent N2766A (Qty 25) horizontal mini-probe socket.

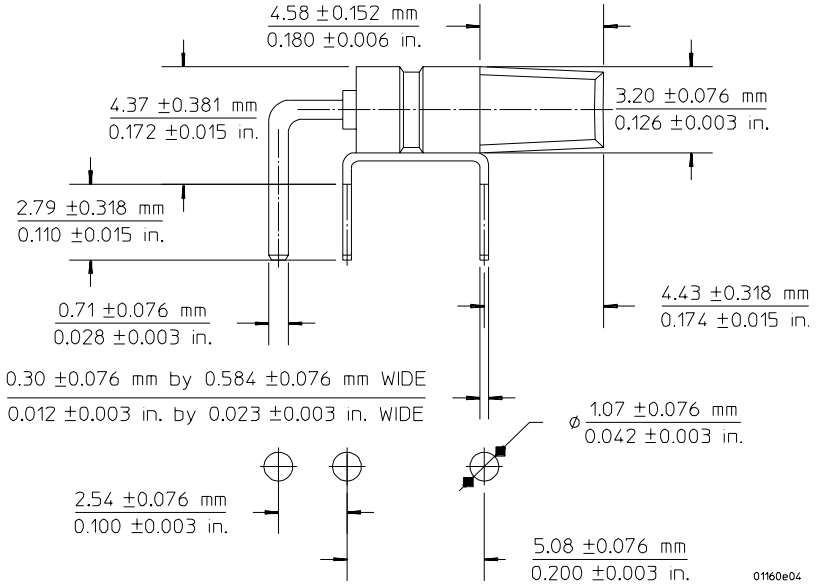

---

## Characteristics

Operating and environmental characteristics are shown below.

---

### Operating Characteristics

<b>Approximate propagation delay 1160A, 1161A, 1162A, 1163A and 1165A</b>	6.7 ns
<b>Approximate propagation delay (1164A)</b>	8.8 ns
<b>Safety</b>	Meets IEC1010-2-31
<b>Pull strength (BNC to probe tip)</b>	≤12 lb static pull
<b>Maximum input voltage</b>	Except 1163A: 300 V (dc + peak ac), CAT II 1163A: 10 V (dc+ peak ac), CAT I

### Voltage vs Frequency Rating Curve

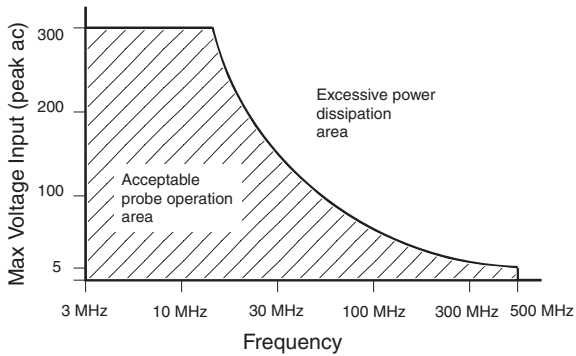

---

### Environmental Characteristics

<b>Temperature (operating)</b>	0 °C to +55 °C
<b>Humidity (operating)</b>	Up to 95% relative humidity at 40 °C
<b>Altitude (operating)</b>	Up to 4,600 meters (15,000 ft)
<b>Shock</b>	50 g (400 g tip only)
<b>Weight</b>	2.6 oz
<b>Indoor Use</b>	



This symbol indicates that the Agilent 1160A Series Probes are in compliance with European product regulations, including the EMC Directive and the Low Voltage Directive.



This symbol indicates that the Agilent 1160A Series Probes are in compliance with Australian product regulations.

### **CAT I and CAT II Definitions**

Installation category (overvoltage category) I: Signal level, special equipment or parts of equipment, telecommunication, electronic etc., with smaller transient overvoltages than installation category (overvoltage category) II.

Installation category (overvoltage category) II: Local level, appliances, portable equipment etc., with smaller transient overvoltages than installation category (overvoltage category) III.

**Bandwidth considerations****Bandwidth considerations**

The Agilent 1160-series probes span four bandwidths.

- The 1160A, 1161A, and, 1164A are designed for use with oscilloscopes having bandwidths up to 500 MHz.
- The 1165A is designed for use with oscilloscopes having bandwidths up to 600 MHz.
- The 1162A is designed for use in measurements demanding maximum sensitivity and bandwidth up to 25 MHz.

The dominant probe limitation to system bandwidth is its input capacitance, assuming the high-frequency compensation adjustments have been made. Displayed bandwidth of any measurement system using an oscilloscope and probe is determined by four factors: probe input capacitance, source impedance, source bandwidth, and oscilloscope bandwidth.

- The system bandwidth when using the 1163A (500 $\Omega$  probe) with a 50 $\Omega$  test source is generally the bandwidth of the oscilloscope.

**Agilent 1160 family selection guide**

Model Number	Type of probe	Bandwidth scope/probe system	Division ratio	Input R	Input C	Scope Input R	Comp Range	Length
1160A	High impedance, passive	500 MHz	10:1	10 M $\Omega$	9 pF	1 M $\Omega$	6–9 pF	1.5 m
1161A	High impedance, passive	500 MHz	10:1	10 M $\Omega$	10 pF	1 M $\Omega$	12–14 pF	1.5 m
1162A	High impedance, passive	25 MHz	1:1	1 M $\Omega$	50 pF + scope capacitance	1 M $\Omega$	n/a	1.5 m
1163A	500 $\Omega$ resistive divider	>1.5 GHz with 54845B	10:1	500 $\Omega$	1.5 pF	50 $\Omega$	n/a	1.5 m
1164A	High impedance, passive	500 MHz	10:1	10 M $\Omega$	10.5 pF	1 M $\Omega$	6–9 pF	2.0 m
1165A	High impedance, passive	600 MHz	10:1	10 M $\Omega$	10 pF	1 M $\Omega$	12–14 pF	1.5 m

NOTE: An E2697A 1 M $\Omega$  input adapter is required to use this probe with a 50  $\Omega$  oscilloscope. The E2697A includes one 10073C general purpose 100 MHz, 10:1 passive probe.

---

**Probe compatibility**

---

<b>Infiniium Oscilloscope</b>	<b>Compatible 1160 Series Probe</b>	<b>Infiniium Oscilloscope</b>	<b>Compatible 1160 Series Probe</b>
54810A	1160A, 1162A, 1163A, 1164A	54833A/D	1162A, 1163A, 1165A
54815A	1160A, 1162A, 1163A, 1164A	54835A	1161A, 1162A, 1163A
54820A	1160A, 1162A, 1163A, 1164A	54845A/B	1161A, 1162A, 1163A
54825A	1160A, 1162A, 1163A, 1164A	54846A/B	1161A, 1162A, 1163A
54830B/D	1162A, 1163A, 1165A	MSO/DSO8104A	1162A, 1163A, 1165A
54831B/D	1162A, 1163A, 1165A	MSO/DSO8064A	1162A, 1163A, 1165A
54832B/D	1162A, 1163A, 1165A		

---

**Safety considerations**

**WARNING SHOCK HAZARD!**

These probes are designed for use with oscilloscopes that have a common terminal at *GROUND POTENTIAL* (in accordance with OSHA requirements and the National Electric Code.) Exposed metallic surfaces of the probe and the oscilloscope *MUST BE GROUNDED*. Failure to ground the common terminal during certain applications, such as those requiring the oscilloscope to be powered from an external battery, might expose the operator to an electrical shock hazard that could be lethal (depending on voltage and current conditions.)

---

**To clean the probe**

If this probe requires cleaning, disconnect it from all power sources and clean with soft cloth dampened with a mild soap and water solution. Make sure the probe is completely dry before reconnecting it to a power source.

**To connect oscilloscope probes**

---

**To connect oscilloscope probes**

- 1 Attach the probe connector to the desired oscilloscope channel or external trigger input. Push it straight on until it latches into place.

The Agilent 1160 series probes are not compatible with the Aux Trig In or Aux Out connectors on the Infiniium oscilloscope. Use standard BNC cables on these connectors.

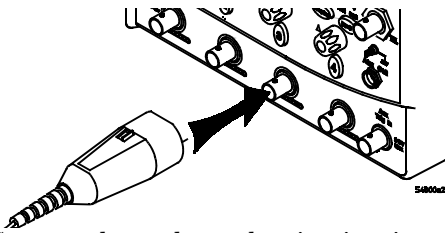

- 2 Connect the probe to the circuit using any of the probing aids.

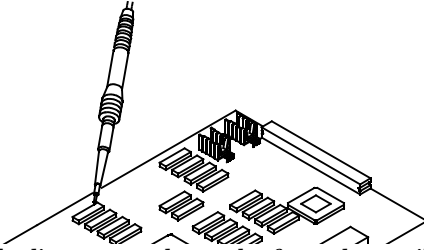

- 3 To disconnect the probe from the oscilloscope, push the small latch on top of the probe connector to the left, then pull the connector body away from the front panel of the oscilloscope without twisting the probe connector.

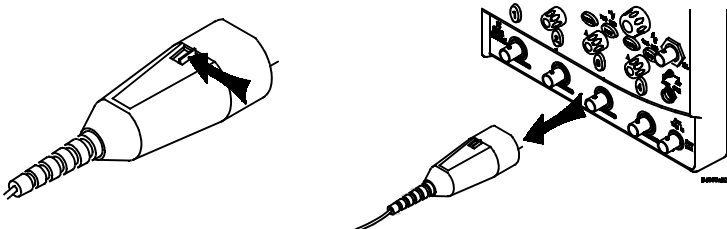

---

**CAUTION**

Do not attempt to twist the snap-on probes on or off the oscilloscope's BNC connector. Twisting with excessive force will damage the probe.

---

## To operate the probe

**CAUTION** Do not solder probe tip to any surface. Solder will damage the probe tip.

**CAUTION** If using the probe without any accessories, the probe could cause a short if dropped within the circuit.

### To attach the probe to the circuit under test

The probe tip may be used without any accessories for probing in hard- to-get places.

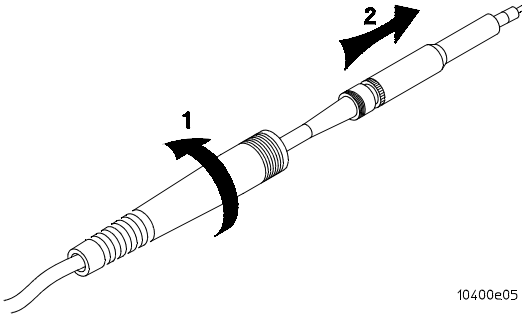

10400e05

The cable strain relief may be unscrewed from the probe and slid back on the cable when using two or more probes in close proximity. When using the probe without the browser or retractable hook tip, the barrel insulator (supplied accessory) should be used to cover the tip ground shield to prevent the hazard of shorting when probing the circuit. The barrel insulator, may be unscrewed and removed to accommodate tight probing situations.

The barrel insulator can be screwed to multiple positions:

- With the barrel insulator screwed all the way on, a spring ground (supplied accessory) may be added to the probe tip to provide ground contact.
- With the barrel insulator screwed most of the way out, the barrel insulator covers the ground shield by the probe tip.

**To operate the probe**

**Probe tip with ground**

Ground the probe by attaching either the alligator ground or spring ground. These ground accessories provide reference for a ground point. To avoid possible shorting of other circuitry, use the barrel insulator in conjunction with any of the grounding accessories.

**Probe tip with browser**

The browser tip has a crown point that digs into solder and won't slip. Attach a ground lead to the probe, then the barrel insulator, and then the browser. The spring-loaded pogo pin allows hand movement without losing contact.

**Probe tip with general purpose retractable hook tip**

The retractable hook tip is used for most typical in-circuit probing and ICs. Attach a ground lead to the probe, then the barrel insulator, and then the retractable hook tip. Attach the hook tip to a probing point by pressing the retractable hook tip body towards the probe body, placing the hook tip around the probing point, and then release the retractable hook tip body.

### The Agilent Wedge Probe Adapter

The Agilent Wedge Probe Adapter makes contact with legs of the IC under test when the Agilent Wedge Probe Adapter conductors are inserted into the space between the legs of the IC. If you are using the Agilent Wedge Probe Adapter, refer to the Agilent Wedge Probe Adapter User's Guide.

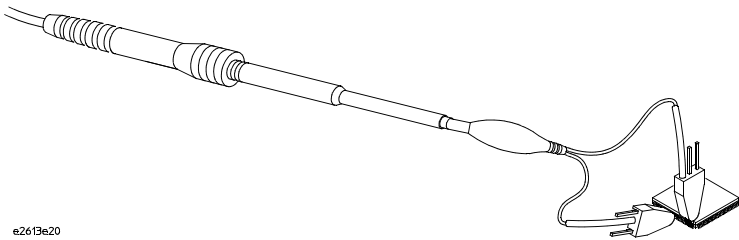

e2613e20

### Connecting the Probe to an Agilent Wedge Adapter

---

#### Agilent Wedge Probe Adapters

---

Agilent Model Number	Description
E2613A	One 0.5 mm x 3-signal wedge
E2613B	Two 0.5 mm x 3-signal wedge
E2614A	One 0.5 mm x 8-signal wedge
E2615A	One 0.65 mm x 3-signal wedge
E2615B	Two 0.65 mm x 3-signal wedge
E2616A	One 0.65 mm x 8-signal wedge
E2643A*	One 0.5 mm x 16-signal wedge
E2644A*	One 0.65 mm x 16-signal wedge

\* 16-signal Agilent Wedge Probe Adapters include 3 removable jumpers  
(Agilent part number 1258-0141 for quantity of 1 jumper)

## Compensation adjustments

The probes can be adjusted for low-frequency compensation and for high-frequency compensation. Low-frequency compensation is an operating adjustment.

Low-frequency compensation is adjusted when the probe is first connected to the oscilloscope. Probe compensation will usually hold over all the attenuator ranges when used with the recommended Agilent Technologies oscilloscope. If the input capacitance of the oscilloscope changes as ranges are switched, compensation must be adjusted each time a new range is selected.

### Low-frequency compensation

Before you can have a flat frequency response when using a compensated passive divider probe, the probe's cable capacitance and scope input capacitance must be compensated to optimize the step response for flatness. You should compensate your probe to match its characteristics to the oscilloscope. A poorly compensated probe can introduce measurement errors. To compensate a probe, follow these steps.

- 1 Connect the probe from the appropriate oscilloscope channel to the front-panel probe adjust signal terminal [  ] on the oscilloscope. The probe can be attached with the holes in the probe body facing up to allow adjustment.
- 2 Press Autoscale.
- 3 Using the wide end of the supplied screwdriver tool, set the low frequency compensation adjustment on the probe for the flattest pulse possible (see figures below.)

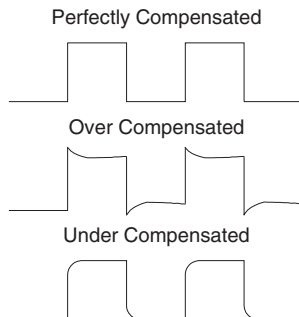
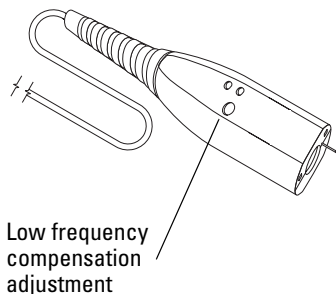

### High-frequency compensation.

High-frequency compensation is not required if you are using the probe that is recommended for your oscilloscope.

The low-frequency compensation procedure must be performed before performing this procedure.

---

### Equipment required

---

Equipment	Specification	Agilent Part Number
50Ω feedthrough	50Ω, BNC(m) and (f)	0960-0301
Adapter	BNC-to-probe tip	5063-2143

- 1 Connect a 50Ω feedthrough to Infiniium oscilloscope Aux Out connector.
- 2 Connect BNC-to-probe tip adapter to 50Ω feedthrough.
- 3 Remove any probing aid and the barrel insulator from the probe tip.
- 4 Connect the probe tip to the BNC-to-probe tip adapter.
- 5 Connect the probe BNC to oscilloscope channel 1. The probe can be attached with the holes in the probe body facing up to allow adjustment.
- 6 Set the Infiniium oscilloscope Aux Out to Probe Comp (set under Utilities...Calibration...Aux Output on the Infiniium oscilloscope.)
- 7 Press Autoscale, then set the time base to 5 ns/div.
- 8 Set sample mode to equivalent time, # of averages to 4 (set under Setup...Acquisition... on the Infiniium oscilloscope.)
- 9 Using the narrow end of the supplied screwdriver tool, rotate high-frequency compensation resistors R1 and R2 fully clockwise.

Agilent 1160 Series Miniature Passive Oscilloscope Probes  
**Compensation adjustments**

- 10** Adjust R1 and R2 alternately in small increments until the displayed waveform has the flattest top.

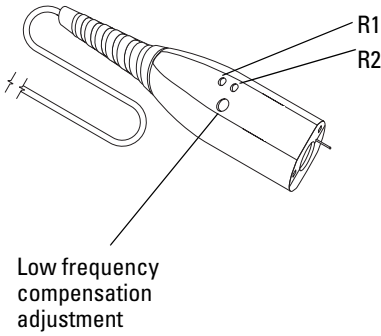

**Test Equipment  
Depot**  
1-800-517-8431

99 Washington Street  
Melrose, MA 02176  
Phone 781-665-1400  
Toll Free 1-800-517-8431

[Visit us at www.TestEquipmentDepot.com](http://www.TestEquipmentDepot.com)

[Back to the Agilent 1160A Product Info Page](#)

# Safety Notices

This apparatus has been designed and tested in accordance with IEC Publication 1010, Safety Requirements for Measuring Apparatus, and has been supplied in a safe condition. This is a Safety Class I instrument (provided with terminal for protective earthing). Before applying power, verify that the correct safety precautions are taken (see the following warnings). In addition, note the external markings on the instrument that are described under "Safety Symbols."

## Warnings

- Before turning on the instrument, you must connect the protective earth terminal of the instrument to the protective conductor of the (mains) power cord. The mains plug shall only be inserted in a socket outlet provided with a protective earth contact. You must not negate the protective action by using an extension cord (power cable) without a protective conductor (grounding). Grounding one conductor of a two-conductor outlet is not sufficient protection.
- Only fuses with the required rated current, voltage, and specified type (normal blow, time delay, etc.) should be used. Do not use repaired fuses or short-circuited fuseholders. To do so could cause a shock or fire hazard.

- If you energize this instrument by an auto transformer (for voltage reduction or mains isolation), the common terminal must be connected to the earth terminal of the power source.

- Whenever it is likely that the ground protection is impaired, you must make the instrument inoperative and secure it against any unintended operation.

- Service instructions are for trained service personnel. To avoid dangerous electric shock, do not perform any service unless qualified to do so. Do not attempt internal service or adjustment unless another person, capable of rendering first aid and resuscitation, is present.

- Do not install substitute parts or perform any unauthorized modification to the instrument.

- Capacitors inside the instrument may retain a charge even if the instrument is disconnected from its source of supply.

- Do not operate the instrument in the presence of flammable gasses or fumes. Operation of any electrical instrument in such an environment constitutes a definite safety hazard.

- Do not use the instrument in a manner not specified by the manufacturer.

## To clean the instrument

If the instrument requires cleaning: (1) Remove power from the instrument. (2) Clean the external surfaces of the instrument with a soft

cloth dampened with a mixture of mild detergent and water. (3) Make sure that the instrument is completely dry before reconnecting it to a power source.

## Safety Symbols



Instruction manual symbol: the product is marked with this symbol when it is necessary for you to refer to the instruction manual in order to protect against damage to the product.



Hazardous voltage symbol.



Earth terminal symbol: Used to indicate a circuit common connected to grounded chassis.

# Notices

© Agilent Technologies, Inc. 1997-2006

No part of this manual may be reproduced in any form or by any means (including electronic storage and retrieval or translation into a foreign language) without prior agreement and written consent from Agilent Technologies, Inc. as governed by United States and international copyright laws.

## Manual Part Number

01160-92009, Nov. 2006

## Print History

01160-92009, Nov. 2006  
01160-92008, Sept. 2006  
01160-92007, June 2005  
01160-92006, March 2003  
01160-92005, March 2002  
01160-92004, Nov. 2001  
01160-92003, Nov. 1999  
01160-92002, Oct. 1998  
01160-92001, May 1998  
01160-92000, June 1997

## Restricted Rights Legend

If software is for use in the performance of a U.S. Government prime contract or subcontract, Software is delivered and licensed as "Commercial computer software" as defined in DFAR 252.227-7014 (June 1995), or as a "commercial item" as defined in FAR 2.101(a) or as "Restricted computer software" as defined in FAR 52.227-19 (June 1987) or any equivalent agency regulation or contract clause. Use, duplication or disclosure of Software is subject to Agilent Technologies' standard commercial license terms, and non-DOD Departments and Agencies of the U.S. Government will receive no greater than Restricted

Rights as defined in FAR 52.227-19(c)(1-2) (June 1987). U.S. Government users will receive no greater than Limited Rights as defined in FAR 52.227-14 (June 1987) or DFAR 252.227-7015 (b)(2) (November 1995), as applicable in any technical data.

## Document Warranty

**The material contained in this document is provided "as is," and is subject to being changed, without notice, in future editions. Further, to the maximum extent permitted by applicable law, Agilent disclaims all warranties, either express or implied, with regard to this manual and any information contained herein, including but not limited to the implied warranties of merchantability and fitness for a particular purpose. Agilent shall not be liable for errors or for incidental or consequential damages in connection with the furnishing, use, or performance of this document or of any information contained herein. Should Agilent and the user have a separate written agreement with warranty terms covering the material in this document that conflict with these terms, the warranty terms in the separate agreement shall control.**

## Technology Licenses

The hardware and/or software described in this document are furnished under a license and may be used or copied only in accordance with the terms of such license.

## Trademark Acknowledgements

Windows and MS Windows are U.S. registered trademarks of Microsoft Corporation.

## WARNING

**A WARNING notice denotes a hazard. It calls attention to an operating procedure, practice, or the like that, if not correctly performed or adhered to, could result in personal injury or death. Do not proceed beyond a WARNING notice until the indicated conditions are fully understood and met.**

## CAUTION

**A CAUTION notice denotes a hazard. It calls attention to an operating procedure, practice, or the like that, if not correctly performed or adhered to, could result in damage to the product or loss of important data. Do not proceed beyond a CAUTION notice until the indicated conditions are fully understood and met.**