

Pomona®

Model 6087  
Field Service Kit, Red, ESD

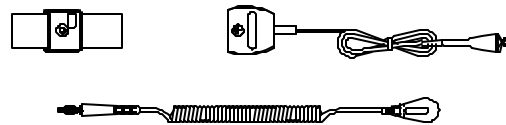
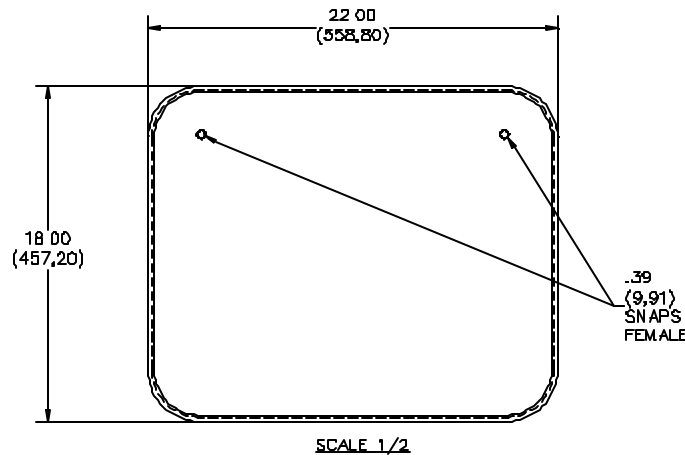

**FEATURES:**

- Complete and durable service kit for static sensitive work.
- Features is a static-safe 460 x 560 mm (18" x 22") laminated red vinyl mat.
- Kit includes a mat with two 10mm snap sockets, common point ground connector with two Banana Plug Jacks and a 15' ground lead, an adjustable elastic wrist strap (Model 6081) and a resistive coil cord (Model 5534)
- Folds down to fit into your tool kit

**MATERIALS:**

**Anti-Static Ground Cord**

Body: Plug – Brass, nickel plate, fits 4,2 (.17) standard Banana Jack

Insulation: Banana Plug – Thermoplastic elastomer, Black

Cord: Coiled Tinsel Cord, vinyl jacket, 2,5 (.10) O.D.

Body: Snap – Brass, nickel plate, fits 4,0 (.16) snap stud

Insulation: Snap – Thermoplastic elastomer, Black

**Wrist Strap**

Body: Impact resistant plastic, Blue

Strap: Elastic fibers with silver plated Nylon, Yarn, Circumference: 64,0 (2.50) min., 330,0 (13.00) Max.

Snap and Cam: Stainless Steel, 4,0 (.16) snap stud

All dimensions are in inches. Tolerances (except noted): .xx = ±.02" (.51 mm), .xxx = ± .005" (.127 mm).

All specifications are to the latest revisions. Specifications are subject to change without notice.

Registered trademarks are the property of their respective companies. Made in USA

MAT, ESD: 0,46 (.018") thick, vinyl, Red

Common Point Ground Cord

Snap W/BananaJacks End:

Body: Snap – Brass, Nickel Plate. 10,0 (.39), Male

Resistor: One Megohm resistor, insulated

Insulation: Snap – Thermoplastic elastomer, Black

Cord: 22 AWG, vinyl jacket, 2,5 (.10) O.D., Length: 46,0 (17.0)

Banana Jacks: Brass, Nickel plated. Fits 4,2 (.17) STD B-Plug

Insulation: PVC, Black

## RATINGS:

Surface Resistivity: 108 to 109 Ohm/Sq.

Volume Resistivity: 109 Ohm cm

Static Decay: 0.01 sec 5000V to 0V 12% RH

## ORDERING INFORMATION: Model 6087

Packaging: One Anti-Static ground cord, common point ground cord, Mat, Wrist strap, and two instruction sheets, per bag

All dimensions are in inches. Tolerances (except noted): .xx = ±.02" (.51 mm), .xxx = ±.005" (.127 mm).

All specifications are to the latest revisions. Specifications are subject to change without notice.

Registered trademarks are the property of their respective companies. Made in USA

6/9/99

SY/EH/LS

C:\Laura Goldberg\FlukeDataSheet\6087\_1\_01.doc

P

M