

Pomona®

Model 5319
Adapter – BNC Female To Phono Plug

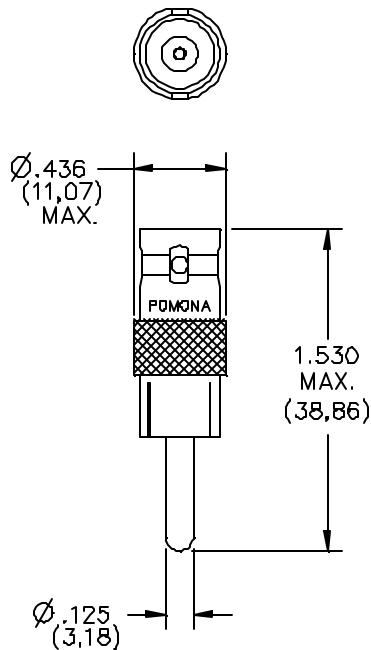

FEATURES:

- Permits BNC male to be used with equipment having phono jacks.
- Similar to model 2957, except for length and contact plating.

MATERIALS:

Body and Center Contact: Brass per QQ-B-626, Alloy, 360, ½ Hard.

Dielectric: Delrin

Finish: Body and Contacts: Nickel plated.

Marking: “POMONA 5319” located approximately as shown.

RATINGS:

Operating Temperature: +102°C. (216°F.) Max.

Operating Voltage: 500 VRMS Max.

ORDERING INFORMATION: Model 5319

All dimensions are in inches. Tolerances (except noted): .xx = ±.02” (.51 mm), .xxx = ± .005” (.127 mm).
All specifications are to the latest revisions. Specifications are subject to change without notice.
Registered trademarks are the property of their respective companies. Made in USA

6/9/99 0

SY/EHLS .

C:\Laura Goldberg\FlukeDataSheet\d5319_1_01.doc