

Model 2901 Size C Aluminum Box With Cover

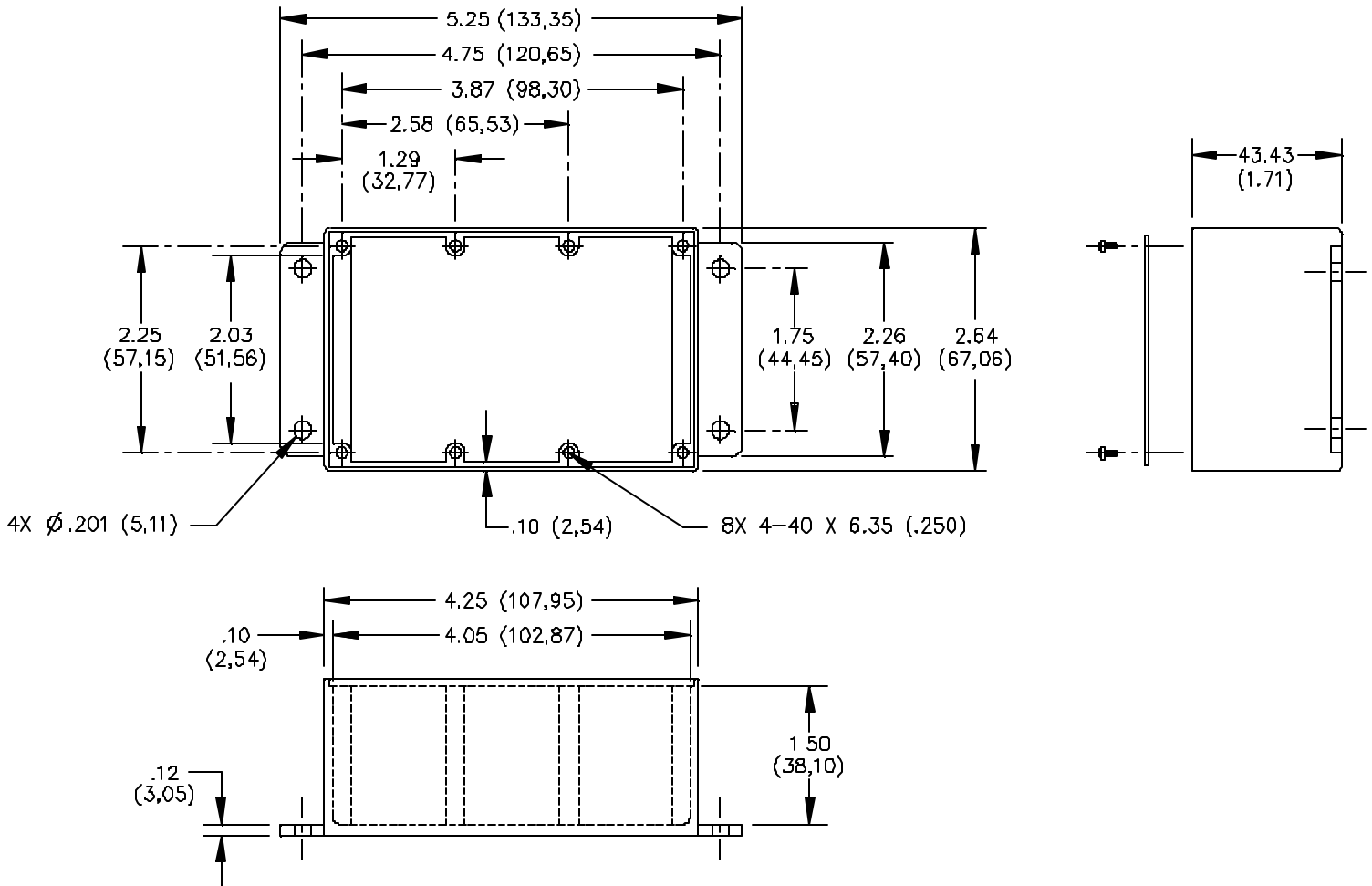

MATERIALS:

Screws: (8) 4-40 x 6.35 (.25) Phillips, Pan Head – Steel

Finish: Zinc Plated

Cover: 2.03 (.080) Thick aluminum, Alloy 1100-H14

Finish: Clear anodized per MIL-A-8625.

Shielded Housing: Die cast aluminum, Alloy A380 or A384.

Finish: Blue paint per Federal Standard 595, Color No. 25109.

ORDERING INFORMATION: Model 2901

All dimensions are in inches. Tolerances (except noted): .xx = ±.02" (.51 mm), .xxx = ±.005" (.127 mm).

All specifications are to the latest revisions. Specifications are subject to change without notice.

Registered trademarks are the property of their respective companies. Made in USA