

**Models 1581, 2854 & 4900
Panel Mount Banana Jack**

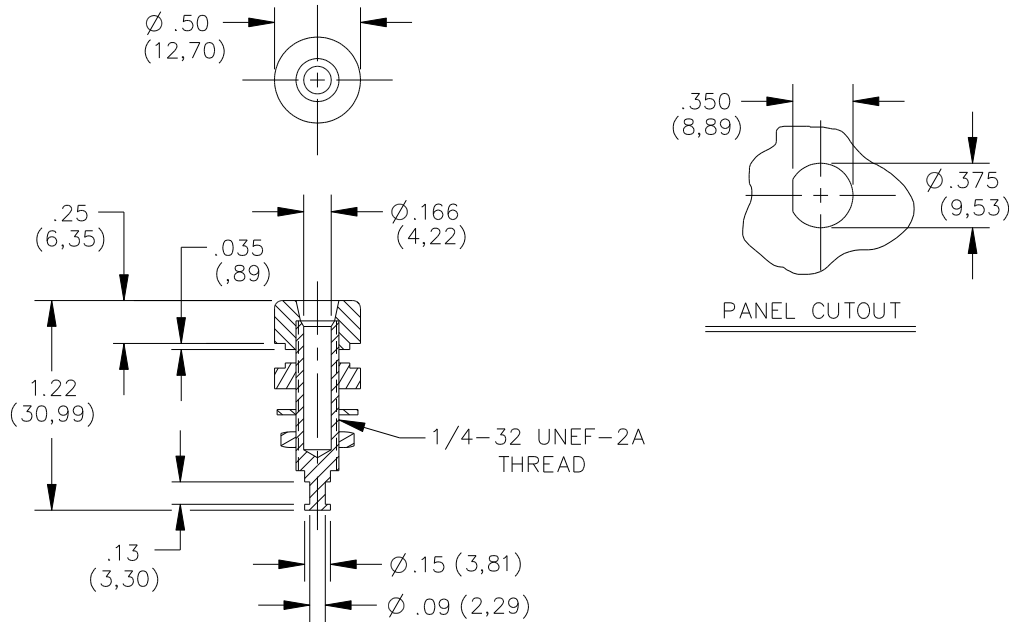

FEATURES:

- Banana Jacks mount into panels ranging in thickness from .063" (1.6mm) to .375" (9.5mm).
- Model 4900 features Polypenylene Sulfide for high temperature applications.
- Model 2854 features gold plated body for optimum electrical connection.
- Model 1581 features bright tin plating

MATERIALS:

Banana Jack: Body – Brass Nickel Plated, (Model 2854, Brass, Gold Plated)
 Insulators: Polycarbonate (Model 4900, High Temperature Polyphenylene Sulfide)
 1/4 Internal Locking Washer: Steel, Nickel Plated
 1/4-32 Hex Nut: Brass, Nickel Plated

RATINGS:

Operating Voltage: Hand-held Testing: 30VAC/60VDC Max.
 Hand Free Testing in controlled Voltage Environment: 2500 WVDC.
 Operating Temperature: +115°C (+239°F), Model 4900 +220°C (+428°F)
 Current: 15 Amperes

ORDERING INFORMATION: Model #-Color Code

1581 Std. Colors: -0 Black, -1 Brown, -2 Red, -3 Orange, -4 Yellow, -5 Green, -6 Blue, -7 Violet, -8 Gray, -9 White
 2854 Std. Colors: -0 Black, -1 Brown, -2 Red, -4 Yellow, -5 Green, -6 Blue, -8 Gray, -9 White (Other colors available contact Pomona Technical Support: 800-241-2060 (technicalsupport@pomonatest.com))
 4900 Std. Colors: -0 Black, -6 Blue.

Sold unassembled, in packages of 10 per color
 Ordering Example: 2854-2 Gold Plated Banana Jack, Color: Red

All dimensions are in inches. Tolerances (except noted): .xx = ±.02" (.51 mm), .xxx = ±.005" (.127 mm).
 All specifications are to the latest revisions. Specifications are subject to change without notice.
 Registered trademarks are the property of their respective companies. Made in USA