

Clamp-On Ground Resistance Testers Models 3711 & 3731



The Models 3711 and 3731 measure ground rod and grid resistance in any environment without the use of auxiliary ground rods. Clamp-on ground resistance testers are used on multi-grounded systems without disconnecting the ground under test. The Models 3711 and 3731 simply clamp around the ground conductor or rod and measure the resistance to ground fast and accurately.

By performing measurements on installed ground systems, the user also verifies the quality of the

grounding connections and bonds. Resistance and continuity of grounding loops around pads and buildings may also be measured.

Both models include a current measurement function. The probe's high sensitivity enables measurement of leakage current flowing to ground or circulating in ground loops down to 1mA and neutral and phase currents to 30Arms. This feature provides additional information, which is vital in distribution ground networks carrying higher levels of noise and harmonics, that affect power quality.

The Model 3731 offers an alarm function and a memory (logging) function. In the alarm mode, the probe will audibly and visually indicate readings beyond set point. The user may also have the alarm initiated above or below the set point. This alarm feature permits quick field checks where only "pass" or "fail" readings will suffice.

Features

- Simple and fast clamp-on operation – no leads, no auxiliary rods or spacing requirements
- Direct reading of ground resistance from 0.01Ω to 1200Ω
- Direct reading of continuity and ground loop resistance
- Direct reading of ground leakage or phase current from 1mA to 30Arms
- Jaw design with large 1.25" (32mm) window – accommodates up to 1000kcmil cables
- Auto-Off for power management
- Alarm function with adjustable set point and buzzer for quick field checks (Model 3731)
- Memory function to store 99 field measurements for later retrieval and analysis (Model 3731)
- Meets EN 61010, Cat. III
- CE Mark and UL approved
- Rugged Lexan® head and body construction resists breakage
- Alarm settings and stored memory information saved during shutdown (Model 3731)
- Patented design

Applications

- Measure electrical ground rod and grid resistance
- Use on multi-grounded systems without disconnecting the ground rod under test
- Measure resistance and continuity of grounding loops around pads and buildings
- Measure leakage current flowing to ground or circulating in ground systems
- Conduct field surveys and retrieve and analyze readings at a later time
- Use on cell towers and telecommunication sites
- Use on pools, spas and other consumer installations



Model 3731 performing a ground rod resistance check.

FUNCTIONS & FEATURES

	3711	3731
Ohms Range	✓	✓
Arms Range	✓	✓
Hold Function	✓	✓
Self Test	✓	✓
Auto-Off	✓	✓
Battery Life Indicator	✓	✓
Noise Indicator	✓	✓
Open Jaw Indicator	✓	✓
Closed Loop Indicator	✓	✓
Multi-Tone Beeper	✓	✓
Alarm Function	—	✓
Memory (Logging)	—	✓

Specifications

MODELS	3711 & 3731		
ELECTRICAL			
Ground Resistance Ranges Auto-Ranging 0.1 to 1200Ω	Measurement Range	Resolution	Accuracy (% of Reading)
	0.10 to 1.00Ω	0.01Ω	±(2% ± 0.02Ω)
	1.0 to 50.0Ω	0.1Ω	±(1.5% ± 0.1Ω)
	50.0 to 100.0Ω	0.5Ω	±(2% ± 0.5Ω)
	100 to 200Ω	1Ω	±(3% ± 1Ω)
	200 to 400Ω	5Ω	±(6% ± 5Ω)
	400 to 600Ω	10Ω	±(10% ± 10Ω)
600 to 200Ω	50Ω	Not Rated	
Current Measurement Ranges Auto-Ranging 1mA to 30.00Arms	Measurement Range	Resolution	Accuracy (% of Reading)
	1 to 299mA	1mA	±(2.5% + 2mA)
	0.300A to 2.999A	0.001A	±(2.5% + 2mA)
3.00A to 29.99A	0.01A	±(2.5% + 20mA)	
Resistance Measurement Frequency		2403Hz	
Current Measurement Frequency		47 to 800Hz	
Current Overload		OL displayed above 29.99Arms	
MECHANICAL			
Dimensions	9.25 x 3.94 x 2.17" (235 x 100 x 55mm)		
Weight	2.2 lbs (1kg)		
Jaw Window Diameter	1.25" (32mm)		
Jaw Opening	1.38" (35mm)		
Operating Temperature	14° to 131°F (-10° to 55°C)		
Operating Humidity	10 to 90% RH @ 14° to 104°F (-10° to 40°C), 75% RH @ 131°F (55°C)		
Storage Temperature	-22° to 158°F (-30° to 70°C)		
LCD	3¼ Digit, 1.73 x 1.10" (44 x 28mm)		
Power Source	9V Alkaline battery (IEC 6LF22 or NEDA 1604A)		
Battery Life	Typical: 8 hours or approx. 1000 measurements of 30 seconds		
U.S. Patent	No. 362,639		
UL File No.	E192383		
SAFETY			
Safety Rating	EN 61010-2-032 (Class 2) Double Insulation		
CE Mark	Yes		

Construction

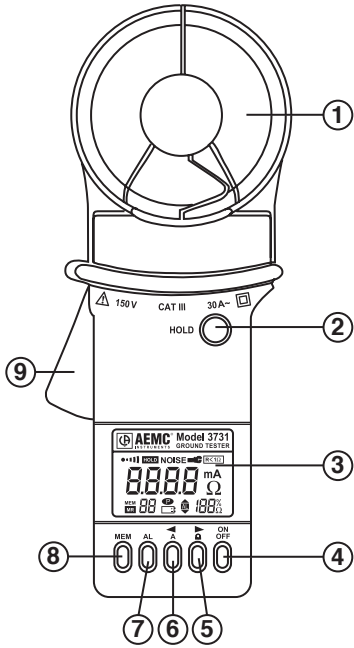

1. Head Assembly: Consists of two individually shielded magnetic cores
2. Hold: Freezes last measured value on the display
3. Display: 3000-count LCD, function indicators
4. ON/OFF: Power ON or OFF, activates display self test at power-up
5. Ω: Resistance Measurement – Increment the Alarm setpoint, increment Memory position in program mode
6. A: Current Measurement – Decrement the Alarm setpoint, decrement the Memory in program mode
7. AL: Activates/deactivates the Alarm function, access the value of the Alarm setpoint in program mode (Model 3731)
8. MEM: Stores the reading into memory, reads memory Recall (MR) values and clears the memory in recall mode (Model 3731)
9. Lever: Opens or closes jaws

The Models 3711 and 3731 bodies are built of Lexan® (or equivalent polycarbonate) for rugged use. The probe heads are encapsulated in a double-walled shell for extra strength and reinforced for enhanced field reliability. Overall construction and mechanical design ratings such as drop test, shock, vibration and weather-proofing against water penetration or dust, meet or exceed IEC standards. These products have also been designed to EN 61010, Cat. III and are UL approved. Both models are CE Marked.

The probe head, (jaw) is a key component in the measurement and overall product performance. The large jaw thickness permits use on tight ground conductors on poles and in manholes. The 1.25" (32mm) opening accommodates not only ground rods, but also larger ground conductors (up to 1000kcmil) typically found in telecommunication buildings or railroad applications.

The inner jaw is composed of two independent and individually shielded magnetic cores, permitting measurement without noise interference or cross talk common to instruments with separate probes.

Thorough mechanical design, including small winglets, ensures reliable and repetitive jaw alignment for accuracy and prevents undesirable contaminations into the jaw spring assembly.

CE requirements and design minimize electromagnetic interference near substations and tower sites.

The ergonomic body design permits one-handed operation. The guard provides additional strength, and prevents the hand from slipping or coming into contact with conductors under test. The LCD lens cover may be easily replaced if scratched. The sealed push-buttons directly access all test functions and are easily operated even with gloved hands.

OVERVIEW OF FUNCTIONS

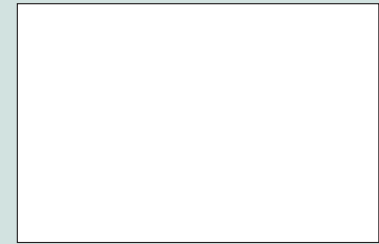

- Ω** Displayed when measuring resistance
- mA, A** Displayed when measuring current
- 100%** Percentage of battery life remaining
- Flashing indicates low battery condition
- Indicates the Auto-Off feature is inactive
- Indicates Alarm Active Hi or Lo depending on which arrow is displayed
- HOLD** HOLD pushbutton has been pressed
- Active beeper function
- NOISE** Noise in the reading
- Probe jaws not closed properly
- Alarm set points
- MEM** Memory function active
- Memory Recall (MR) and location (from 1 to 99)
- Resistance measured is below 1Ω



BUTTONS

- ON/OFF**
Power ON or power OFF. Activates display self test at power-up.
- Ω (▶)**
Resistance measurement. (Adjusts the alarm set point and the memory position when in programming mode.)
- A (◀)**
Current measurement. (Adjusts the alarm set point and the memory position when in programming mode.)
- AL (Model 3731 only)**
Activate/deactivate the alarm function. Access the value of the alarm set point when in programming mode.
- MEM (Model 3731 only)**
Activate the memory function or to read the stored values in MR (Memory Recall). Clears the memory when in programming mode.

Clamp-On Ground Resistance Tester Models 3711 & 3731 include calibration loop, battery and user manual in hard carrying case.



Calibration Check Loop (included)

ORDERING INFORMATION

CATALOG NO.

Ground Resistance Tester Model 3711 (Clamp-On)	Cat. #2117.60
Includes hard carrying case, 9V Alkaline battery, 25Ω calibration check loop and user manual	
Ground Resistance Tester Model 3731 (Clamp-On) with memory and alarm	Cat. #2117.61
Includes hard carrying case, 9V Alkaline battery, 25Ω calibration check loop and user manual	

